

PRODUCT INFORMATION
CANNED MOTOR PUMP TYPE LC

RAILWAY / ENERGY



ZART®

simply best balance

Table of Contents

General information	3	Technical data	10
Standard	4	Documentation and tests	11
How the LC pump works	4	Collective measurements	12
Operating principle	5	LC32-160 cable	13
Bearings	5	Modular	14
Characteristic maps	6	Options	14
2950 rpm 50 Hz	6	Individual adaptations	15
3500 rpm 60 Hz	7	Contact	16
Benefits	8		



Table of Contents

General information
Standard
Operating principle
Characteristic maps
Benefits
Technical data
Documentation and tests
Collective measurements
Modular
Individual adaptations
Contact

Information

Applications

To cool inverters in applications such as transport and wind turbines demanding long service life and weight benefits.

Most frequently used pumped medium

A water-glycol mixture is used as the pumped medium in most cases. However, it is also possible to use alternative non-explosive media.

Directives

The LC series has been designed according to Standard CLC/TS 50537-3 for railway applications. This is also reflected in optimum corrosion protection and highest fire protection according to EN 45545-2.

Type / design

Horizontal, volute casing pumps without shaft seal in process design with fully enclosed, single-stage and single-flow canned motor. The connection dimensions of the housing correspond to SAE 2" according to ISO 6162-1.

Drive

The rotor lining – one of our core competencies – is manufactured by impact extrusion and, as a stainless steel alloy, is an essential component of the highly efficient canned motor. The liquid-filled canned motor accelerates to operating speed within seconds and operates wear-free and maintenance-free in continuous operation due to the hydrodynamic plain bearings. The canned motor is low-noise and low-vibration and offers double security against leakage.

Standard:	proven standard products available at short notice
Modular:	flexible modular system with limited choice
Customisation:	individual adaptations according to customer requirements

Operating data

	LC32-125	LC32-160
Pump capacity [Q]:	up to 15.9 m ³ /h up to 266 l/min	up to 19.2 m ³ /h up to 320 l/min
Pumping head [H]:	up to 25 m	up to 38 m
Motor output:	1.8 kW (optional 1.0 kW)	3.0 kW
Nominal pressure:	10 bar	10 bar
Operating temperature [t]:	-40 °C to +80 °C	-40 °C to +80 °C

(extended performance range available on request)

Pump and hydraulics designations

LC 32 – 160 AGX3.0 Harting plug

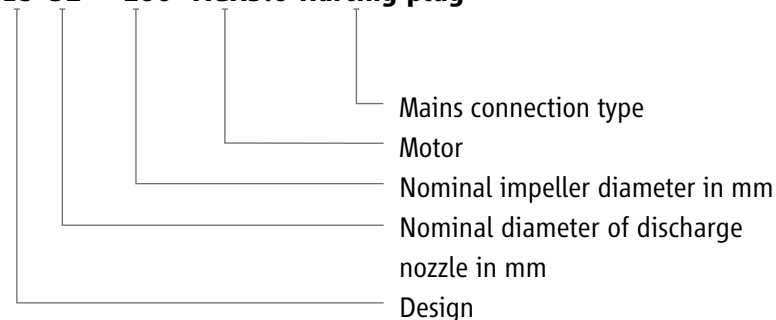

Table of Contents

General information

Standard

Operating principle

Characteristic maps

Benefits

Technical data

Documentation and tests

Collective measurements

Modular

Individual adaptations

Contact



How the LC pump works

To cool the motor and lubricate the plain bearings, part of the flow is branched off at the periphery of the impeller and, after flowing through the motor, returned to the suction side of the impeller through the hollow shaft. This design is suitable for pumping non-critical liquids with low vapour pressure.

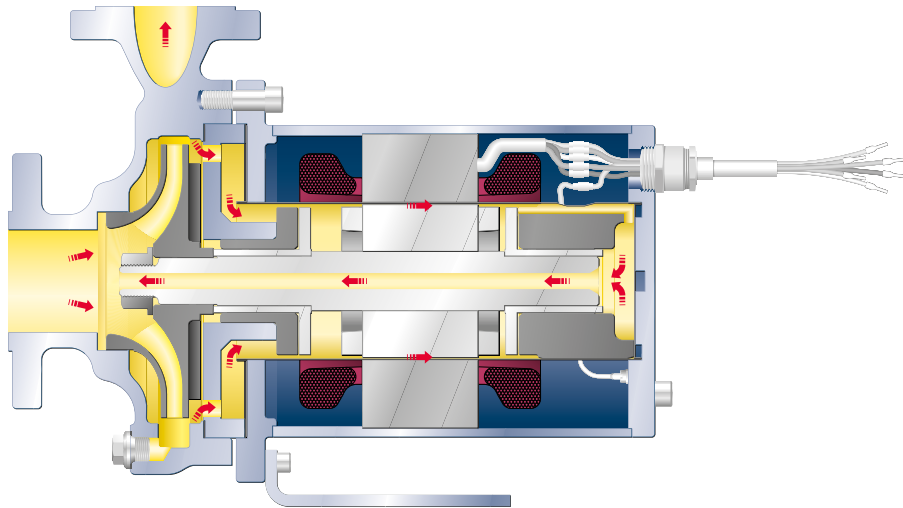

Partial flow return to the suction side

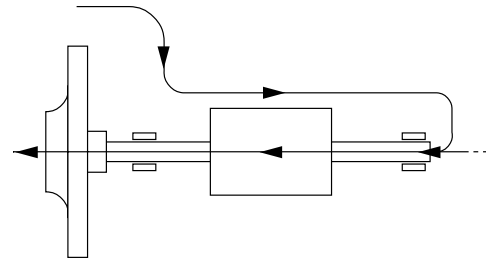

Table of Contents

General information

Standard

Operating principle

Characteristic maps

Benefits

Technical data

Documentation and tests

Collective measurements

Modular

Individual adaptations

Contact



Bearings

The hermetically sealed design requires the arrangement of bearings in the pumped liquid. Therefore, only hydrodynamic plain bearings are used in HERMETIC pumps. With correct operational mode, these bearings have the advantage that there is no contact between the bearing sliding surfaces. As a result, they are wear-free and maintenance-free in continuous operation. A service life of 20 years is common for hermetically sealed pumps.

In refrigeration engineering, carbon graphite is used as the bearing bush material that can withstand particularly high radial and axial loads. In addition, the material has a high resistance to elevated and low temperatures and high fatigue strength.

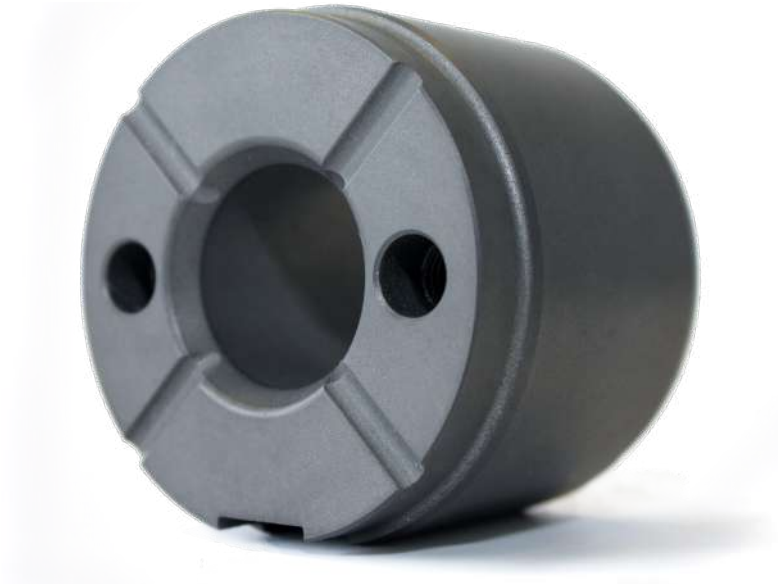

Table of Contents

General information

Standard

Operating principle

Characteristic maps

Benefits

Technical data

Documentation and tests

Collective measurements

Modular

Individual adaptations

Contact



2950 rpm 50 Hz

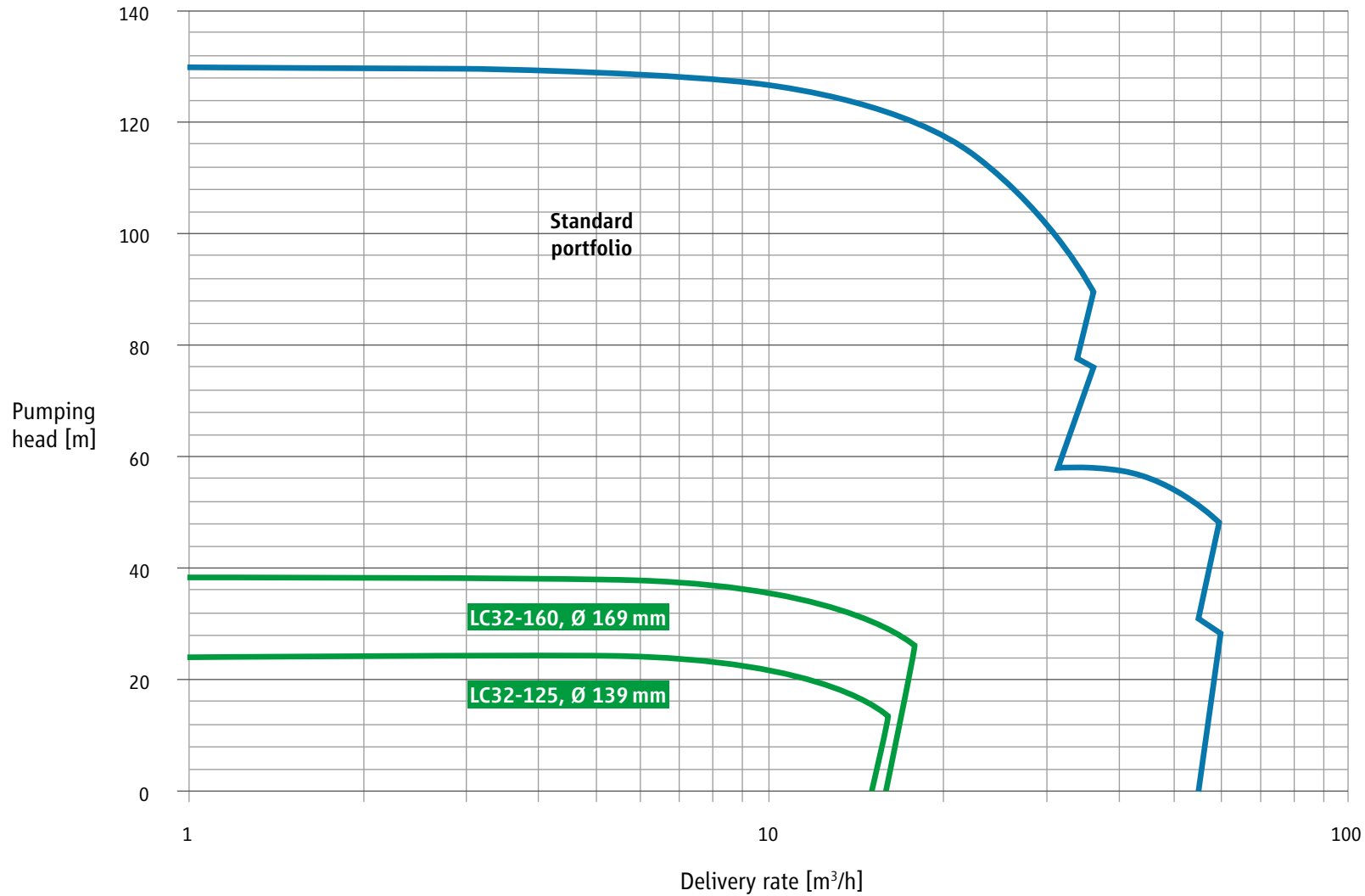

- Table of Contents
- General information
- Standard
- Operating principle
- Characteristic maps**
- Benefits
- Technical data
- Documentation and tests
- Collective measurements
- Modular
- Individual adaptations
- Contact



3500 rpm 60 Hz

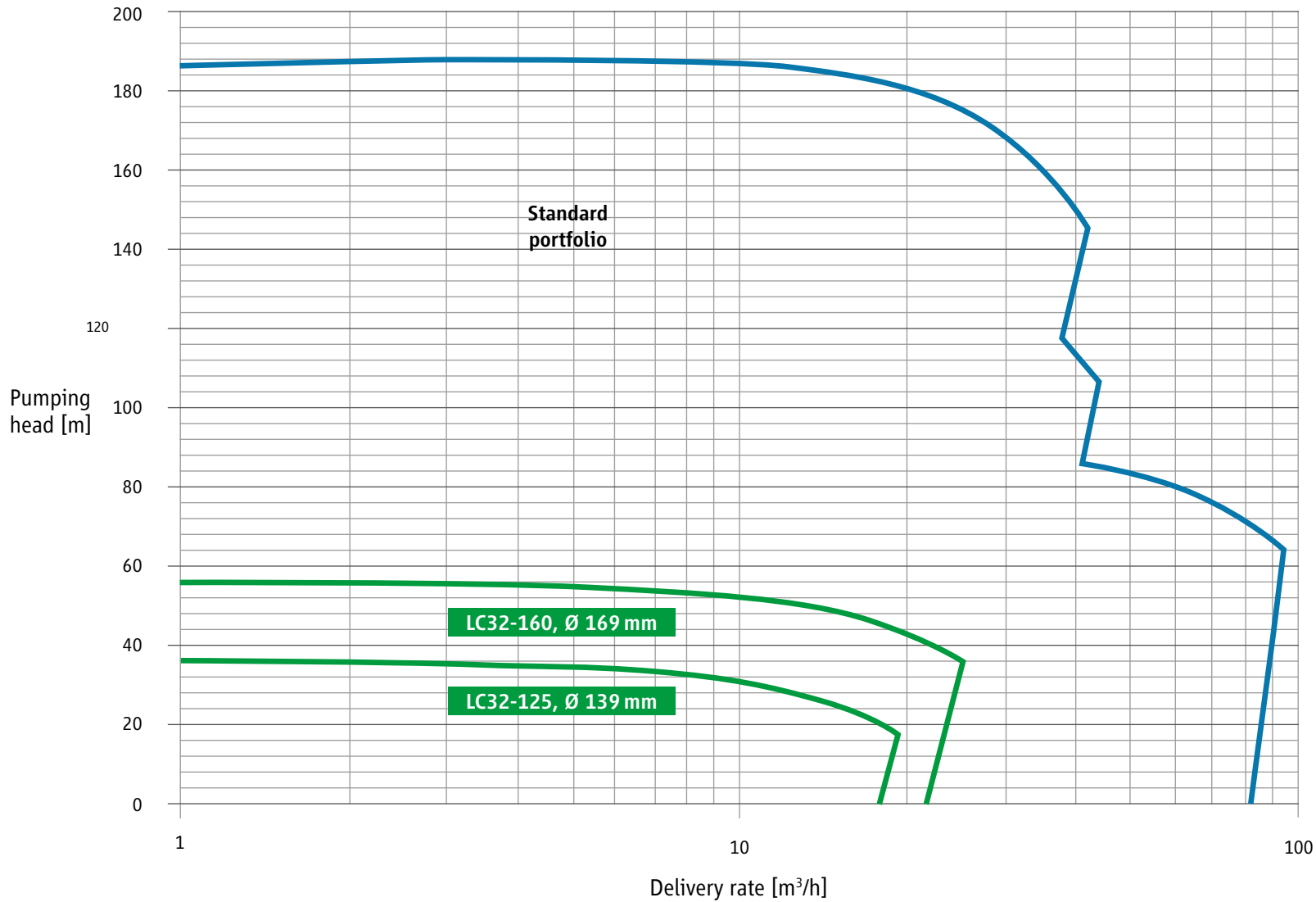

Table of Contents

General information

Standard

Operating principle

Characteristic maps

Benefits

Technical data

Documentation and tests

Collective measurements

Modular

Individual adaptations

Contact



Benefits of the canned motor type LC

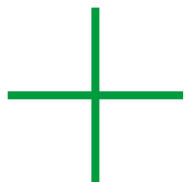

Approximately 20 % weight saving compared to conventional construction

Attractive prices and low life-cycle costs due to long service life

Mean Time Between Failures (MTBF) is more than 130,000 hours

Fast development to meet individual customer requirements

Hermetically sealed system without media loss

ZART® system for longevity of hydrodynamic bearings

Extremely compact

Horizontal and vertical mounting as well as 90° versions

Among other things vibration tests according to EN 61373

Highest corrosion and fire protection

Table of Contents

General information

Standard

Operating principle

Characteristic maps

Benefits

Technical data

Documentation and tests

Collective measurements

Modular

Individual adaptations

Contact



Benefits of the canned motor type LC

Flanges

- SAE 2"
- According to customer request

30 Hz – 70 Hz

Standards:

- CLC TS 50537-3
- EN 45545-2

HERMETIC ZART®

Hydrodynamic bearings FH82A

Base optionally in stainless steel

Connection:

- Cable (RADOX)
- Harting
- Weidmueller

Paintwork:

- Standard 40 µm (inside)
- Paintwork type "A" 120 µm (outside)
- Paintwork type C5 200 µm (extreme conditions)

Table of Contents

General information

Standard

Operating principle

Characteristic maps

Benefits

Technical data

Documentation and tests

Collective measurements

Modular

Individual adaptations

Contact



Technical data

Canned motor data	LC32-125	LC32-160
Nominal pressure	10 bar	10 bar
Operating temperature	-40 °C to +80 °C	-40 °C to +80 °C
Weight	37 kg	42 kg
Impeller diameter	100 mm to 139 mm	100 mm to 169 mm
Noise level (50Hz / 60Hz)	< 61 dB / < 64 dB	< 65 dB / < 68 dB

General characteristics	LC32-125	LC32-160
Output power P2	max. 1.8 kW (optional 1.0 kW)	max. 3.0 kW
Speed	1,450 rpm to 3,500 rpm	1,450 rpm to 3,500 rpm
Operating mode	S1 according to EN 60034-1	S1 according to EN 60034-1
Type of protection (motor)	IP 66	IP 66
Motor protection in winding	PTC thermistor KL180	PTC thermistor KL180

Paintwork	LC32-125	LC32-160
Corrosion protection (paintwork)	up to C5	up to C5
Fire protection (paintwork)	R1 and R7 for HL1, HL2 and HL3	R1 and R7 for HL1, HL2 and HL3
Colour	RAL 7021 (black grey)	RAL 7021 (black grey)
Paint thickness	40 µm to 200 µm (various options)	40 µm to 200 µm (various options)

Table of Contents

General information

Standard

Operating principle

Characteristic maps

Benefits

Technical data

Documentation and tests

Collective measurements

Modular

Individual adaptations

Contact



Documentation and tests

Documentation according to HERMETIC Standard, consisting of:

Operating manual for the HERMETIC pump

Technical specifications

Characteristic curve of the pump

Sectional drawing

Parts list

Dimensional drawing

Cable connection diagram

Plain bearing play

EU Declaration of Conformity

Warranty

30 months from delivery

Standard tests

Hydrostatic pressure test with 1.5x nominal pressure

Balancing of shaft and impeller according to DIN ISO 1940, 6.3

Leak test of the complete pump

Functional test

Additional test

Shock and vibration tests according to EN 61373

Fire protection test according to EN 45545-2

Table of Contents

General information

Standard

Operating principle

Characteristic maps

Benefits

Technical data

Documentation and tests

Collective measurements

Modular

Individual adaptations

Contact



LC32-125 cable

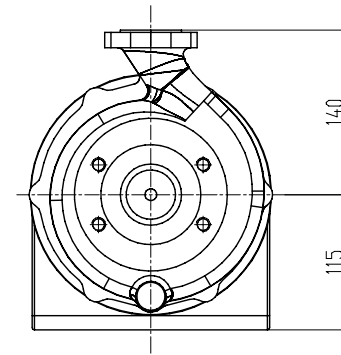
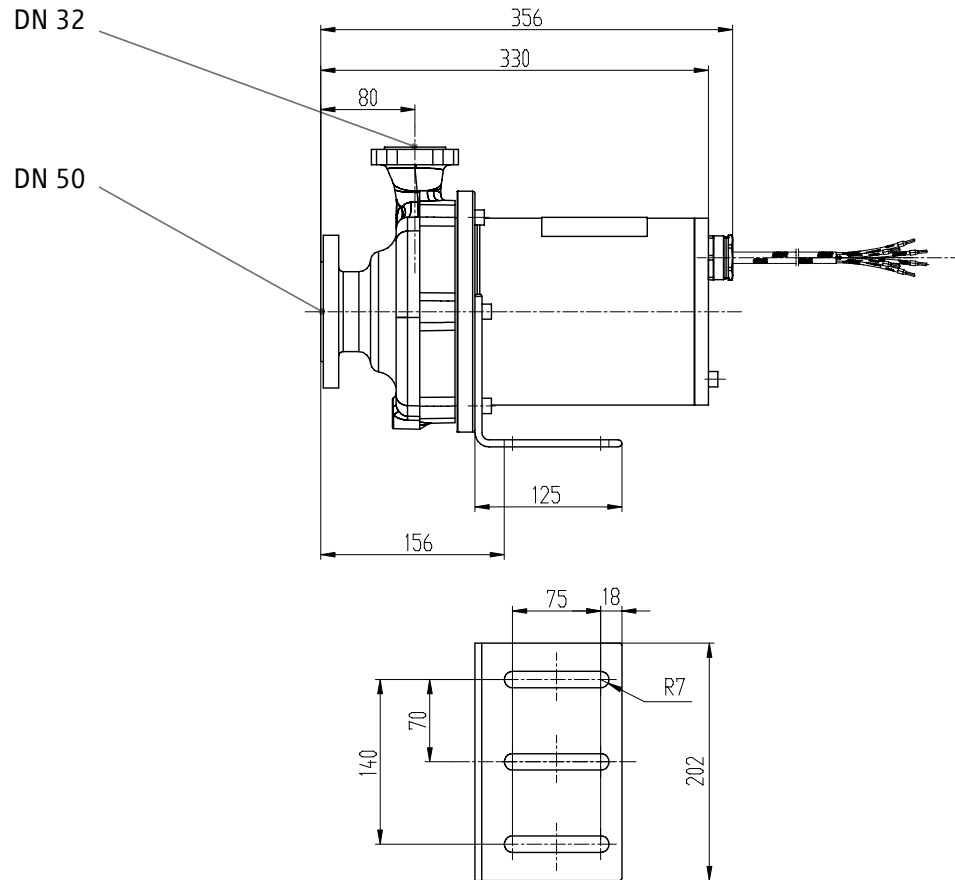

Table of Contents

General information

Standard

Operating principle

Characteristic maps

Benefits

Technical data

Documentation and tests

Collective measurements

Modular

Individual adaptations

Contact



LC32-160 cable

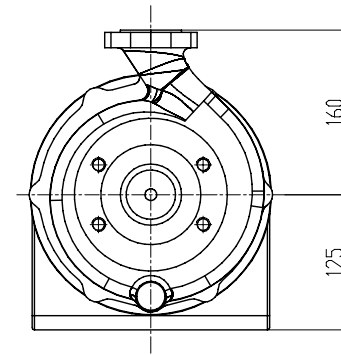
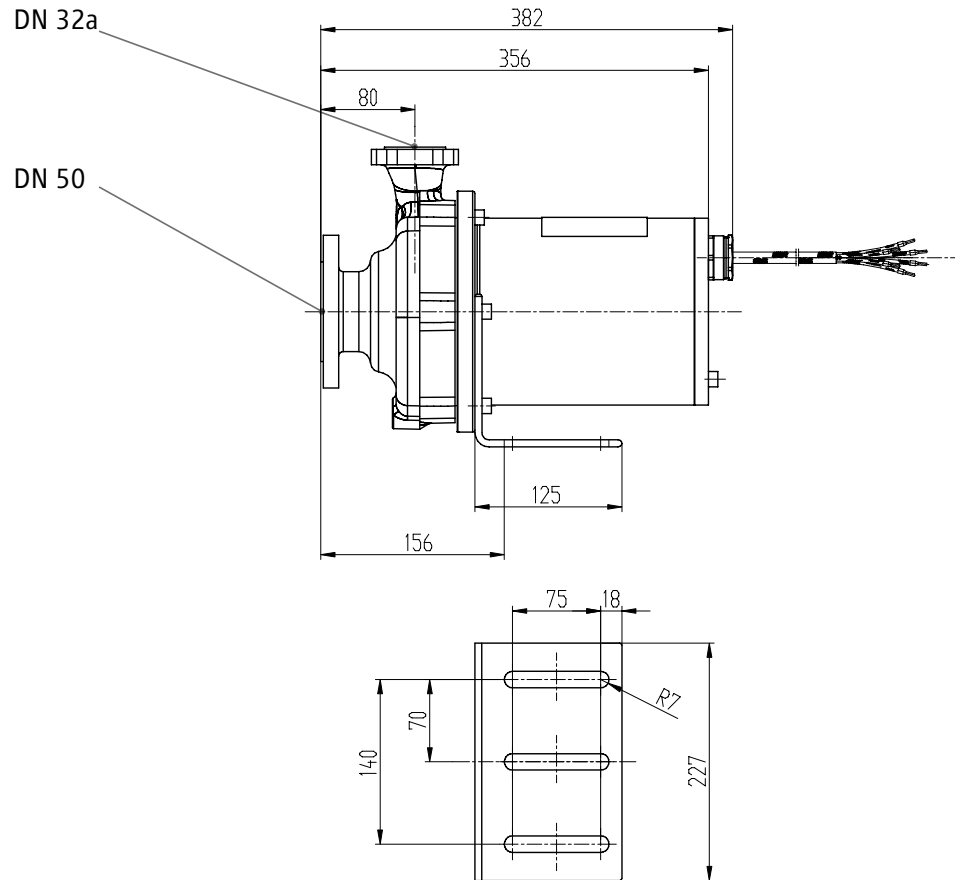

Table of Contents

General information

Standard

Operating principle

Characteristic maps

Benefits

Technical data

Documentation and tests

Collective measurements

Modular

Individual adaptations

Contact



Options

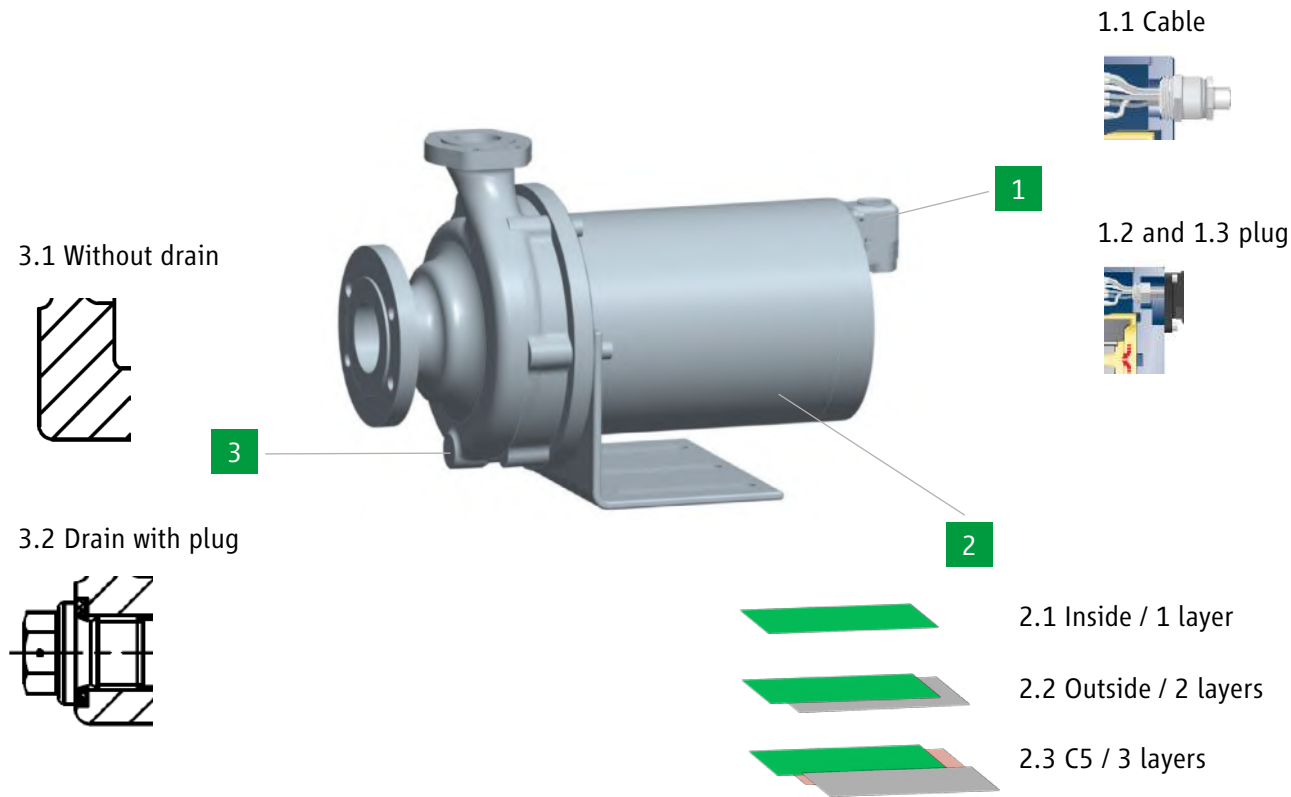

1 Mains connection

- 1.1 Redox cable (standard)
- 1.2 HARTING plug / 4-pole (option)
- 1.3 Weidmüller plug / 6-pole (option)

2 Paintwork

- 2.1 Inside (~40 µm) (standard)
- 2.2 Outside (~120 µm) (option)
- 2.3 C5 (~200 µm) (option)

3 Drain

- 3.1 Without drain (standard)
- 3.2 Drain with plug (option)

Table of Contents

General information

Standard

Operating principle

Characteristic maps

Benefits

Technical data

Documentation and tests

Collective measurements

Modular

Individual adaptations

Contact



Individual adaptations according to customer requirements

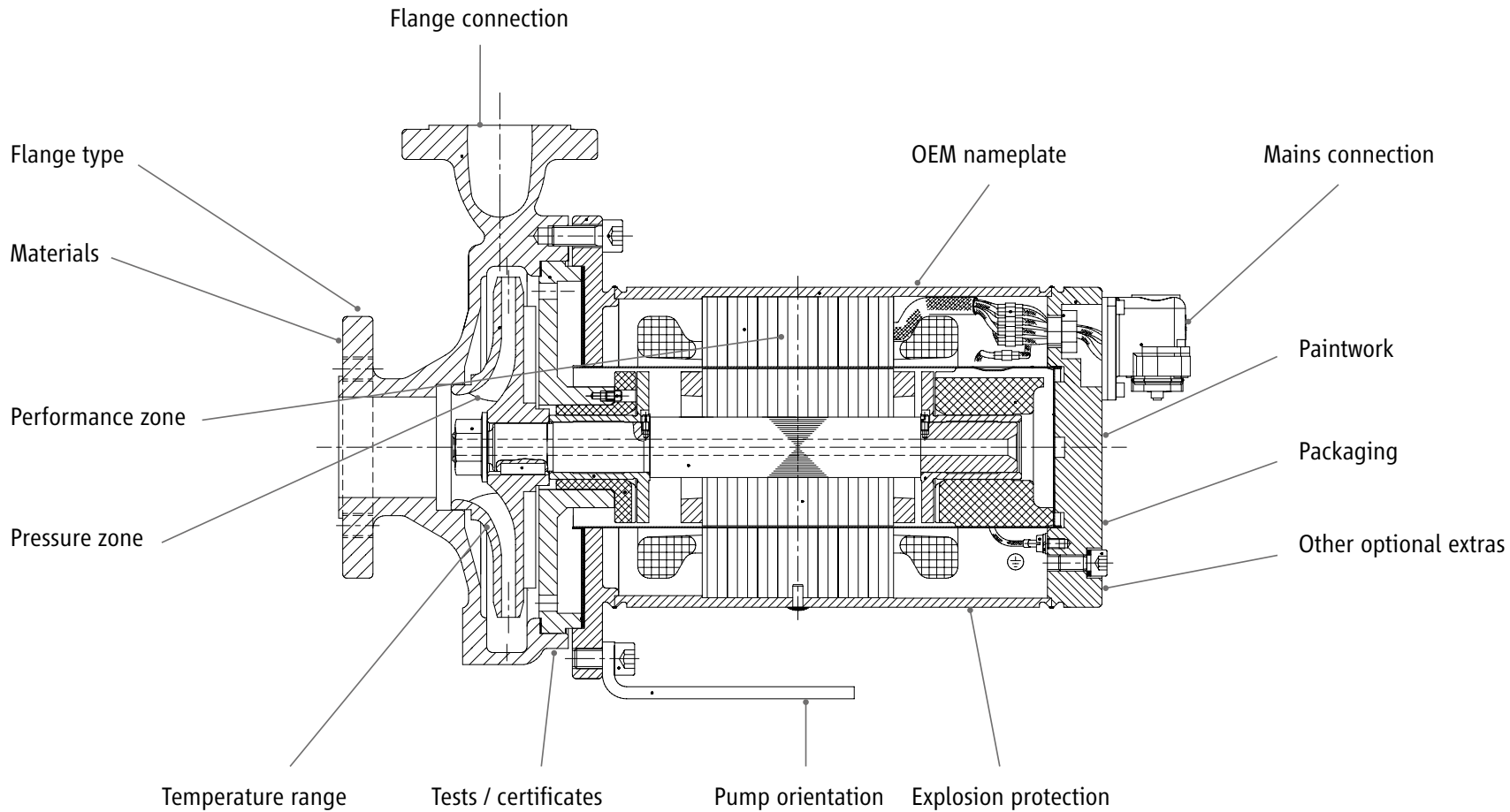

- Table of Contents
- General information
- Standard
- Operating principle
- Characteristic maps
- Benefits
- Technical data
- Documentation and tests
- Collective measurements
- Modular
- Individual adaptations**
- Contact

Do you need a modified LC pump? We can adapt our pumps for you quickly and cost-effectively.

In this case, please contact our technical support:
lc-support@hermetic-pumpen.com



PRODUCT INFORMATION

Contact

lc-support@hermetic-pumpen.com

www.hermetic-pumpen.com

YouTube | LinkedIn | Expert tool

Table of Contents

General information

Standard

Operating principle

Characteristic maps

Benefits

Technical data

Documentation and tests

Collective measurements

Modular

Individual adaptations

Contact

