

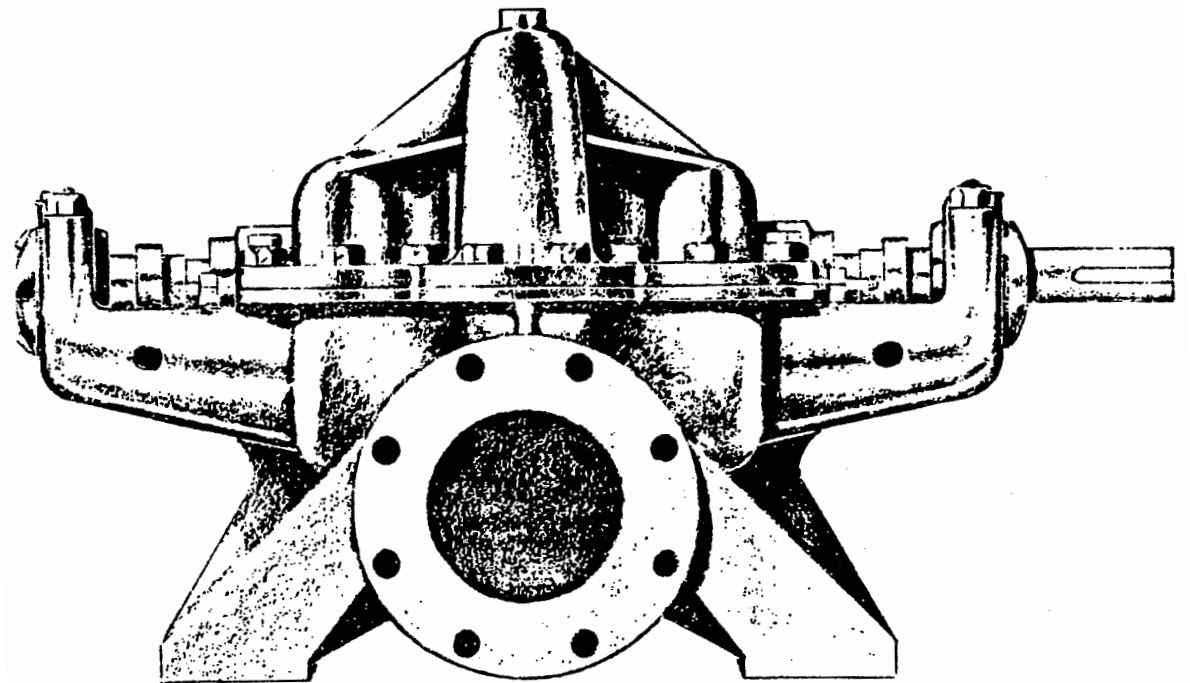

FAIRBANKS NIJHUIS™



MODELS 5800 AND 5800F HORIZONTAL SPLIT-CASE AND FIRE PUMPS WITH NON-REMOVABLE BEARING ARMS

INSTRUCTIONS AND MAINTENANCE MANUAL

NOTE! To the installer: Please make sure you provide this manual to the owner of the equipment or to the responsible party who maintains the system.

TABLE OF CONTENTS

STORAGE OF PUMPS AND CAUTION	3
STANDARD TERMS AND CONDITIONS	4
INTRODUCTION AND GENERAL APPLICATION	6
PUMP AND DRIVER INSTALLATION	6
General	6
Location	6
Foundation	6
Alignment	6
Coupling Alignment	6
Grouting	7
Piping	7
Rotation	7
INITIAL START-UP AND OPERATING INSTRUCTIONS	7
MAINTENANCE	8
Stuffing Box	8
Packing Replacement	8
Pump Disassembly	8
Pump Assembly	9
ORDERING PARTS	9
RETURNING PARTS	9
DRAWINGS:	
Coupling Alignment	10
Sectional — Figure 5800 with impeller wearing rings	11
Sectional — 4" Figure 5826 with casing and impeller wearing rings, mechanical seals and oil lube bearing housing	12
Material Specifications	13
TROUBLE SHOOTING	14
NOTES	15

STORAGE OF PUMPS AND CAUTION

These instructions apply to the pump only. They are intended to be general and not specific. If your operating conditions ever change, always refer to the factory for reapplication. Always refer to the manuals provided by manufacturers of the other equipment for their separate instructions.

CAUTION IMPORTANT SAFETY NOTICE

The installation, use and operation of this type of equipment is affected by various federal, state and local laws and the regulations concerning OSHA. Compliance with such laws relating to the proper installation and safe operation of this type of equipment is the responsibility of the equipment owner and all necessary steps should be taken by the owner to assure compliance with such laws before operating the equipment.

CAUTION CALIFORNIA PROPOSITION 65 WARNING

This product and related accessories contain chemicals known to the State of California to cause cancer, birth defects or other reproductive harm.

STORAGE OF PUMPS

If the equipment is not to be immediately installed and operated, store it in a clean, dry, well ventilated place, free from vibrations, moisture, and rapid or wide variations in temperature.

SPECIAL INSTRUCTIONS FOR:

OIL LUBRICATED PUMPS: Fill the bearing reservoirs with oil. Prior to start up, drain the storage oil and fill the reservoirs to the proper level with new oil.

GREASE LUBRICATED PUMPS: Rotate the shaft for several revolutions at least once every two weeks to:

1. Coat the bearing with lubricant;
2. Retard oxidation or corrosion and;
3. Prevent possible false brinelling.

CONSIDER A UNIT IN STORAGE WHEN:

1. It has been delivered to the jobsite and is awaiting installation.
2. It has been installed but operation is delayed pending completion of construction.
3. There are long (30 days or more) periods between operation cycles.
4. The plant (or department) is shut down for periods of longer than 30 days.

NOTE: Storage requirements vary depending on the length of storage, the climatic environment and the equipment. For storage periods of three months or longer, contact the manufacturer for specific instructions. Improper storage could damage the equipment which would result in non-warranty covered restoration requirements or non-warranty covered product failures.

STANDARD TERMS AND CONDITIONS

LEGAL EFFECT: Except as expressly otherwise agreed to in writing by an authorized representative of Seller, the following terms and conditions shall apply to and form a part of this Quotation and any order resulting therefrom and any additional and/or different terms of Buyer's purchase order or other form of acceptance are rejected in advance and shall not become a part of any order resulting from this Quotation.

The rights of Buyer hereunder shall neither be assignable nor transferable, except with the written consent of Seller.

Any order resulting from this Quotation cannot be cancelled or altered except with the written consent of Seller and upon terms which will indemnify Seller against all loss occasioned thereby. All additional costs incurred by Seller due to changes in design or specifications, modification of any order resulting from this Quotation or revision of product must be paid for by Buyer.

In addition to the rights and remedies conferred upon Seller by any contract resulting from this Quotation, Seller shall have all rights and remedies conferred at law and in equity and shall not be required to proceed with the performance of any order resulting from this Quotation if Buyer is in default in the performance of such order or of any other contract or order with Seller.

PRICES:

A. Prices for items of equipment included in the Quotation, other than equipment noted in Paragraph B, manufactured by Seller, are subject to escalation in accordance with Clause 1 below, unless Clause 2 is specifically stated in the price quotation portion of this Quotation.

CLAUSE 1 — The price for each item of equipment shall be escalated by the percentage increase of the published price for such item after applicable discounts in effect at the time of shipment, over the published price for such items after applicable discounts in effect at the date of this Quotation.

CLAUSE 2 — The quoted price for each item of equipment shall be subject to escalation in accordance with the price adjustment policy specified in Form KC586.

B. Items of equipment purchased by Seller which are not covered by published prices and which are separately identified in this Quotation (such as motors, engines, controls, etc.) will be subject to escalation by the ratio of Seller's purchase price at the time of shipment over Seller's purchase price at the time of this Quotation.

TERMS OF PAYMENT: Unless otherwise specified in this Quotation, the terms of payment shall be as follows:

- a. On all orders under \$100,000, net cash, within thirty (30) days after shipment.
- b. On all orders over \$100,000, as follows:
 - 15% on submittal of drawings
 - 25% on release to manufacture
 - 50% at time of shipment
 - 10% 30 days after shipment

These terms shall apply to partial as well as complete shipments. If any proceeding be initiated by or against Buyer under any bankruptcy or insolvency law, or in the judgment of Seller the financial condition of Buyer, at the time the equipment is ready for shipment, does not justify the terms of payment specified, Seller reserves the right to require full payment, in cash, prior to making shipment. If such payment is not received within fifteen (15) days after notification of readiness for shipment, Seller may cancel the order as to any unshipped item and require payment of its reasonable cancellation charges.

If Buyer delays shipment, payments based on date of shipment shall become due as of the date when ready for shipment. If Buyer delays completion of manufacture, Seller may elect to require payment according to percentage of completion. Equipment held for Buyer shall be at Buyer's risk and storage charges may be applied at the discretion of Seller.

Accounts past due shall bear interest at the highest rate lawful to contract for, but if there is no limit set by law, such interest shall be eighteen percent (18%). Buyer shall pay all costs and expenses, including reasonable attorney's fees, incurred in collecting the same, and no claim, except claims within Seller's warranty of material or workmanship, as stated below, will be recognized unless delivered in writing to Seller within thirty (30) days after date of shipment.

TAXES: All prices exclude present and future sales, use, occupation, license, excise, and other taxes in respect to manufacture, sales, or delivery, all of which shall be paid by Buyer unless included in the purchase price at the proper rate or a proper exemption certificate is furnished.

ACCEPTANCE: This Quotation is not an offer. All offers to purchase, quotations and contracts of sale are subject to final acceptance by an authorized representative at Seller's Kansas City plant.

DELIVERY: Except as otherwise specified in this Quotation, delivery will be F.O.B. cars point of shipment. In the absence of exact shipping instructions, Seller will use its discretion regarding best means of shipment. No liability will be accepted by Seller for so doing. All transportation charges are at Buyer's expense. Time of delivery is an estimate only and is based upon the receipt of all information and necessary approvals. The shipping schedule shall not be construed to limit Seller in making commitments for materials or in fabricating articles under this order in accordance with Seller's normal and reasonable production schedules.

STANDARD TERMS AND CONDITIONS

Seller shall in no event be liable for delays caused by fires, acts of God, strikes, labor difficulties, acts of governmental or military authorities, delays in transportation or procuring materials, or causes of any kind beyond Seller's control. No provision for liquidated damages for any cause shall apply under this order. Buyer shall accept delivery within thirty (30) days after receipt of notification of readiness for shipment. Claims for shortages will be deemed to have been waived if not made in writing within ten (10) days after the receipt of the material in respect of which any such shortage is claimed. Seller is not responsible for loss or damage in transit after having received "In Good Order" receipt from the carrier. All claims for loss or damage in transit should be made to the carrier.

TITLE & LIEN RIGHTS: The equipment shall remain personal property, regardless of how affixed to any realty or structure. Until the price (including any notes given therefore) of the equipment has been fully paid in cash, Seller shall, in the event of Buyer's default, have the right to repossess such equipment.

PATENT INFRINGEMENT: If properly notified and given an opportunity to do so with friendly assistance, Seller will defend Buyer and the ultimate user of the equipment from any actual or alleged infringement of any published United States patent by the equipment or any part thereof furnished pursuant hereto (other than parts of special design, construction, or manufacture specified by and originating with Buyer), and will pay all damages and costs awarded by competent court in any suit thus defended or of which it may have and notice and opportunity to defend as aforesaid.

STANDARD WARRANTY: Seller warrants products of its own manufacture against defects in materials and workmanship under normal use, and service for one (1) year from date of installation or startup, but not more than eighteen (18) months after date of shipment. Accessories and components not manufactured by Seller are warranted only to the extent of the original manufacturer's warranty. Notice of the alleged defect must be given to Seller in writing with all identifying details including serial number, type of equipment and date of purchase within thirty (30) days of the discovery of same during the warranty period. Seller's sole obligation on this warranty shall be, at its option, to repair or replace or refund the purchase price of any product or part thereof which proves to be defective as alleged. No allowances will be made for repairs or alterations effected without specific written authorization from Seller.

If requested by Seller, such product or part thereof must be promptly returned to the manufacturer prior to any attempted repair; or sent to an authorized service station designated by the manufacturer. All shipping expenses are to be prepaid by the buyer. Seller accepts no responsibility for loss or damage in transit of goods, nor will any warranty claim be considered unless the returned goods are received intact and undamaged as a result of shipment. Repaired or replaced material returned to customer will be shipped F.O.B. the manufacturer's factory.

Seller warrants repaired or replaced parts of its own manufacture against defects in materials and workmanship under normal use and service for ninety (90) days or for the remainder of the warranty on the product being repaired. This warranty applies to the repaired or replaced part and is not extended to the product or any other component of the product being repaired.

Under the terms of this warranty, Seller shall not be responsible nor liable for:

- a. Consequential, collateral or special losses or damages.
- b. Equipment conditions caused by fair wear and tear, abnormal conditions of use, accident, neglect, or misuse of said equipment.
- c. Labor charges, loss or damage resulting from the supplying of defective part(s) or improper repairs by unauthorized person(s).
- d. Damage caused by abrasive materials, chemicals, scale deposits, corrosion, lightning, improper voltage or mishandling.

Seller reserves the right to substitute new equipment and/or improve the part(s) on any equipment judged defective without further liability. All repairs and/or services performed by Seller, not adjusted as covered by this warranty, will be charged in accordance with the current equipment and service prices.

This warranty is VOID unless the purchaser provides protective storage, installs and maintains the equipment in accordance with manufacturer's instructions.

Credit will NOT be allowed nor shipment accepted on any part(s) or equipment returned unless prior approval in writing has been obtained.

THIS WARRANTY IS THE SOLE WARRANTY OF SELLER AND ANY OTHER WARRANTIES EXPRESS, IMPLIED IN LAW OR IMPLIED IN FACT, INCLUDING ANY WARRANTIES OF MERCHANTABILITY AND FITNESS FOR USE, ARE HEREBY SPECIFICALLY EXCLUDED.

No employee of the Seller and no agent, dealer or distributor has any authority to change or enlarge the terms of this warranty to obligate the Seller to other than strictly the terms of this written warranty.

LIABILITY LIMITATIONS: Under no circumstances shall the Seller have any liability for liquidated damages or for collateral, consequential or special damages or for loss of profits, or for actual losses or for loss of production or progress of construction, whether resulting from delays in delivery or performance, breach of warranty, negligent manufacture or otherwise. The aggregate total liability of Seller in connection with the performance of this order, whether for breach of contract or warranty, negligence, indemnity or otherwise, shall in no event exceed the contract price. Buyer agrees to indemnify and hold harmless Seller from all claims by third parties in excess of these limitations.

Since the compliance with the various Federal, State and Local laws and regulations concerning occupational health and safety and pollution are affected by the use, installation and operation of the equipment and other matters over which the Seller has no control, the Seller assumes no responsibility for compliance with those laws and regulations, whether by way of indemnity, warranty or otherwise.

KC5851rev 10/821

INTRODUCTION

This manual contains descriptions and instructions which are the results of carefully conducted engineering and research efforts. It is designed for the safe and efficient installation, operation and maintenance of your pump. **Failure or neglect to properly install, operate or maintain your pump may result in personal injury, property damage or unnecessary damage to the pump. Read this manual and all other equipment manuals carefully.**

The purpose of this manual is to supply adequate instructions for installation, operation and maintenance of your pump. However, this manual shall not in any way take precedence over or abrogate the requirements of NFPA 20 for the installation and use of centrifugal fire pumps.

GENERAL APPLICATION

The 5800 pumps are of a horizontal split case design, with the casing being split on the horizontal centerline. Both the suction and discharge flange connections are located below the horizontal casing split. The only moving part is the rotating assembly which rotates using grease lubricated high quality steel ball bearings.

Service of the rotating element is accomplished by unbolting and removing the upper casing half and lifting the rotating element out. This service can be accomplished without disturbing either piping or motor alignment.

The stuffing box packing may be lubricated by the fluid being pumped with a connection from the pressure side of the pump casing to the stuffing box, or by a connection from an outside source directly to the stuffing box.

These pumps may be supplied with mechanical seals, impeller wear rings, and with an oil lubrication system for the bearings.

PUMP AND DRIVER INSTALLATION

General

Carefully read all sections of this manual, which apply to pump and driver installation, prior to beginning work.

Upon receipt of the shipment, unpack and inspect the pump and driver assemblies and individual parts to assure nothing is missing or damaged. Report immediately, to the factory and the transportation company involved, any damage incurred during shipment.

The pump and driver assemblies are mounted on a structural steel base and aligned at the factory. However, the alignment may be disturbed in transit or by leveling of the base on the foundation. Alignment should be checked after the unit is leveled on the foundation, after the grouting has set, the foundation bolts tightened, and again after all piping is accomplished.

When the driver is to be mounted at the installation site, the pump and driver bolt holes are not drilled or tapped. When the pump and driver are mounted on separate base structures, first the pump should be leveled and aligned; then the driver is to be leveled and lined up with the pump.

To facilitate alignment at the installation site, neither the pump nor the driver is doweled to the base structure at the factory.

Location

The pump and driver should be located in an area that will permit periodic inspection and maintenance. Head room should be provided when it is necessary to use cranes. All units should be installed in a dry and dust free location. **WARNING: DO NOT PICK UP THE COMPLETE UNIT BY THE DRIVER OR PUMP.** When it is necessary to move or lift the complete unit, a chain or suitable lifting device should be attached to each corner of the base structure. The individual driver or pump may be lifted by the provided eye bolts. The pump should be installed as near the fluid supply as possible; a short direct suction pipe can be used to hold suction loss to a minimum. The discharge piping should be direct and with as few elbows and fittings as possible.

Foundation

The foundation should be a level surface, sufficient to prevent vibration, and to form a permanent rigid support for the base structure. The most satisfactory foundations are concrete.

Foundation bolts of the proper size should be imbedded in the foundation in pipe sleeves with an I.D. $2\frac{1}{2}$ times larger than the bolt diameter to allow for final positioning of the unit.

Alignment

Lower the unit onto the foundation, positioning the base structure so the anchor bolts are correctly aligned with the holes in the base. Disconnect the coupling halves and **do not reconnect until all alignment operations are complete.** (See Fig. 1).

The base structure should be supported on metal shims or metal wedges. The support pieces should be placed directly under the part of the base carrying the greatest weight and spaced close enough to give uniform support. (See Fig. 1).

Adjust the metal supports or wedges until the shafts of the pump and driver are level. Check the coupling faces, as well as the suction and discharge flanges of the pump, for horizontal or vertical position by means of a level. Corrections can be accomplished by adjusting the supports under the base.

When the pump and driver shafts are pulled toward each other, there should be a $\frac{1}{8}$ " minimum clearance between the shaft ends or as specified on setting plan.

Coupling Alignment

When installing and aligning the coupling, it must be checked **carefully.** A flexible coupling should not be used to compensate for misalignment of the pump and driver. The purpose of a flexible coupling is to compensate for misalignment due to temperature changes and to permit independent end movement of the pump and driver shaft.

Angular alignment is accomplished by inserting a taper or feeler gauge at four points between the coupling faces and comparing the distance between the faces of four points spaced at 90° intervals around the couplings. Rotate each coupling individually and check at all four points. The unit will be in angular alignment when the measurements show that the coupling faces are the same distance apart at each point. (See Fig. 2).

Parallel alignment is accomplished by placing a straight edge across both coupling rims at the top, bottom and both sides. The unit will be in parallel alignment when the straight edge rests evenly on both coupling rims at all four positions. Care must be taken to hold the straight edge parallel to the axis of the shaft. (See Fig. 3). NOTE: for couplings other than FM, refer to the coupling manufacturer's alignment instructions.

Coupling misalignment is corrected by placing shims under the driver or pump mounting feet. After each change, recheck the alignment of the coupling halves. Adjustment in one direction may disturb adjustments already made in another direction. Alignment can also be obtained by the use of dial indicators.

Grouting

When the alignment is correct, the foundation bolts should be tightened evenly, but not too firmly. The unit should now be grouted using a high grade, non-shrinking grout. The inside of the base structure should be filled to the top of the side rails with grout.

Allow the grout to fully cure; then fully tighten the foundation bolts, and start piping.

CAUTION: DO NOT ATTEMPT TO OPERATE THE PUMP BEFORE THE GROUT IS FULLY CURED.

Piping

All piping should be independently supported near the pump so pipe strain will not be transmitted to the pump casing. The suction pipe must be air tight and sloped upward to the pump flange to avoid air pockets which will impair satisfactory pump operation. The pump must never be throttled by the use of a valve in the suction line. The discharge pipe should be as direct as possible with a minimum number of fittings to reduce pipe friction losses. The suction and discharge piping should be one or two sizes larger than the pump flange sizes, especially where the piping is of considerable length. Eccentric reducers should be used on the suction line to increase suction line size. The use of an eccentric reducer will help to avoid air pockets in the line. A check valve and gate valve should be used in the discharge line. The check valve, placed between the pump and the gate valve, is to prevent reverse rotation. The gate valves are used in priming and starting when the pump is to be shut down. For nominal suction lift, a foot valve in the suction line will facilitate priming.

In a new installation, care should be taken to prevent dirt, pipe scale, welding beads, or any other foreign matter from entering the pump. The suction system should be thoroughly flushed; if the liquid being pumped contains foreign matter, a strainer should be installed in the suction. The strainer must have a net area of at least three times the area of the suction pipe.

IMPORTANT: WHEN CONNECTING PIPING TO THE PUMP, THE CONNECTION SHOULD BE MADE WITH THE PIPE IN A FREE SUPPORTED STATE WITHOUT THE NEED TO APPLY VERTICAL OR SIDE PRESSURE TO OBTAIN ALIGNMENT OF THE PIPING WITH THE PUMP FLANGE. THRUST BLOCK AND PIPE SUPPORTS SHOULD BE INSTALLED TO PREVENT DAMAGE TO THE PUMP.

CAUTION: AFTER ALL PIPING IS CONNECTED, THE PUMP AND DRIVER ALIGNMENT SHOULD BE RECHECKED.

Rotation

Before connecting the two coupling halves, start the driver and verify that the rotation is in the proper direction. The motor should be run long enough to check for smooth operation. The correct pump rotation is indicated by a directional arrow on the upper half pump casing.

INITIAL START-UP AND OPERATING INSTRUCTIONS

Variations may exist in both the equipment used with the pump and in particular installation of the pump and driver. Therefore, specific operating instructions are not within the scope of this manual. However, there are some general rules and practices that apply to all pump installation and operation procedures:

CAUTION: BEFORE STARTING AND OPERATING THE PUMP, READ THE FOLLOWING INSTRUCTIONS.

1. Before starting pump, install coupling guards around exposed rotating parts as required.
2. Before starting pump, rotate the unit by hand to assure all moving parts are free.
3. Observe *all* caution or danger tags attached to the equipment.
4. Never run the pump dry, as the close running fits within the pump are water lubricated. Running dry may result in pump seizure.
5. Before starting the pump, the casing and suction line must be filled with water. The pump may be primed by using an ejector exhausted vacuum pump or by filling and venting with a foot valve on the suction line.
6. Refer to the instruction manuals provided by the manufacturers of other equipment (used with the pump) for installation, operation and maintenance instructions.
7. If excessive vibration or noise occurs during start up, shut the pump down and consult your nearest Fairbanks Morse representative. Only Fairbanks Morse qualified representatives should be engaged to service this equipment.
8. Keep the stuffing box adjusted so there is sufficient leakage to lubricate the packing and assure a cool stuffing box. (See maintenance instructions).
9. If the pumps are stored for a long period of time prior to installation and operation, refer to Fairbanks Morse "Storage of Pumps Notice," Form KC1309, for applicable instructions.

MAINTENANCE

Fairbanks Morse pumps are equipped with high grade anti-friction bearings, which are lubricated at the factory for approximately six months average service. Periodic inspections should be made by loosening the bearing covers enough to permit visual examination of the bearings. The cover and bearing and bearing cavity should be approximately half full of lubricant.

The pump is equipped with pressure gun fittings for each bearing. The bearings should be lubricated with a Lithium Base NLGI 2 grease from a reputable manufacturer. **WARNING: DO NOT ATTEMPT TO LOOSEN BEARING COVERS OR LUBRICATE BEARINGS WHILE PUMP IS RUNNING.** In the event the pumps are in service and operating in an area having high ambient temperatures, special greases may be required. Contact a lubrication engineer or a Fairbanks Morse representative.

Immediately after lubrication, bearing temperature may rise above normal operating temperature. This should stabilize within 4 to 8 hours. The frequency of lubrication depends on the operating conditions.

If the bearings are oil lubricated, use a good grade of SAE 20 automotive type oil (either detergent or non-detergent) which contains nonfoaming, nonoxidation and rust inhibiting agents.

If the pump is supplied with a constant level oiler, assemble the oiler to the bearing housing. The oiler is located in a way to predetermine the oil level in the housing. Fill the oiler and let it drain into the housing until the oil level remains constant in the sight glass. When this is accomplished, the correct oil level is attained.

Stuffing Box

The stuffing boxes on Fairbanks Morse pumps are packed at the factory with a good grade of packing. However, all packing is subject to wear and should be given regular inspections and, if necessary, adjusted or replaced.

Adjustment is accomplished by tightening the gland nuts, wrench tight, and then loosening so they can be adjusted with finger pressure to allow a small flow of liquid to lubricate the packing. If the flow of liquid has increased and cannot be reduced by a slight tightening of the glands, it is time to replace the packing and/or shaft sleeve.

CAUTION: DO NOT TIGHTEN THE GLAND TO STOP ALL LEAKAGE. LEAKAGE IS NECESSARY TO INSURE THE COOLING AND LUBRICATION OF THE PACKING AND TO PREVENT SLEEVE DAMAGE.

Water lubrication is supplied to the stuffing box by a connection to the pressure side of the pump casing, or by a connection from an outside source directly to the stuffing box.

Packing Replacement

When replacing packing, use a good grade of soft square synthetic packing, graphite impregnated. The replacement procedure should be as follows

- A. Unbolt and remove the split gland.
- B. Use a packing hook to remove the worn packing and water seal rings. Note location of water seal ring, relative to the amount of packing on each side of the ring.
- C. Clean the packing box and shaft sleeve.
- D. Inspect the shaft sleeve for wear or rough finish. (Replace if necessary.)
- E. Install the new packing and water seal ring. Stagger the packing end joints 180° and firmly seat each packing ring.
- F. Reinstall the split gland and tighten the gland nuts wrench tight.
- G. Loosen the gland nuts so they can be adjusted with finger pressure to obtain correct leakage for lubrication, after start-up.

Pump Disassembly

Major pump maintenance, beyond lubrication and adjustment or replacement of packing, will require disassembly of the pump. When disassembly is necessary the following step by step procedure will apply.

- A. Lock out the power to the driver and close the suction and discharge valves; drain the pump. Disconnect the couplings between the pump and driver. Remove the oilers, if the pump is equipped with an oil lubrication system.
 - B. Remove the casing cap screws, gland, gland nuts, split glands, bearing caps and upper casing.
 - C. Using a double rope sling, remove the rotor assembly from the lower casing.
 - D. Remove the cap screws in the bearing covers. Remove the bearing housings.
 - E. Remove the lock washer and nut from the thrust bearing end.
 - F. With the assistance of a bearing puller, remove both bearings.
 - G. Remove bearing covers, lip seals, casing wear rings, water seal rings and stuffing box packing. If the pump is equipped with mechanical seals, refer to the mechanical seal instructions supplied with the pump. If the pump is equipped with an oil lubrication system, remove the "O" rings from the bearing covers.
 - H. Remove the shaft sleeve nuts and stuffing box bushings.
- IMPORTANT: THE SHAFT SLEEVES AND NUTS ARE SECURED WITH LOCTITE RETAINING COMPOUND. TO REMOVE, HEAT UNIFORMLY TO 350° F-450° F TO SOFTEN LOCTITE.**

WARNING: USE HEAT RESISTANT GLOVES WHEN HANDLING HOT PARTS.

- J. Slide the impeller off the shaft and remove the impeller key. At this time, note or mark the impeller and the shaft to assure proper rotation when reassembling.

After the pump is disassembled, each part should be thoroughly cleaned, and inspected for wear or damage. Any parts showing signs of wear or damage should be replaced.

The pump may be equipped with impeller wearing rings. If the rings require replacement, remove the dowel screws and chisel/cut the rings at the dowel hole locations. If the rings are threaded on, remove the dowel screws and unscrew the rings from the impeller.

Pump Assembly

Instructions for assembly of the pump will be essentially the reverse of the instructions for disassembly. However, some special techniques are required.

CAUTION: READ THE ASSEMBLY INSTRUCTION CAREFULLY PRIOR TO BEGINNING WORK.

- A. If the pump is equipped with impeller wearing rings, install the new rings with a press or by using a hammer and a block of wood. Redowel 15°-20° from old dowel location. If the rings are a threaded configuration, screw each ring on the impeller the full depth of the threads and redowel.
- B. Thoroughly clean the pump shaft to remove oil, grease and other types of foreign materials. Insert the impeller key into the keyway slot on the pump shaft. Slide the impeller onto the shaft and over the key, assuring the impeller is in proper rotation.
- C. Apply a bead of Loctite,[®] Catalog 271 or 601, around the shaft approximately 2 inches from the impeller hub and at the threaded end where the shaft sleeve nut is installed. With a rotating motion, slide the shaft sleeves over the shaft until they butt firmly against the impeller hub. Install stuffing box bushings. Apply 2 to 3 drops of Loctite[®] 271 or 601, to the shaft threads and install the shaft sleeve nuts. To accomplish linear positioning of the impeller, leave an equal amount of threads exposed on each end of the shaft after the nuts are installed and properly tightened.

CAUTION: LINEAR POSITIONING OF THE IMPELLER MUST BE OBTAINED AND THE SHAFT SLEEVE NUTS MUST BE TIGHTENED WITHIN 10 MINUTES AFTER THE LOCTITE IS APPLIED. ALLOW 4 HOURS AFTER LOCTITE IS APPLIED BEFORE OPERATING PUMP.

- D. If slingers are used, install one on each end of the pump shaft. Install lip seals in the bearing covers. NOTE: If the pump is equipped with a constant level oiler, install the "O" rings in the bearing covers. Install radial and thrust bearing covers on shaft.
- E. Install both radial and thrust bearings. Pack each bearing approximately half full with a Lithium Base NLGI 2 All Purpose bearing grease. Replace the thrust bearing lock washer and lock nut. NOTE: the pump is designed to have .000 to .001 interference fit between the bearings and the shaft.
- F. The thrust bearing housing is the one with the snap ring. Slip this housing over the thrust bearing, the bearing with the lock nut, and bolt to the bearing cover. Next, slip on the remaining housing and bolt to the bearing cover. Next, slip on the remaining housing and bolt on the bearing cover. If grease lubricated, install the grease fittings.
- G. Position casing wear rings on the impeller and lower the rotor assembly into position in the lower casing, using a double rope sling. Install the split gland eyebolts in casing.

CAUTION: BE SURE THE BEARING ARM DOWEL PINS ARE FULLY INSERTED INTO THE BEARING HOUSINGS.

H. Inspect the upper casing to assure that the water passages are clean and free of foreign materials. Apply a small amount of grease to the gasket between the upper and lower casings; position pins in the casing wear rings to align with the slots in lower casing. Lower the upper casing into position and insert casing taper pins, tapping the pins lightly with a hammer; insert and tighten the four bolts at stuffing box. Now turn the rotating assembly by hand. If there is increased drag, remove the upper casing and check for a cocked wear ring or foreign material between the ring and casing. Install all bolts and tighten. Recheck for free rotation. A new gasket should be used.

- I. Install packing, water seal rings and split glands. (See packing replacement section of this manual.)

Ordering Parts

When ordering spare or replacement parts, give the pump serial number, size and figure number and a complete description (and item number) of each part. Refer to the drawing and parts list in the back of the manual. Your order may be forwarded to your nearest Fairbanks Morse distributor directly to the factory. NOTE: The upper and lower casing is always furnished as an assembly.

Returning Parts

All materials or parts returned to the factory must have prior approval and an Fairbanks Morse "Returned Goods Tag" to accompany them. Unnecessary delays and wasted efforts will be avoided by using the proper procedure in returning parts or equipment.

Contact your nearest Fairbanks Morse distributor, listing the material to be returned and the reasons for the return. He will contact the factory to obtain approval for the return and to obtain the necessary "Returned Goods Tag" if the return is approved. You will be notified of the reasons if the approval is not given.

All material to be returned should be carefully packed to avoid damage in route from rough handling or exposure to weather. The "Returned Goods Tag" will give shipping instructions. All material is to be returned freight prepaid unless otherwise instructed.

This company makes improvements on its products from time to time and reserves the right to furnish improved parts for repairs when such parts are interchangeable. A part that is received and is not identical in appearance, or has a different symbol from the original part, may be interchangeable. Examine the part carefully before contacting your Fairbanks Morse representative. The parts should never be returned to the factory without first obtaining proper authorization from your Fairbanks Morse representative.

COUPLING ALIGNMENT

FIGURE 1

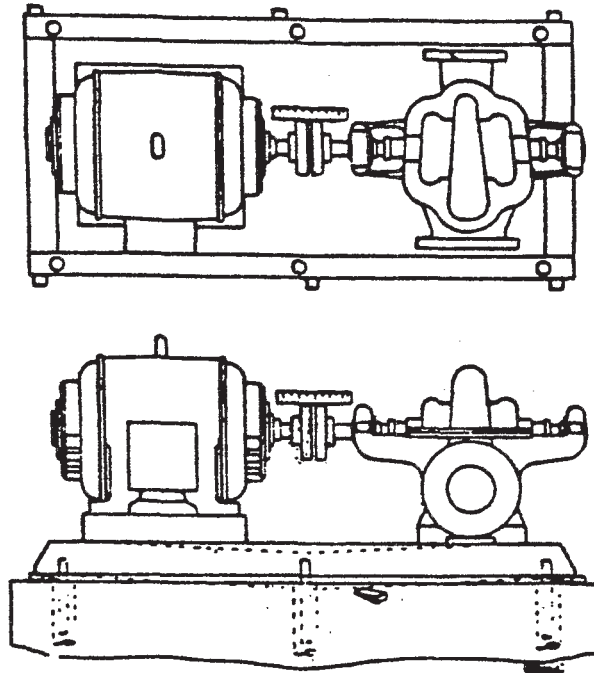

ANGULAR ALIGNMENT

FIGURE 2

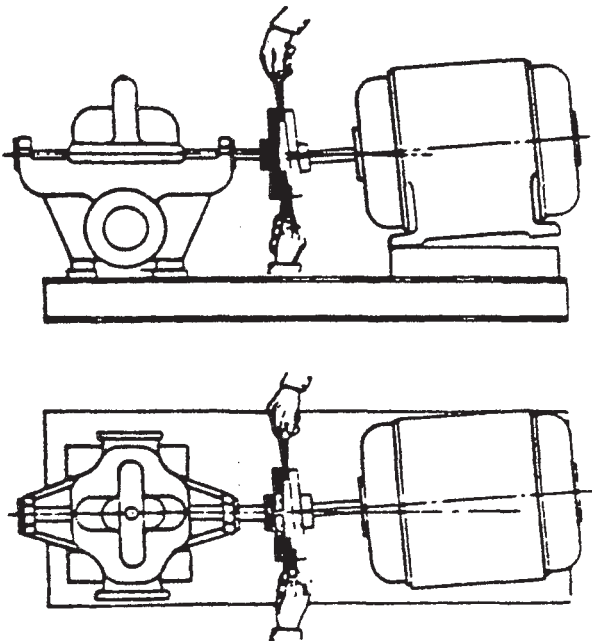

PARALLEL ALIGNMENT

FIGURE 3

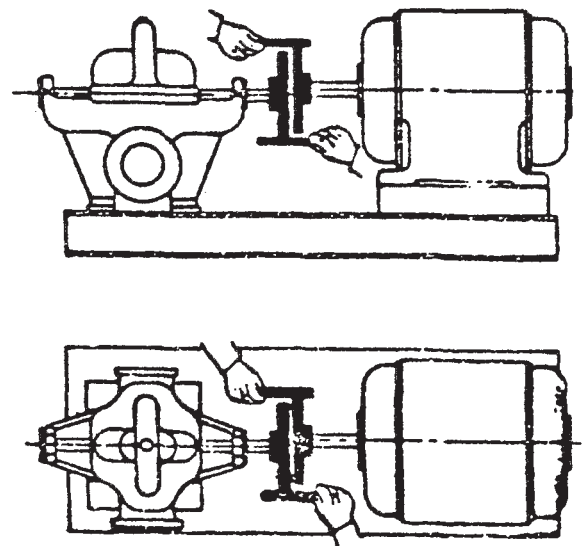

5800 DOUBLE SUCTION SPLIT CASE PUMPS WITH IMPELLER WEARING RINGS AND PACKING

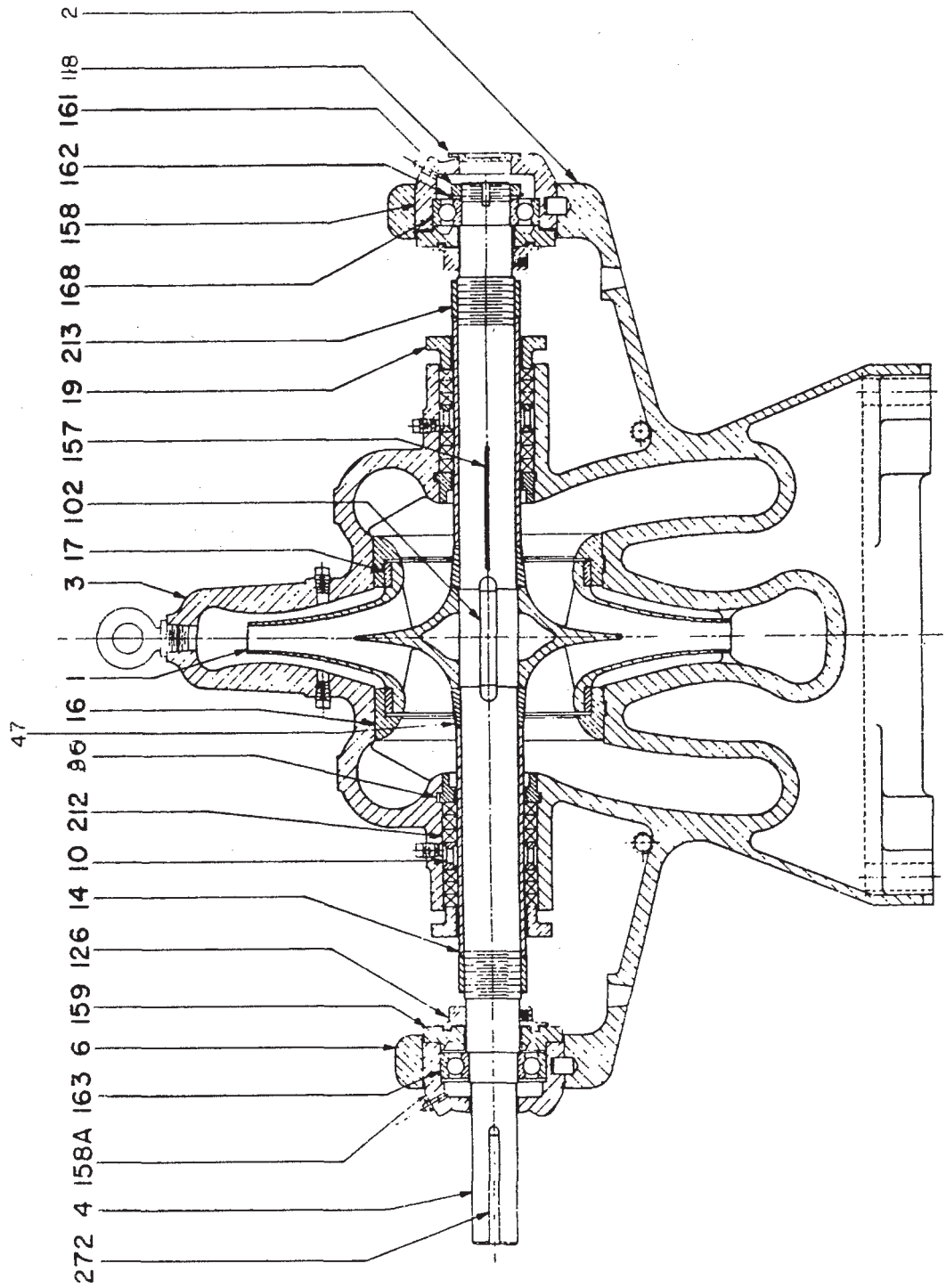

5800 DOUBLE SUCTION SPLIT CASE PUMPS WITH IMPELLER AND CASING WEARING RINGS
AND MECHANICAL SEALS

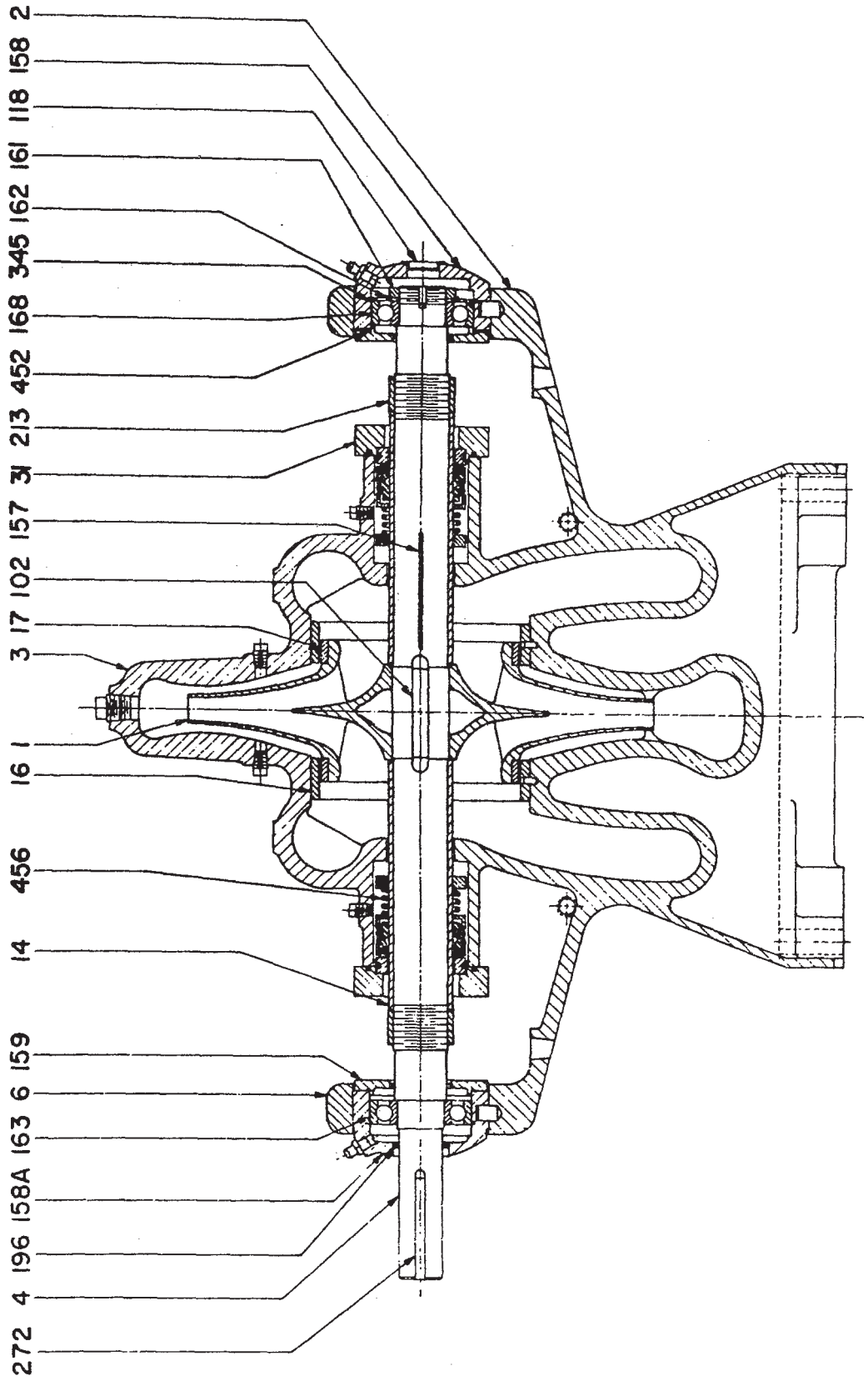

REF. NO.	DESCRIPTION
1	Impeller
2	Casing — Lower
3	Casing — Upper
4	Shaft
10	Ring, Water Seal
13	Pick-up Rings
14	Sleeve, Shaft
16	Wear Ring, Casing
17	Wear Ring, Impeller
19	Gland
102	Key, Impeller
118	Closure
126	Deflector
157	Gasket, Casing
158	Housing, Thrust Bearing (O.B.)
158A	Housing, Radial Bearing (I.B.)
158B	Seal, Bearing Housing
159	Covers, Bearing Housings
159A	Seal, Bearing Cover
163	Bearing, Radial (Inboard)
168	Bearing, Thrust (Outboard)
212	Packing
213	Nut, Shaft Sleeve
272	Key, Coupling
345	Snap Ring
452	“O” Ring, Bearing Housing
456	Mechanical Seal
N/S	Bolts, Gland
N/S	Nuts, Gland
N/S	Nuts and Bolts, Exterior

TROUBLE SHOOTING GUIDE**NO DISCHARGE**

- | | |
|---------------------|---|
| 1. Pump not primed. | 1. Check for proper venting of casting.
2. Check for and remove any obstruction in suction line. |
| 2. Speed too low. | 1. Determine whether or not the motor is across the lines and receives full voltage.
Correct if required.
2. See — Excessive power consumption. |

INSUFFICIENT DISCHARGE

- | | |
|--------------------------------|---|
| 1. Speed too low. | 1. Determine whether or not the motor is across the lines and receives full voltage.
Correct if required.
2. See — Excessive power consumption. |
| 2. Impeller partially plugged. | 1. Remove upper half casing and clean impeller as required. |
| 3. Obstruction in piping. | 1. Remove upper half casing and clean impeller as required. |

INSUFFICIENT PRESSURE

- | | |
|----------------------------|---|
| 1. Speed too low. | 1. Determine whether or not the motor is across the lines and receives full voltage.
Correct if required.
2. See — Excessive power consumption. |
| 2. Excessive Wearing Ring. | 1. Correct as outlined in Maintenance section. |

EXCESSIVE POWER CONSUMPTION

- | | |
|----------------------------|--|
| 1. Rotating element binds. | 1. Remove upper half casing and correct as required. |
| 2. Packing too tight. | 1. Loosen gland nuts and retighten finger tight. |
| 3. Bearings defective. | 1. Replace as outlined in Assembly section. |
| 4. Coupling misaligned. | 1. Correct as outlined in Alignment section. |

EXCESSIVE STUFFING BOX LEAKAGE

- | | |
|---------------------------|--|
| 1. Packing too loose. | 1. Tighten gland nuts, finger tight. |
| 2. Insufficient packing. | 1. Add packing as outlined in Assembly section. |
| 3. Shaft sleeves grooved. | 1. Replace sleeve as outlined in Assembly section. |

VIBRATION OR NOISE

- | | |
|----------------------------|---|
| 1. Coupling misalignment | 1. Correct as outlined in Coupling Alignment section. |
| 2. Foundation bolts loose. | 1. Correct as outlined in Foundation section. |
| 3. Rotating element binds. | 1. Remove upper half casing and correct as required. |
| 4. Packing too tight. | 1. Loosen gland nuts and retighten, finger tight. |
| 5. Bearings defective | 1. Replace as outlined in Assembly section. |

BEARINGS OVER-HEATING

- | | |
|----------------------------|--|
| 1. Coupling misalignment. | 1. Correct as outlined in Coupling Alignment section. |
| 2. Excessive grease. | 1. Remove bearing housing plugs and allow excess to drain. |
| 3. Rotating element binds. | 1. Remove upper half casing and correct as required. |

STUFFING BOX OVER-HEATING

- | | |
|--|---|
| 1. Packing too tight. | 1. Loosen gland nuts and retighten, finger tight. |
| 2. Water line to stuffing box plugged. | 1. Disconnect line and correct as required. |

THIS PAGE INTENTIONALLY LEFT BLANK

THIS PAGE INTENTIONALLY LEFT BLANK