

# VERTICAL TURBINE SOLIDS HANDLING (VTSH) PUMPS



# INTRODUCTION

Unattended pump stations require pumps that you know are reliable and will keep working, no matter what. Downtime is not an option: You demand sustained high performance, the best possible design to resist clogging, and minimum-size driving motors and controls to reduce construction and operating costs.

Pentair Fairbanks Nijhuis Vertical Turbine Solids Handling pumps (VTSH) meet such municipal demands, and then some.

## APPLICATIONS

- ◆ Sewage lift stations
- ◆ Water treatment plants
- ◆ Fibrous sludge and slurry handling
- ◆ Pulp handling
- ◆ General industrial solids handling
- ◆ Flood and storm water control
- ◆ Wastewater collection and treatment

VTSH Pumps	
Discharge Sizes (inches) Discharge Sizes (mm)	Up to 48" Up to 1,220 mm
Capacities (GPM) Capacities (m <sup>3</sup> /h)	5,000 to 80,000 GPM 1,135 to 18,160 m <sup>3</sup> /h
Heads (ft) Heads (m)	10 to 110 ft 3.05 to 33.5 m
Nominal Bowl Diameters (inches) Nominal Bowl Diameters (mm)	10", 14", 16", 20", 24", 30", 36", 42", 48" 254 mm, 356 mm, 406 mm, 508 mm, 610 mm, 762 mm, 914 mm, 1,070 mm, 1,220 mm
Solids Passing Capability (inches) Solids Passing Capability (mm)	3" to 8" 76 to 203 mm



# BETTER BY DESIGN

## REDUCED CONSTRUCTION COSTS

The VTSH pump design puts the entire drive system and controls above the flood plane and is compatible with virtually any drive system. This design means your personnel don't have to enter wet wells for routine maintenance.

A single-sump design eliminates the need for an additional or dry sump, suction piping, dehumidification or sump pumps. This can lead to savings of up to 70% on total construction costs compared to conventional wet-pit/dry-pit designs.

This superior design makes VTSH pumps substantially more efficient over a broad capacity range than conventional solids-handling pumps.

## VERSATILE AND COMPACT

The VTSH is a natural fit for space-saving pump applications such as conventional wet wells, self-cleaning and confined wet wells.

The VTSH provides a solution when the pump station design calls for a single pit or wet well design. Wet wells can be configured into self-cleaning trench type with the pump parallel to the flow, or confined type with the pump alignment normal to the flow. The VTSH is ideally suited for both geometries and both are excellent for eliminating odors by ridding the wet well of heavy debris and floatables.



# FEATURES

## STANDARD FEATURES

### 1. SUCTION BELL

- ◆ Straightening vanes to improve intake flow
- ◆ Sized to limit intake velocity at the bell lip
- ◆ No tail bearing to prevent media from collecting on support vanes

### 2. IMPELLER

- ◆ 2-vane design that can handle solids ranging from 3" on our smallest size to 8" on our largest
- ◆ Overhung design typical of solids handling pumps

### 3. DIFFUSER BOWL

- ◆ 3-vane design that gradually transfers from a radial flow to axial flow
- ◆ Bronze-backed rubber bowl bearings
- ◆ Impeller throttle ring to reduce lower shaft deflection

### 4. COLUMN AND SHAFT CONNECTION (NOT SHOWN)

- ◆ Enclosed lineshaft with intermitten to continous water flushing required
- ◆ Column fitted with splitter vane to minimize debris from wrapping around enclosed shaft

### 5. DISCHARGE HEAD (NOT SHOWN)

- ◆ Custom-engineered fabricated steel design
- ◆ Head fitted with splitter vane to minimize debris from wrapping around enclosed shaft
- ◆ Quad-designed supports added if variable speed application

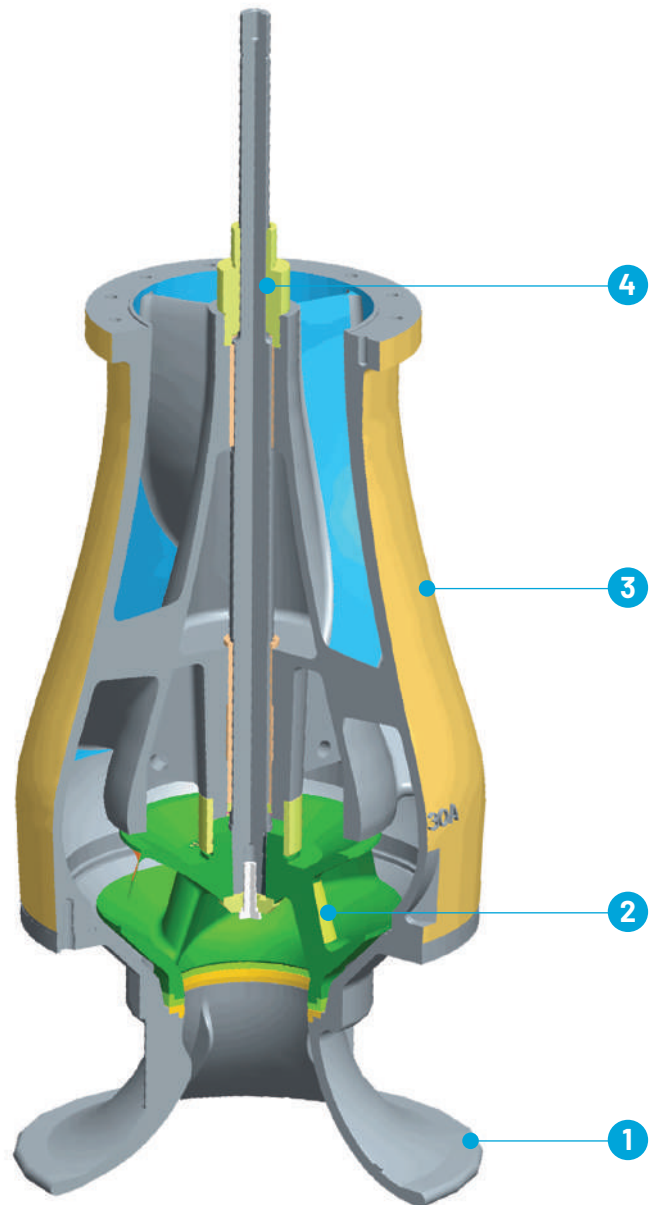

# EFFICIENT PERFORMANCE SETS US APART

## 1. VTSH PUMPS

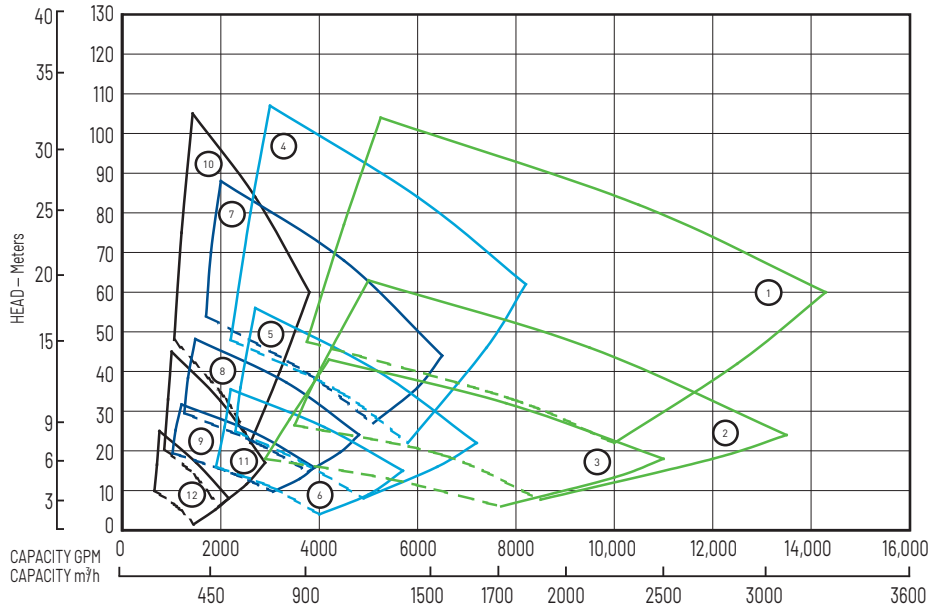

10 to 20 in, 25 to 51 cm			
Number	Inches	Meters	Speed
1	20"	510 mm	880 RPM
2	20"	510 mm	705 RPM
3	20"	510 mm	585 RPM
4	16"	400 mm	1180 RPM
5	16"	400 mm	880 RPM
6	16"	400 mm	705 RPM
7	14"	360 mm	1180 RPM
8	14"	360 mm	880 RPM
9	14"	360 mm	705 RPM
10	10"	250 mm	1770 RPM
11	10"	250 mm	1170 RPM
12	10"	250 mm	880 RPM

## 2. VTSH PUMPS

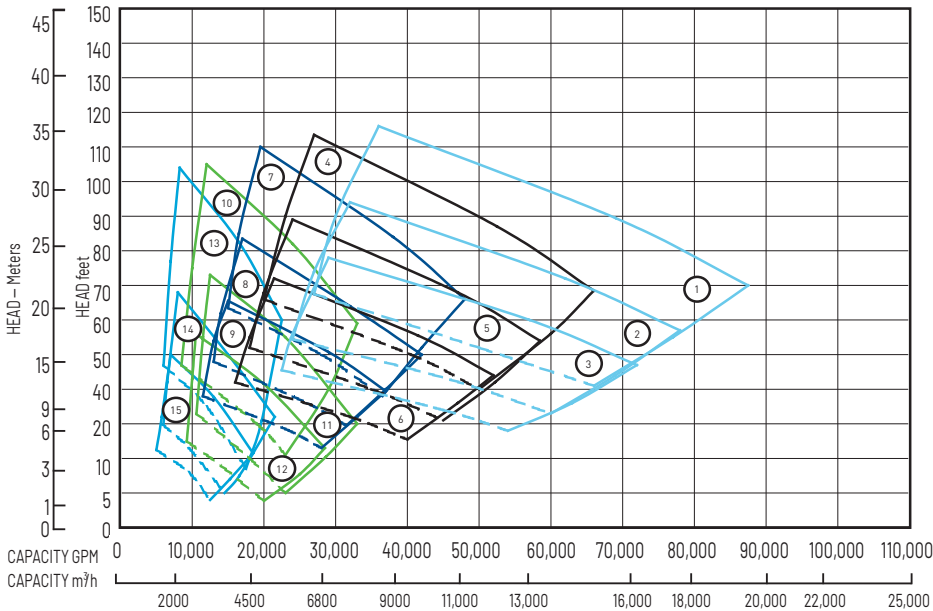

24 to 48 in, 61 to 122 cm			
Number	Inches	Meters	Speed
1	48"	1220 mm	390 RPM
2	48"	1220 mm	350 RPM
3	48"	1220 mm	320 RPM
4	42"	1070 mm	440 RPM
5	42"	1070 mm	390 RPM
6	42"	1070 mm	350 RPM
7	36"	920 mm	505 RPM
8	36"	920 mm	440 RPM
9	36"	920 mm	390 RPM
10	30"	760 mm	585 RPM
11	30"	760 mm	505 RPM
12	30"	760 mm	440 RPM
13	24"	610 mm	705 RPM
14	24"	610 mm	585 RPM
15	24"	610 mm	505 RPM

# PERFORMANCE DATA

## 3. VTSH-LH PUMPS

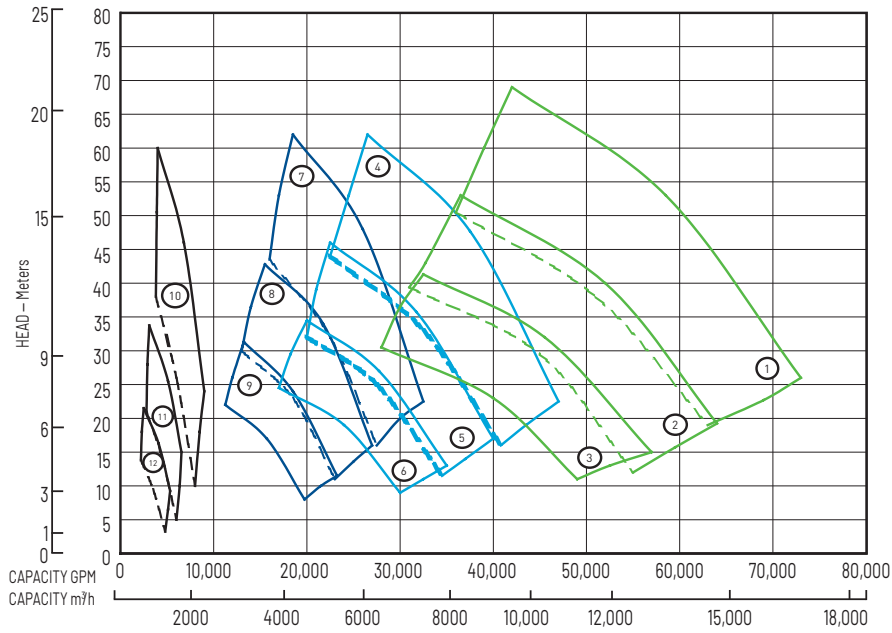

20 to 42 in, 51 to 107 cm			
Number	Inches	Meters	Speed
1	42"	1070 mm	505 RPM
2	42"	1070 mm	440 RPM
3	42"	1070 mm	390 RPM
4	36"	920 mm	585 RPM
5	36"	920 mm	505 RPM
6	36"	920 mm	440 RPM
7	30"	760 mm	705 RPM
8	30"	760 mm	585 RPM
9	30"	760 mm	505 RPM
10	20"	510 mm	1180 RPM
11	20"	510 mm	880 RPM
12	20"	510 mm	705 RPM





# YOUR PUMP PARTNER FOR THE ENTIRE BUILDING

Protecting legacies like yours for generations

In your daily work, you need a trusted source of rugged reliability in mission-critical applications. Generations of our engineers have built, maintained, and evolved pumps to protect buildings like yours around the globe. With over 200 years of expertise and standing by our promises, we have built a robust portfolio that covers your needs.

Whether it's fire suppression for safety or HVAC and boosting applications for comfort, your building is covered with dynamic water movement solutions that fit your needs.

Because every decision counts when selecting pump equipment that protects your building and the people inside.



**EXPLORE OUR PUMP  
PORTFOLIO**

**FIRE SUPPRESSION • HVAC  
PRESSURE BOOSTING**



**KANSAS CITY, USA**  
3601 Fairbanks Avenue  
Kansas City, KS 66106  
PH: 913.371.5000

**THE NETHERLANDS**  
Parallelweg 4  
7102 DE Winterswijk  
PH: +31 (0) 543 547474

[pentair.com/fairbanks-nijhuis](https://pentair.com/fairbanks-nijhuis)



All indicated Pentair trademarks and logos are property of Pentair. Third party registered and unregistered trademarks and logos are the property of their respective owners.

©2026 Pentair. All Rights Reserved.

FM-02-1508 (04-30-26)