

## Vacuum units for profile extrusion

*BluSystems – reduced energy consumption,  
easy installation and simple operation*

# Energy saving and function

## Intelligent vacuum units reduce operating costs

### Leakage air supply is wasted energy

The vacuum and discharge pumps are responsible for most of the power consumption in calibration tables. Up to now, they have been selected based on the high suction capacity requirement during the start-up process for calibration.

To achieve the significantly lower suction capacity requirement in the subsequent operating state, systems are still used which supply leakage air or which throttle the vacuum pumps on the suction side. The electrical power consumption of the vacuum pumps remains consistently high - a completely unnecessary waste of energy.

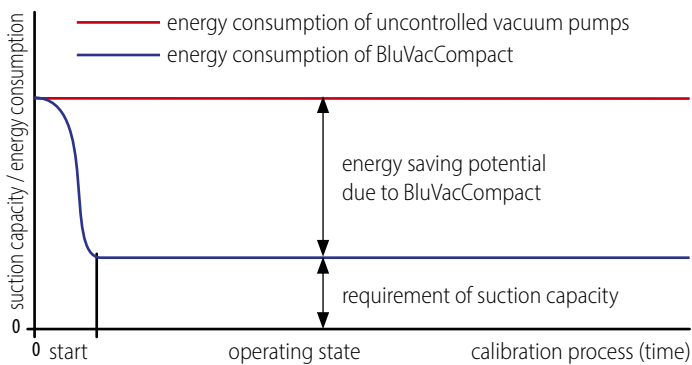

### Energy saving with BluSystems

The enormous energy saving with BluSystems is achieved by not adding leakage air. If smaller suction volumes or a lower vacuum is required after the profile has been calibrated, an internal control automatically reduces the speed of the electric motors, thereby lowering both the vacuum generation and the electrical power consumption. This demand-based vacuum generation saves large amounts of energy during the production process, which can run over several days in some cases.

The pressure level set on the calibration tools by the machine operator is monitored and maintained automatically through the ongoing pressure measurements and speed adjustments. Process-related pressure fluctuations are compensated with no intervention from the machine operator.

A second energy-saving effect is also achieved with the reduced operating water cooling requirements, because, at reduced speeds, the vacuum pumps also introduce less energy into the operating water.

### Maximum efficiency

The biggest energy efficiency with BluSystems vacuum units is achieved by:

- » Using optimized tools, which manage without the use of leakage air as far as possible
- » Selecting the correct size and type of vacuum unit
- » Using the shortest possible suction lines with a suitable diameter



### Animation

Scan the QR code and see exactly where energy can be saved in the process of profile calibration and how easily BluVac vacuum units can be retrofitted. Or visit our website [www.speck.de](http://www.speck.de)

## The saving – a calculation example from practice

Sector: Window profile extrusion

With preproduction series models of BluVac vacuum units, a renowned window profile manufacturer achieved an average saving of 67%. An existing extrusion line was upgraded.

**Before** Range with 3 uncontrolled vacuum pumps, type VN 125, electrical power consumption (P1)  $3 \times 5.2 \text{ kW} = 15.6 \text{ kW}$

**After** Range with 3 BluVac vacuum units, electrical power consumption (P1)  $3 \times 1.1 \text{ kW} = 3.3 \text{ kW}$

The reduced power consumption of 12.3 kW resulted in a saving of 49,200 kWh with an estimated 4,000 operating hours a year.

With an estimated € 0.10 per kWh, **this is a saving of € 4,920,-- per year.**

The lower operating water consumption of BluVac vacuum units also results in reduced energy consumption for operating water cooling.

The calibration process is automated by the integrated control.

BluVac vacuum units therefore pay for themselves quickly.

# Vacuum units for profile extrusion

## *BluSystems from Speck Pumpen*

### **Reduced energy consumption**

Renowned manufacturers of window profiles confirm: Compared with a conventional vacuum pump, BluSystems vacuum units save between 60 % and 90 % of the energy consumption.

The enormous saving is achieved through the leakage-air free and demand-based vacuum generation based on constant pressure measurement and speed regulation of the electric motors.

### **Simple installation**

BluSystems has a modular design and includes different types of vacuum units in various sizes. Parallel operation with conventional vacuum pumps and other systems is no problem at all.

Thanks to the decentralised concept, users can upgrade their existing extrusion lines easily without extensive and costly conversion work. Existing pumps or systems can be replaced with BluVac or BluLine vacuum units.

For plant manufacturers, interfaces are also available for PLC controls and BluVac vacuum units as so-called cartridge inserts without separators.

### **Easy operation**

Set the vacuum on the operating panel and you're done. The control ensures that the pressure level is constantly maintained. The machine operator no longer needs to monitor the process for the most part.

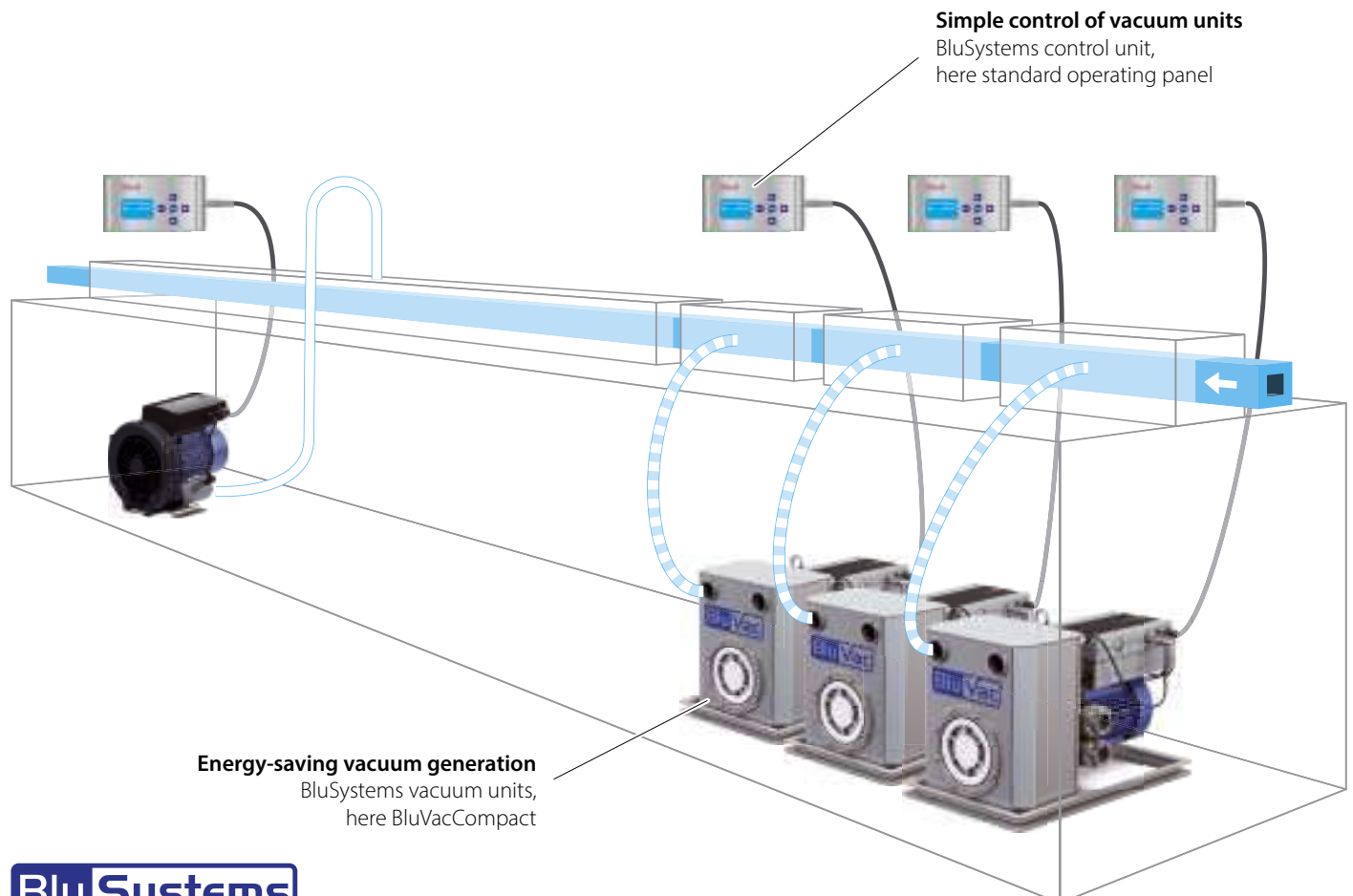

**Blu Systems**

# BluSystems – one system for a variety of applications

## Combine vacuum units to suit your requirements

Each profile has its own unique features - dry calibration, wet calibration. The need for different pressure levels and different suction volumes calls for specific solutions to ensure that the calibration table is optimally equipped.

With BluSystems from Speck, you can choose from four types of vacuum unit with different characteristics and in various sizes and find the best solution for your needs. If you want to use existing vacuum tanks in your calibration table, for example, the decentralized BluVacD vacuum unit is also available.



### BluVacCompact (BluVacC)

Type: VI-...-BVC  
Vacuum units with integrated separator, second generation in more compact design

Page 6

- » Extraction of air-water mixes
- » max. -930 mbar relative
- » max. 105 m<sup>3</sup>/h output
- » min. 6 m<sup>3</sup>/h water discharge



### BluLine

Type: VN-...-BL  
Vacuum units with vacuum pumps from the VN series

Page 8

- » Extraction of air with high levels of water
- » max. -930 mbar relative
- » max. 150 m<sup>3</sup>/h output
- » max. 4 m<sup>3</sup>/h water discharge



### BluLine

Type: VG-...-BL  
Vacuum units with vacuum pumps from the VG series

Page 10

- » Extraction of air with low levels of water
- » max. -930 mbar relative
- » max. 145 m<sup>3</sup>/h output
- » max. 2.5 m<sup>3</sup>/h water discharge



### BluLine

Type: VB-...-BL  
Vacuum units with side channel compressors from the VB series

Page 12

- » Extraction of moist air
- » max. -260 mbar relative
- » max. 500 m<sup>3</sup>/h output



### BluVacDezentral (BluVacD)

Decentralized vacuum units for plant-side separators  
Combination of vacuum pump/side channel compressor and a discharge pump  
Page 14

- » Parallel extraction of air and water from a plant-side separator (e.g. vacuum tank) in the calibration table
- » max. 30 m<sup>3</sup>/h water discharge

# BluSystems control units

## Simple control of vacuum units



### Setting the vacuum

The machine operator sets the desired relative vacuum (setpoint value) on the control unit – the BluSystems control panel is shown here. The control ensures that the pressure level remains constant from this point (just / actual value).

### Three operating modes

The software offers three different operating modes depending on the process phase and requirements.

Manual mode is the mode for the start-up process with major pressure fluctuations and a high suction capacity requirement. The machine operator adapts the required suction volume to the motor frequency here via the manual setting.

If the required suction capacity drops and the fluctuations become lower at the end of the start-up process, the system is switched to automatic mode. The control now ensures that the pressure level is constantly maintained. The demand-based vacuum generation results in a significant energy saving.

The automatic mode with frequency control is a quality assurance function, which was developed in cooperation with users. The software detects sudden and unintentional air leakage or infiltrated air occurring during the running process (e.g. through holes in the profile) and reacts with a warning message and/or by switching to manual mode with constant motor speed.

### Additional software functions

- » Storage and display of operating and consumption data
- » Visual warning in the display and/or with warning lights in the event of malfunctions
- » Master-slave function when several vacuum units are connected at a pressure level.

Page 17 shows different connection options for control units and vacuum units.



### BluSystems operating panel – standard control unit

#### Properties

- » Direct display of actual and setpoint values, the actual and setpoint value can be set with just a few key operations
- » Up to 5 different vacuum units can be controlled with one control panel. Many users prefer one control panel per vacuum unit, however.
- » Simple and cost-effective

#### Display and operation

- » LCD display, 40 mm x 73 mm
- » Robust keys

#### Protection class

- » IP 65



### BluSystems PLC interface – interface for PLC controls

- » The solution for calibration table manufacturers with plant-side display and control equipment with PLC controls
- » Up to 8 vacuum units can be controlled with the software installed on the coupler
- » Profibus interface on board, more on request

#### Plant-side

- » IP 20



### BluSystems PLC panel with touchscreen and memory

- » Up to 15 pressure level combinations can be stored
- » Up to 8 different vacuum units can be controlled
- » Flashing warning light in the event of alarms and dry run

#### Robust industrial touchscreen, 118 mm x 90 mm

- » IP 65

# BluVacCompact

VI-...-BVC – vacuum units with integrated separator - second generation

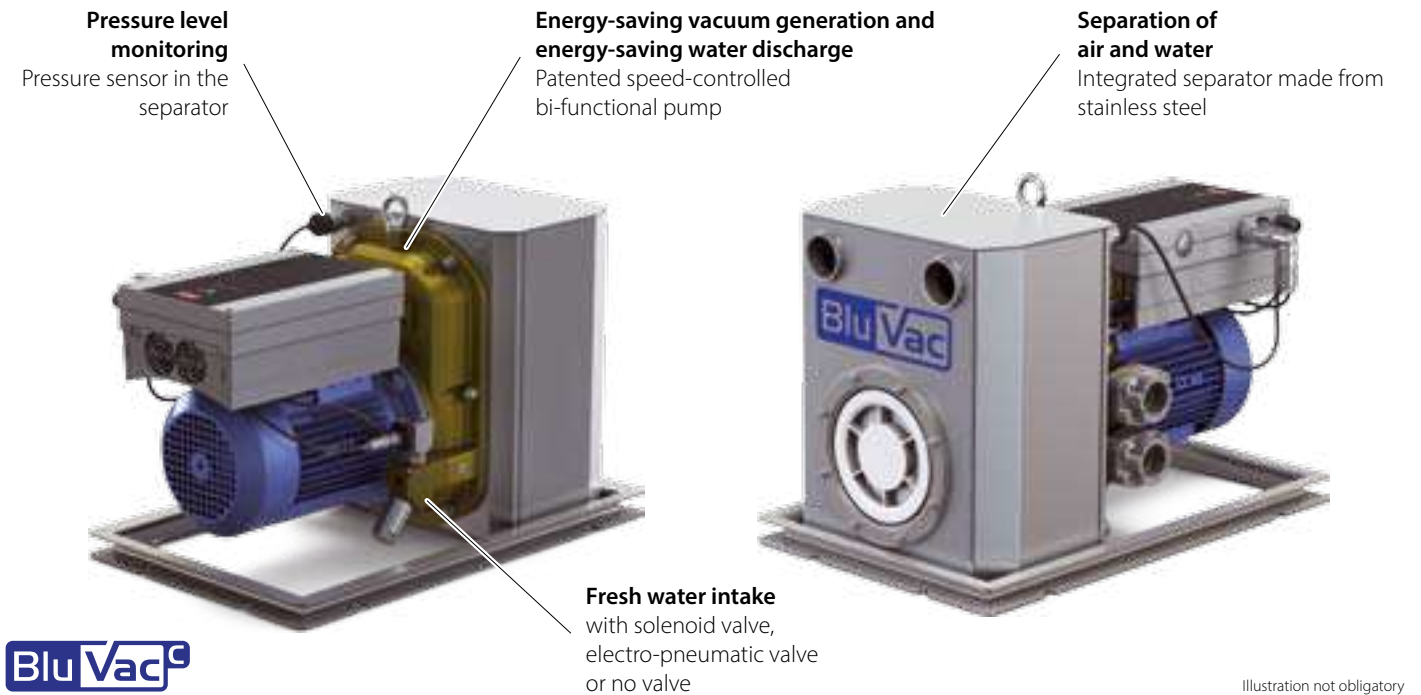

**BluVac<sup>®</sup>**

Illustration not obligatory

Type	max. relative vacuum	max. suction capacity	min. delivery of water
VI-55-BVC	-930 mbar	60 m <sup>3</sup> /h	6 m <sup>3</sup> /h
VI-130-BVC	-930 mbar	105 m <sup>3</sup> /h	6 m <sup>3</sup> /h

## Use

Extraction of air-water mixes

## General

BluVacCompact vacuum units are further developed, second generation vacuum units. They are much more compact and robust compared with the first generation, while offering the same performance.

The vacuum units with mechanical seals are available in rust-free materials and cast iron.

## Function

The machine operator sets the desired vacuum (setpoint) with the control unit. Air and water are discharged separately.

A pressure sensor in the separator above the water level constantly records the actual vacuum (actual value). Based on these pressure measurements, the frequency converter automatically regulates the set pressure level by adapting the motor speed.

The sensor-free regulation of the water level in the separator takes place via the special design of the bi-functional pump. The water discharge starts when the vacuum generation begins.

## The energy saving

The high energy saving is achieved through the demand-based vacuum generation. The cooling requirements for operating water are also reduced. Two sizes enable the system to be designed optimally to suit your suction volume requirements..

## Installation and retrofitting

BluVacCompact can replace existing water-bearing vacuum pumps (e.g. VN series) or conventional vacuum pumps.

BluVacCompact can also replace existing BluVac vacuum units from the first generation - the rail width, connections and capacity are identical.

The footprint is approximately the same as that of a conventional vacuum pump and installation is just as easy as with a vacuum pump.

## Control units

See page 5

## Fresh water supply

See page 16

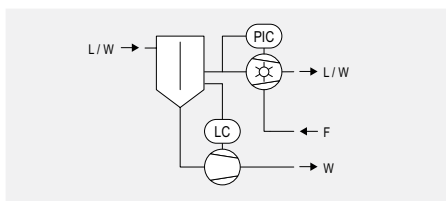

PIC **Pressure Indicate Control**  
Pressure display and control

LC **Liquid Control**  
Filling level control

L Air

W Water

F Operating / fresh water



## Dimensions and data

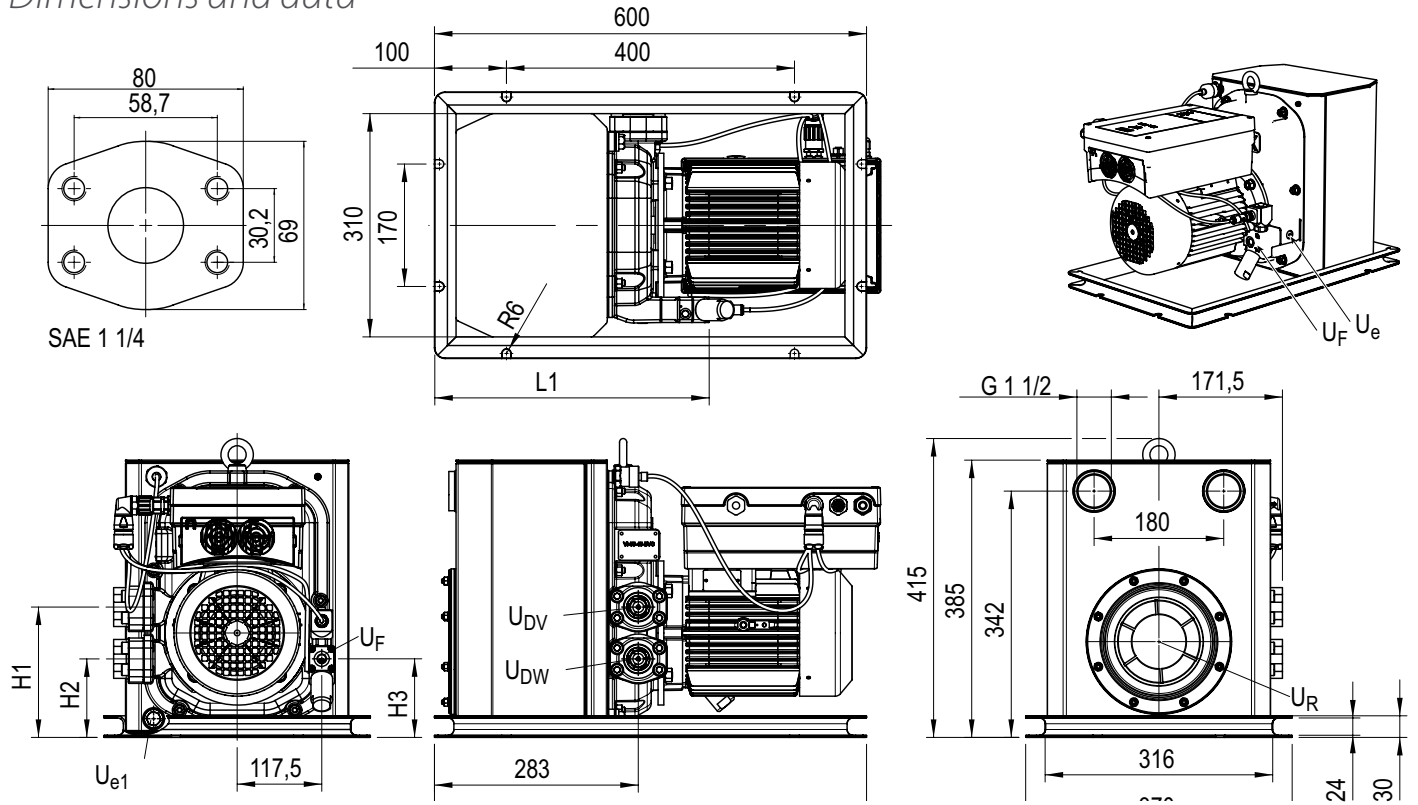

Type	Frame size	Dimensions					Weight	
		L1	L2	H1	H2	H3	kg	lbs
VI-55-BVC	90	381.5	580	181	109	109	67	148
VI-130-BVC	100	382.5	656	185	113	119	93	205

### Connections

$U_{DV}$	SAE 1 1/4	Pressure connection vacuum pump
$U_{DW}$	SAE 1 1/4	Pressure connection water discharge pump
$U_e$	G 1/8	Connection for drainage (drainage fresh liquid supply)
$U_{e1}$	G 1/2	Connection for drainage (drainage separator)
$U_F$	G 1/4	Connection for fresh liquid supply of the vacuum pump
$U_R$	Ø 121 mm	Inspection opening

# BluLine

*VN-...-BL – vacuum units with vacuum pumps from the VN series*

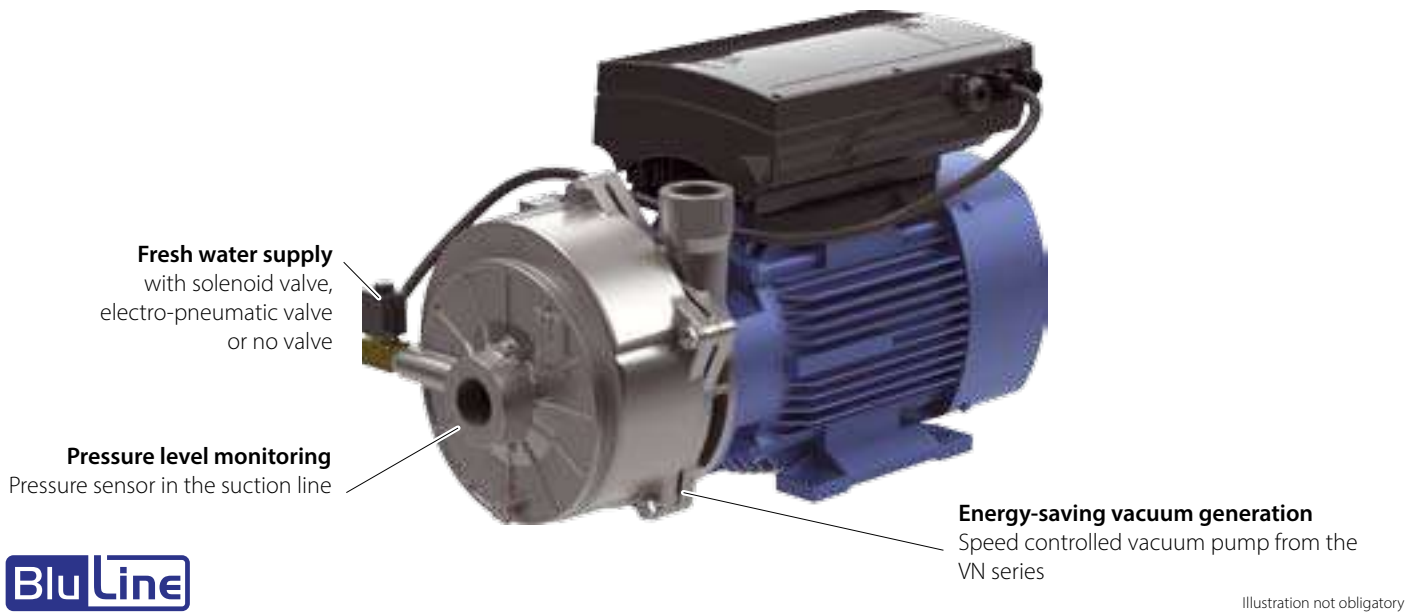

**BluLine**

Illustration not obligatory

Type	max. relative vacuum	max. suction capacity	max. delivery of water
VN-95-BL	-930 mbar	115 m <sup>3</sup> /h	4 m <sup>3</sup> /h
VN-125-BL	-930 mbar	150 m <sup>3</sup> /h	4 m <sup>3</sup> /h

## Use

Extraction of air with high levels of water

## General

The reliable VN type pumps are patented single-stage pumps with hub control. The vacuum units with mechanical seals are available in cast iron or stainless steel.

## Function

The hub control with valve flaps enables water to be pumped in much higher quantities compared with a conventional vacuum pump.

The machine operator sets the desired vacuum (setpoint) with the control unit. A pressure sensor in the suction line constantly records the vacuum (actual value). Based on these pressure measurements, the frequency converter automatically regulates the set pressure level by adapting the motor speed.

The water discharge in this case is always connected with the vacuum generation.

## The energy saving

The energy saving is achieved through the demand-based vacuum generation. The cooling requirements for operating water are also reduced.

Two sizes with four motor rated powers enable the system to be designed optimally to suit your suction volume requirements.

## Installation and retrofitting

BluLine vacuum units with VN type vacuum pumps can replace existing comparable vacuum pumps.

The supplied pressure sensor is installed on the suction line.

Existing uncontrolled VN type pumps can be upgraded to BluLine designs providing the motor is suitable.

## Control units

See page 5

## Fresh water supply

See page 16

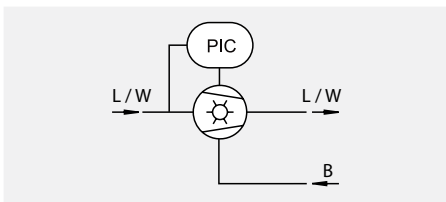

PIC Pressure Indicate Control  
Pressure display and control

L Air

W Water

B Operating / fresh water



## Dimensions and data

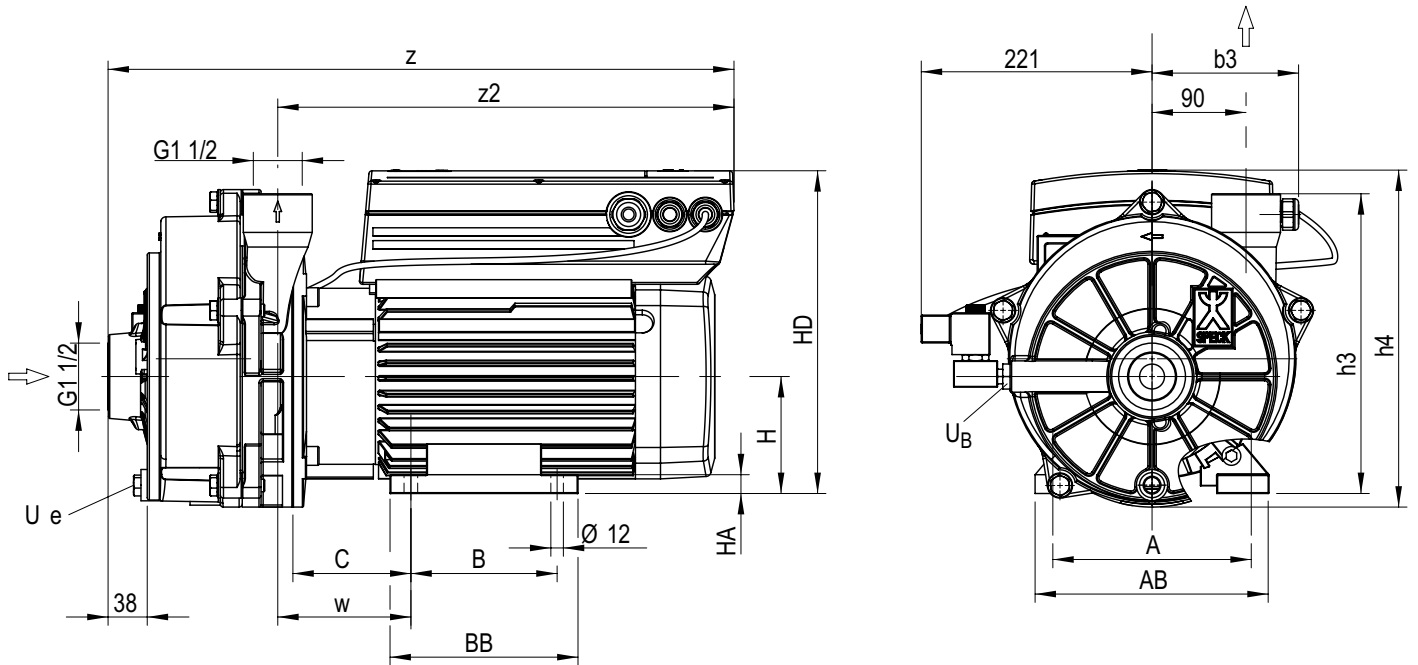

Type	Frame size	Dimensions														Connections		Weight		
		A	AB	B	BB	C	H	HA	HD	b3	h3	h4	u2	w	z	z2	$U_B$	$U_e$	kg	lbs
VN-95-BL	100	160	194	140	176	63	100	13	311	125	275	336	175	78	514	350	G1/2	G3/8	90	200
VN-95-BL	112	190	224	140	180	113	112	18	309	141	287	322	175	128	598	436	G1/2	G3/8	93	205
VN-125-BL	112	190	224	140	180	113	112	18	309	141	287	322	175	128	618	436	G1/2	G3/8	93	205
VN-125-BL	132	216	256	178	218	116	132	16	390	141	307	383	175	131	603	421	G1/2	G3/8	142	313

### Connections

$U_B$	Connection for operating liquid
$U_e$	Connection for drainage (screw plug)

# BluLine

VG...-BL – vacuum units with vacuum pumps from the VG series



**BluLine**

Illustration not obligatory

Type	max. relative vacuum	max. suction capacity	max. delivery of water
VG-30-BL	-930 mbar	34 m <sup>3</sup> /h	0.4 m <sup>3</sup> /h
VG-55-BL	-930 mbar	57 m <sup>3</sup> /h	0.4 m <sup>3</sup> /h
VG-95-BL	-930 mbar	82 m <sup>3</sup> /h	2.2 m <sup>3</sup> /h
VG-130-BL	-930 mbar	120 m <sup>3</sup> /h	2.4 m <sup>3</sup> /h
VG-155-BL	-960 mbar	146 m <sup>3</sup> /h	2.5 m <sup>3</sup> /h

## Use

Extraction of air with low levels of water or no water

## General

The tried-and-tested VG type single-stage pumps are extremely low-maintenance due to the valve-free design with no dead space. The vacuum units with mechanical seals are available in cast iron or stainless steel.

## Function

The machine operator sets the desired vacuum (setpoint) with the control unit. A pressure sensor in the suction nozzle constantly records the vacuum (actual value).

Based on these pressure measurements, the frequency converter automatically regulates the pressure level set by the machine operator by adapting the motor speed.

The water discharge in this case is always connected with the vacuum generation.

## The energy saving

The energy saving is achieved through the demand-based vacuum generation. The cooling requirements for operating water are also reduced.

Five sizes with six motor rated powers enable the system to be designed optimally to suit your suction volume requirements.

## Installation and retrofitting

BluLine vacuum units with VG type vacuum pumps can replace existing comparable vacuum pumps.

Existing uncontrolled VG type pumps can be upgraded to BluLine designs providing the motor is suitable.

## Control units

See page 5

## Fresh water supply

See page 16

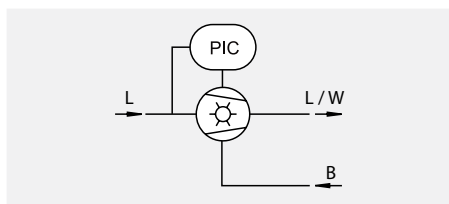

PIC Pressure Indicate Control  
Pressure display and control

L Air

W Water

B Operating / fresh water

## Dimensions and data

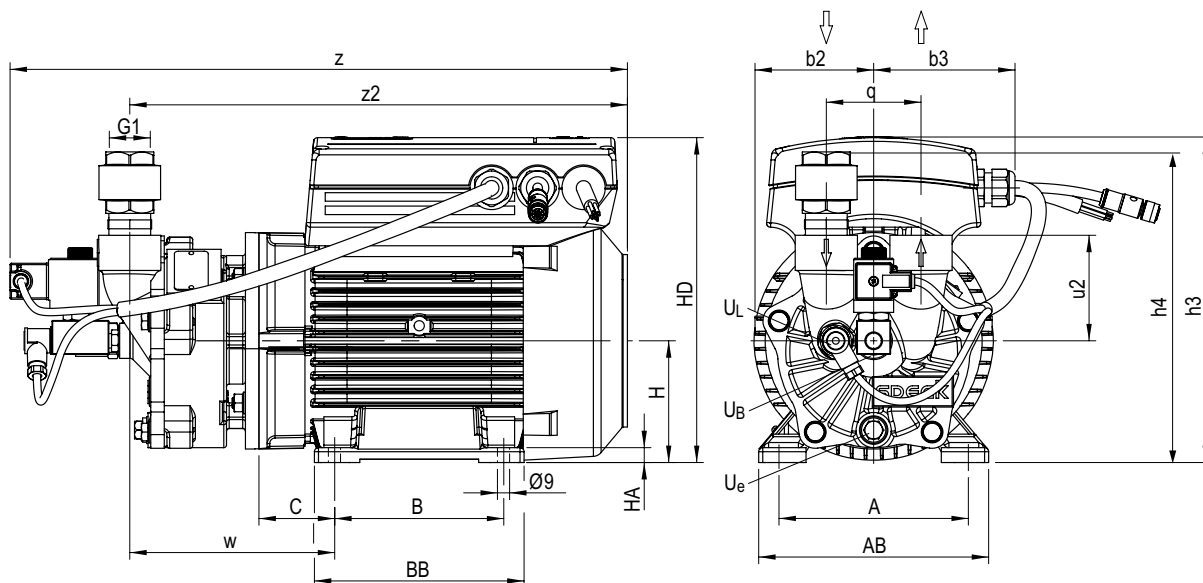

Type	FS	Dimensions																Connections			Weight		
		A	AB	B	BB	C	H	HA	HD	b2	b3	h3	h4	q	u2	w	z	z2	U <sub>B</sub>	U <sub>e</sub>	U <sub>L</sub>	kg	lbs
VG-30-BL	90	139	170	124	155	56	90	11	241	88	104	241	260	70	78	152	455	367	G1/4	G1/4	G1/4	27	60
VG-55-BL	100	159	195	134	176	63	100	13	267	98	113	267	273	74	81	175	514	415	G1/4	G1/4	G1/4	36	79

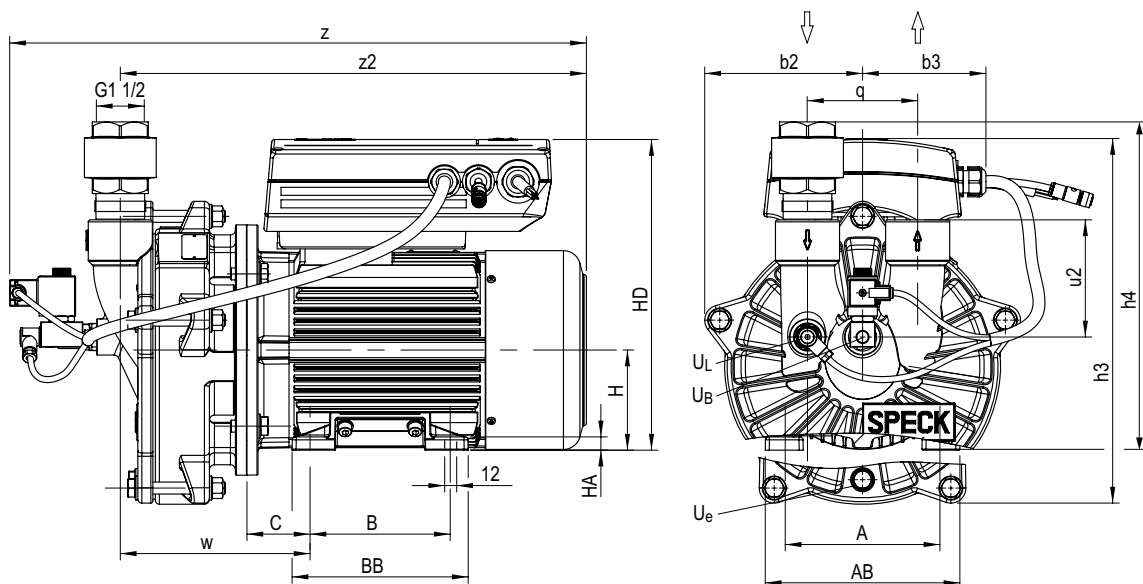

Type	FS	Dimensions																Connections			Weight		
		A	AB	B	BB	C	H	HA	HD	b2	b3	h3	h4	q	u2	w	z	z2	U <sub>B</sub>	U <sub>e</sub>	U <sub>L</sub>	kg	lbs
VG-95-BL	100	160	194	140	176	63	100	13	311	157	125	363	330	110	117	189	573	461	G1/2	G3/8	G1/2	73	160
VG-130-BL	100	160	194	140	176	63	100	13	311	157	125	363	330	110	117	198	582	493	G1/2	G3/8	G1/2	82	181
VG-130-BL	112	190	224	140	180	113	112	18	309	157	141	349	330	110	117	248	666	557	G1/2	G3/8	G1/2	88	194
VG-155-BL	112	190	224	140	180	113	112	18	309	157	141	349	342	110	117	265	679	573	G1/2	G3/8	G1/2	95	209

### Connections

- U<sub>B</sub> Connection for operating liquid
- U<sub>e</sub> Connection for drainage (screw plug)
- U<sub>L</sub> Connection for ventilation valve

# BluLine

*VB-...-BL – Vacuum units with side channel compressors from the VB series*



**Moisture-optimized bearing area**

Significantly longer service life than conventional side channel compressors

**Energy-saving vacuum generation**

Speed-controlled side channel compressor from the VB series

**Pressure level monitoring**

Pressure sensor in the suction connection

**BluLine**

Illustration not obligatory

Type	max. relative vacuum	max. suction capacity
VB-140-BL	-210 mbar	170 m <sup>3</sup> /h
VB-210-BL	-260 mbar	255 m <sup>3</sup> /h
VB-415-BL	-260 mbar	500 m <sup>3</sup> /h

**Use**

Extraction of moist air

**General**

Side channel compressors from the VB series are optimized in the bearing area for moist operating conditions. This means that they achieve a higher service life compared with conventional side channel compressors. The side channel compressors with rotary shaft seal are available in die-cast aluminium with an anti-corrosion coating on all parts which come into contact with media.

**Function**

The machine operator sets the desired vacuum (setpoint) with the control unit. A pressure sensor in the suction nozzle constantly records the vacuum (actual value).

Based on these pressure measurements, the frequency converter automatically regulates the pressure level set by the machine operator by adapting the motor speed.

**The energy saving**

The energy saving is achieved through the demand-based vacuum generation.

Three sizes enable optimal design to suit the supply demands.

**Installation and retrofitting**

BluLine vacuum units with VB type side channel compressors can replace existing comparable side channel compressors.

Existing uncontrolled VB type side channel compressors can be upgraded to BluLine designs providing the motor is suitable.

**Control units**

See page 5

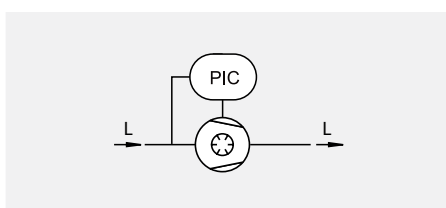

PIC Pressure Indicate Control  
Pressure display and control

L Air

### Dimensions and data

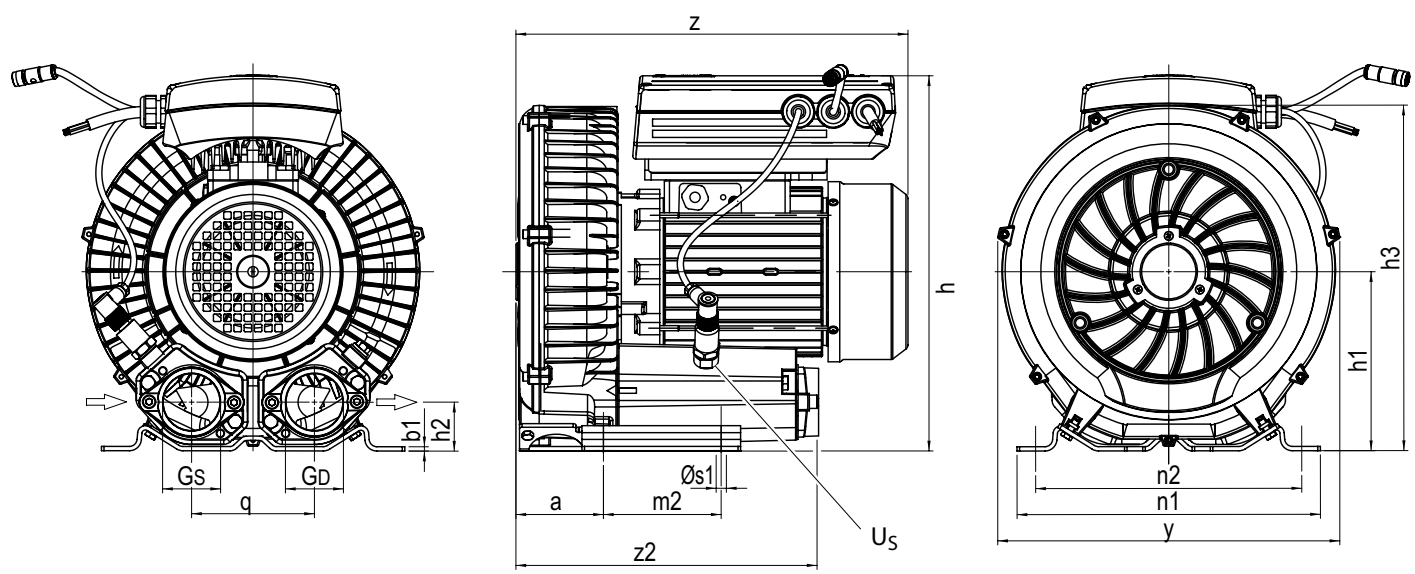

Type	Frame size	Dimensions														Connections		Weight	
		a	b1	h	h1	h2	h3	m2	n1	n2	q	s1	y	z	z2	G <sub>S</sub>	G <sub>D</sub>	kg	lbs
VB-140-BL	80	75	3	330	154	47	302	95	255	225	115	12	287	341	240	G1 1/2	G1 1/2	25	55
VB-210-BL	90	87	4	367	175	48	337	115	295	260	120	14	334	383	294	G2	G2	35	77
VB-415-BL	100	118	5	407	195	51	379	140	325	290	125	15	381	486	362	G2	G2	55	121

# BluVacD

## Decentralized vacuum units for plant-side separators

### Energy-saving vacuum generation

Speed-controlled vacuum pump

or

speed-controlled side channel compressor



### Energy-saving water discharge

Speed-controlled discharge pump from the ME-...-BVD series



**BluVacD**

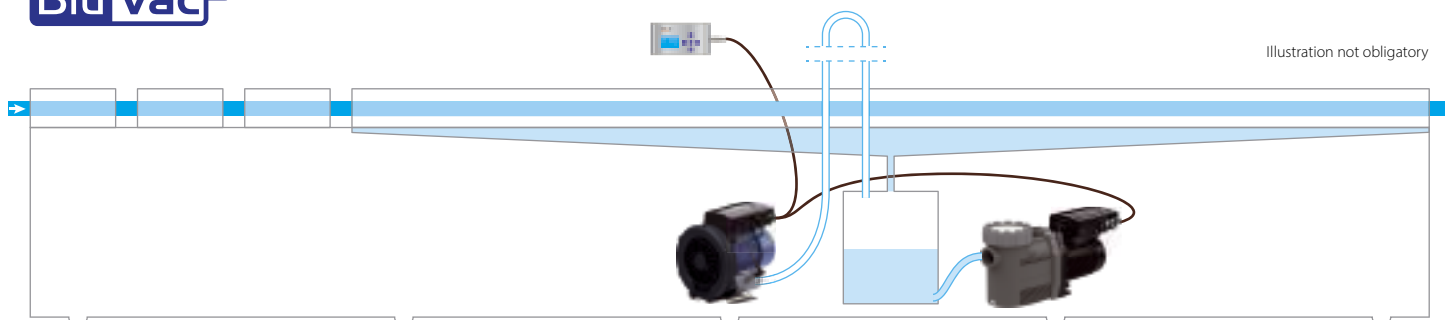

Type	
VB-...-BVD	Performance data as VB-...-BL, see page 12
VG-...-BVD	Performance data as VG-...-BL, see page 10

Type	Control range	max. total head	max. delivery of water
ME-125-BVD	0 – 60 Hz	28.0 m	10.2 m <sup>3</sup> /h
ME-90-15-BVD	0 – 60 Hz	22.4 m	26.4 m <sup>3</sup> /h
ME-90-20-BVD	0 – 60 Hz	25.0 m	30.3 m <sup>3</sup> /h

### Use

Extraction of air and water from a plant-side separator (e.g. vacuum tank) in the calibration table

### General

The vacuum is generated with type VG-...-BVD vacuum pumps or with a type VB-...-BVD side channel compressor depending on the required pressure level.

The water discharge takes place with type ME-...-BVD water pumps.

The water pumps with mechanical seal are available in rust-free plastic design.

### Function

Both pumps are connected with a data cable and controlled with a control unit.

The machine operator sets the desired vacuum (setpoint) with the control unit. The pressure control takes place based on continuous pressure measurements (actual value) and the adaptation of the motor speeds.

The water level control in the plant-side separator or vacuum tank takes place based on a hydrostatic filling level measurement in the vacuum tank.

The frequency converter controls the filling

level automatically based on these measurements by adapting the motor speed of the discharge pump. The water discharge takes place independently from the vacuum generation.

### The energy saving

The energy saving is achieved with the demand-based vacuum generation and the demand-based water discharge based on pressure measurements.

The different sizes of vacuum pumps, side channel compressors and water pumps available enable the system to be optimally designed to suit your suction volume and water delivery requirements.

### Installation and retrofitting

The decentralised vacuum units can be retrofitted easily. Piping and mounting the fill level sensor is simple.

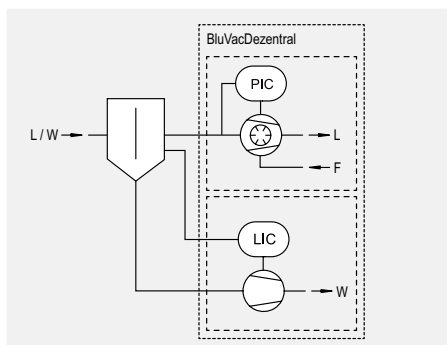

PIC **P**ressure **I**ndicate **C**ontrol  
Pressure display and control

LIC **L**iquid **I**ndicate **C**ontrol  
Filling level display and control

L Air

W Water

F Operating / fresh water



### Dimensions and data

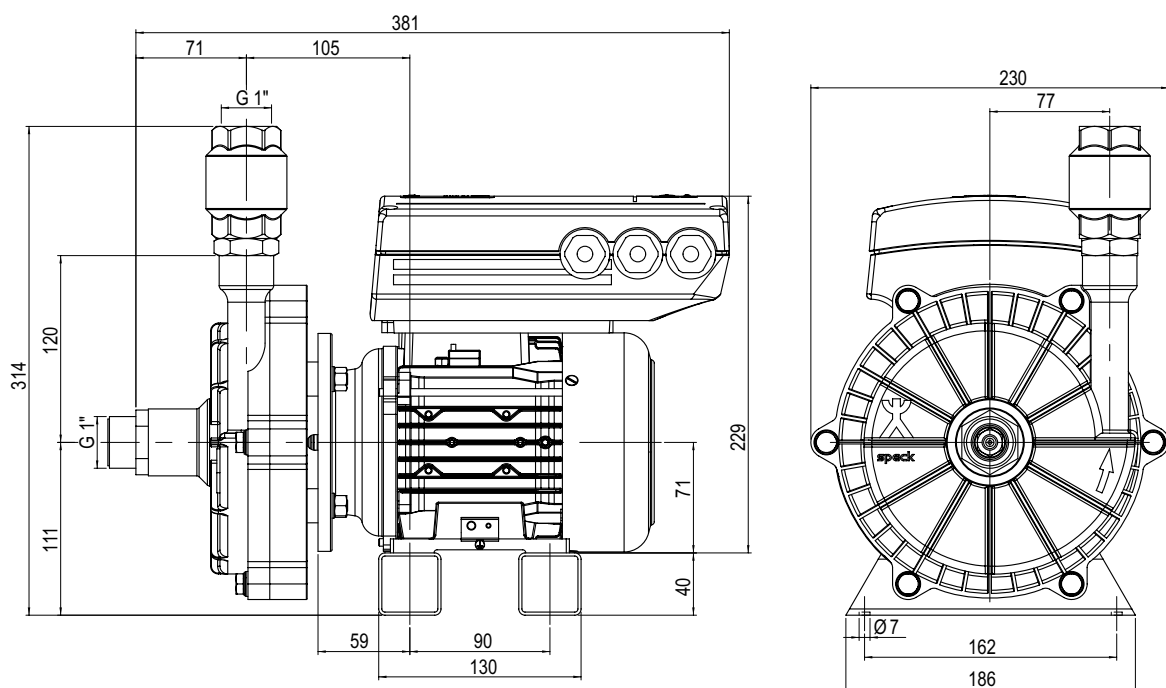

	Frame size	Weight	
		kg	lbs
ME-125-BVD	71	11	24

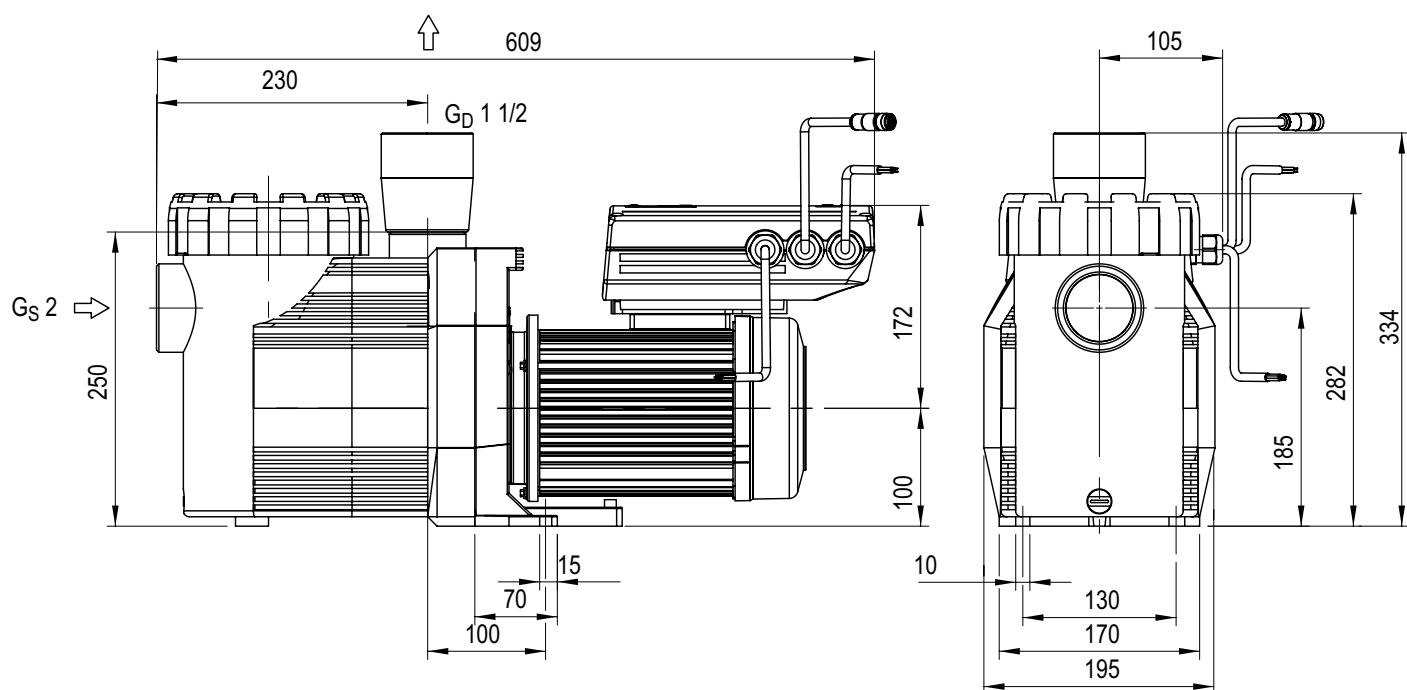

	Weight	
	kg	lbs
ME-90-15-BVD	25	55
ME-90-20-BVD	25	55

# Fresh water supply

## Three options for vacuum units with vacuum pumps

### Fresh water supply with pressurised water and valves

The fresh water supply with pressurised water and valves guarantees optimal accuracy during vacuum control, as the entered fresh water quantity always remains constant.

After the vacuum unit is started, the valve on the fresh water connection opens automatically at the same time and supplies the pump with fresh water.

An optional flow sensor protects the vacuum unit from damage if a problem-free fresh water supply cannot be guaranteed. This is the case, for example, with a water supply without or with inadequate pressure boosting systems and / or with pressure fluctuations.

If the fresh water intake is insufficient or if the fresh water intake fails, the software stops the vacuum unit and prevents the mechanical seal from running dry.

For problem-free operation, it has also proven to be beneficial to install a filter before the valve with a mesh size of 300, which is maintained regularly.

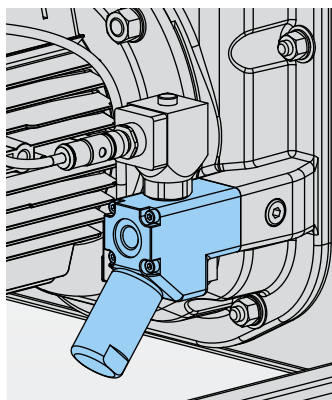

Electro-pneumatic valve

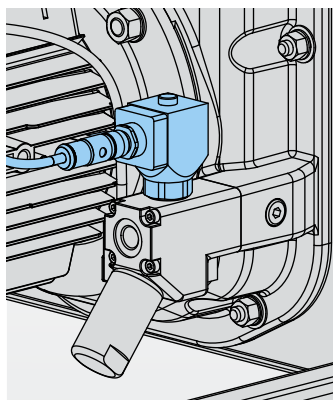

Optional flow sensor with electro-pneumatic valve

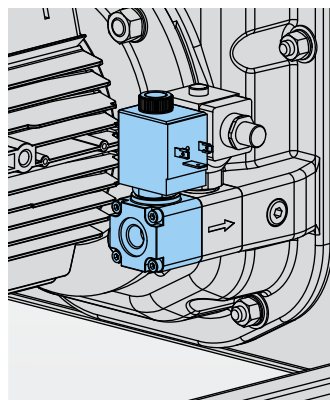

Solenoid valve

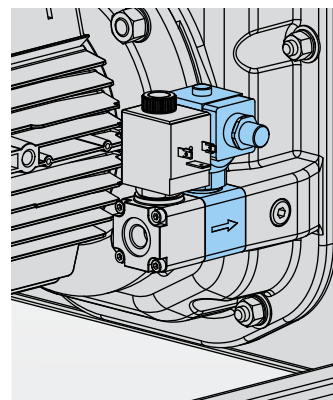

Optional flow sensor with solenoid valve

### Valve types

Type / Water pressure	Electro-pneumatic valve 2 – 6 bar	Solenoid valves - two versions 2 – 6 bar	0.5 – 2 bar
Fresh water quality	low contamination	no contamination	no contamination
Pressurised air connection	3.5 – 8 bar	–	–
Filter (300 µm) before valve	recommended	highly recommended	highly recommended
Flow sensor	optional / recommended	optional / recommended	optional / recommended
Power supply	24 V	230 V	230 V

### Valve-free fresh water supply from controlled liquid supply

The fresh water supply with controlled liquid supply is standard with conventional vacuum pumps in industrial systems. It is suitable for processes where the relative vacuum level is at least -250 mbar.

The vacuum pump takes its fresh water automatically from a water vessel, with a level 300 mm above the centre of the shaft.

### Valve-free fresh water supply with process water

Due to their design, liquid ring vacuum pumps are able to take their fresh water from the process water.

This fresh water supply uses simple equipment and is suitable for plants and processes requiring reliable, uninterrupted process water in sufficient quantities.

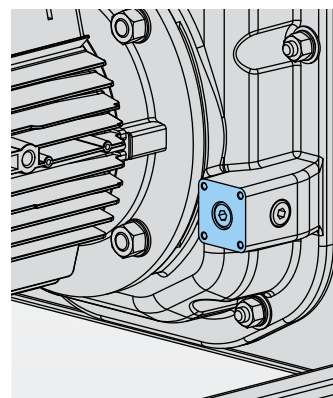

Valve-free design

# Installation examples

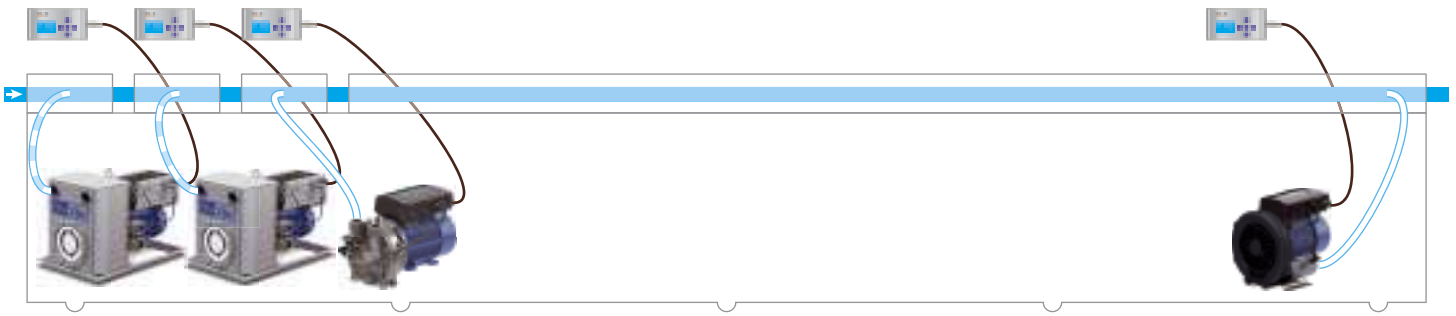

Installation example for one operating panel per vacuum unit

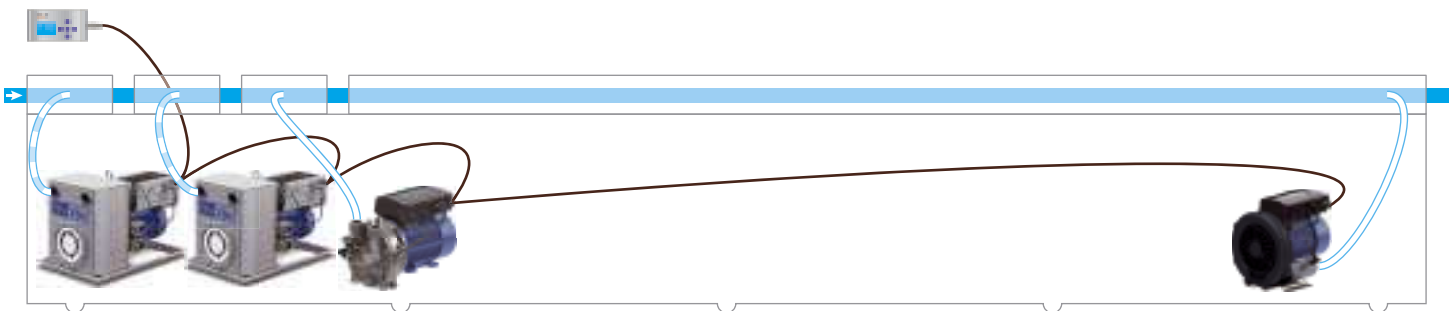

Installation example for controlling multiple vacuum units with one operating panel

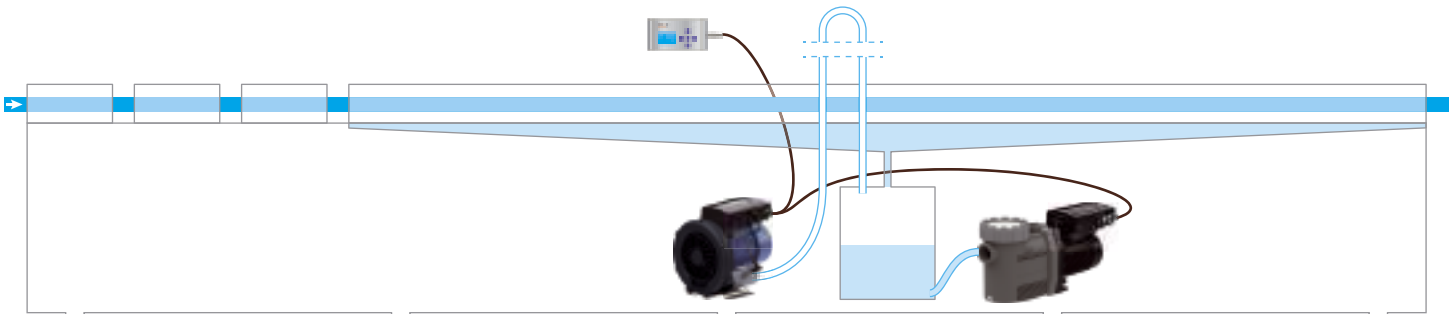

Installation example of a decentralised vacuum unit for plant-side separators (vacuum tanks) - here with side channel compressor

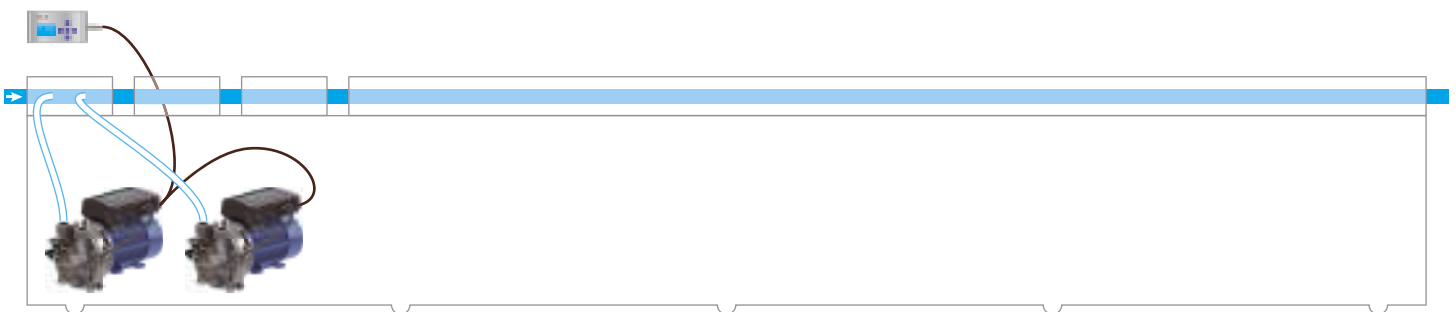

Installation example for controlling a pressure level with two vacuum units via the software function master slave

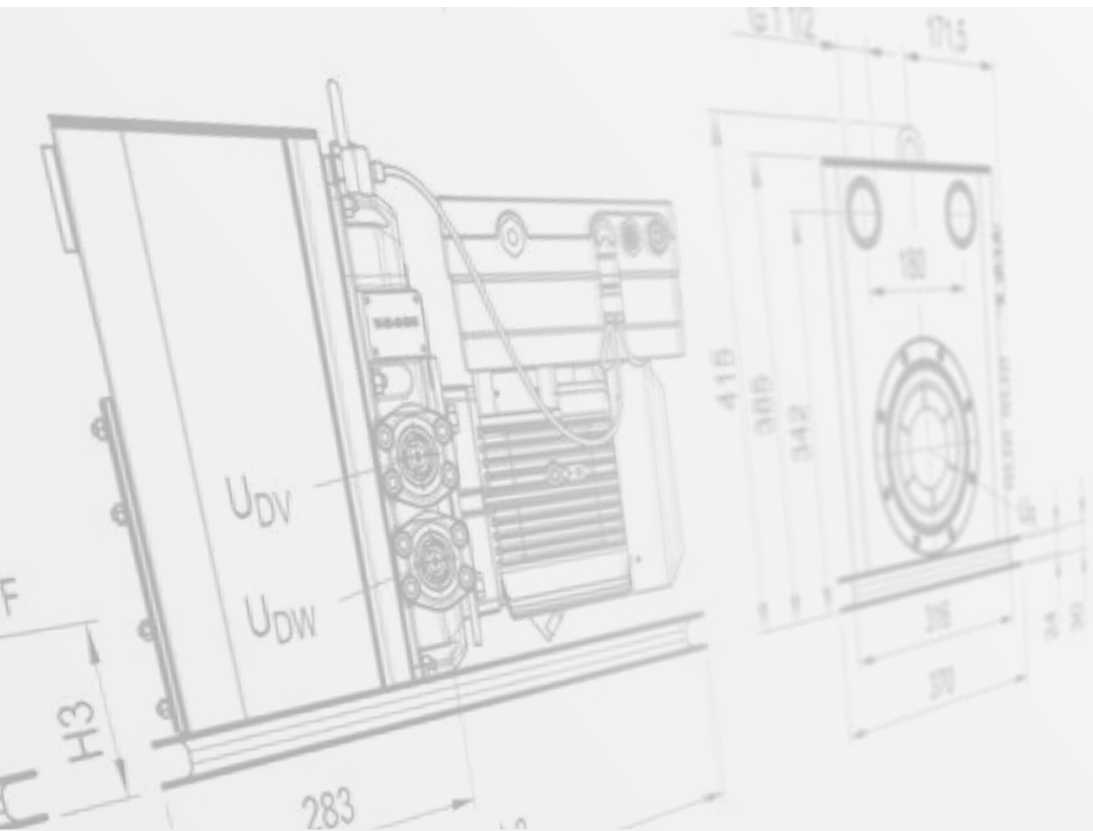

## Representation

**SPECK X**  
pumps

Speck Pumps  
8125 Bayberry Rd  
Jacksonville, FL 32256 USA  
Tel: 904-739-2626  
Fax: 904-737-5261

website: [usa.speck-pumps.com](http://usa.speck-pumps.com)  
email: [info.usa@speck-pumps.com](mailto:info.usa@speck-pumps.com)

**speck** |

Speck Pumpen Vakuumtechnik GmbH & Co. KG  
Postfach 1453 · 91142 Roth / Germany  
Regensburger Ring 6-8 · 91154 Roth / Germany  
Tel.: +49 (0) 91 71 809 - 0  
Fax: +49 (0) 91 71 809 - 10