



The e-NSC End Suction Pump Series

Your go-to single-stage pump for heavy-duty use

STANDARDIZED TO EN733, ISO 5199 AND DIRECTIVE 2009/125/EC.
POTABLE WATER APPROVED (ACS AND DM174).

It's not your standard end suction pump

Built with the highest level of flexibility and modularity, the new Lowara e-NSC series is ideal for transport and a vast array of industrial applications. With efficiency levels that exceed ErP 2015, the e-NSC offers economical pumping solutions for the long term, and will be your go-to pump for all applications.

Design details

This single-stage, back pull-out, horizontal centrifugal pump is designed according to the EN733 standard for dimensions and power ratings, as well as the ISO 5199* standard for installation, maintenance, quality and safety. It's available in a block or closed coupled version, and in a frame-mounted version with a bearing bracket.

Functional coverage

The NSC pumps cover the following range:

- DN: 32-300
- Flow: Up to 1800m³/hr
- Head: Up to 160m
- Power: From 0.25kW to 355kW
- Pressure: PN16
- Temperature: Up to 140°C

Variable speed applications

By equipping the NSC with a HYDROVAR pump controller, the duty point remains exactly where it should be. This is significant; reducing the speed by 50% reduces the power consumption by 87.5%.

Motor information

- IE3 or higher rated motors
- F (155°C) insulation class
- Protection grade: IP55
- 50Hz and 60Hz voltages
- A wide range of motor options

Typical applications

- Water transport
- HVAC
- District energy
- Firefighting
- Greenhouse heating/cooling
- Desalination
- Aquaculture
- Power plant

Typical pumped fluids

- Drinking water
- Sea water and brine
- Brackish water
- Water with solvents
- Water with cleaning products
- Water with oil
- Swimming pool water
- Condensate



* for pump models 50-315, 65-315, 80-315, 80-316 and with DN>=100

Here's why it's so versatile and reliable



The e-NSC series guarantees power and efficiency to your applications

- Hydraulic and motor efficiency exceeding the European Ecodesign requirements
- Improved hydraulic coverage and performance
- Operation-related optimization of load management, thanks to versions equipped with Hydrovar

The e-NSC series addresses your process requirements

- Liquid temperatures from -25°C to 140°C
- Standard pressure of 16 bar over the entire range
- Low NPSH for improved open-loop applications
- Optimized space management with our compact configuration with motor (17% reduction)
- Wide configuration options: compact, block and frame-mounted designs
- Wide material options for casing and impeller, from bronze to super-duplex
- Wide mechanical seal options: from single unbalanced seals to double cartridge configurations, with a variety of materials to accommodate all pumped fluids
- Optional advanced bearing frame for heavier-duty applications



Acquire our know-how and support together with our pumps

- Pre- and post-sales support
- Dedicated resources for projects and contractors
- Selection software for fast and easy configuration
- Best-in-class lead times

Buy it and forget about it

- Easy maintenance and spare parts management (modular construction, back pull-out design)
- Improved reliability and extended pump life (robust construction, reduced stress on bearings)
- Standard wear rings which reduce wear and lower maintenance costs
- Reduced life cycle cost and optimized total ownership cost



See how it all comes together

Customer benefits

1 Casing

Rated at 16 bar and available in a large range of materials to accommodate a variety of pumped fluids. The casings, over the entire range, have a centerline discharge which minimizes turbulence and therefore ensures higher efficiency.

2 Impeller

Optimized hydraulics to guarantee efficiency higher than mandated by ErP and wider hydraulic coverage. Impellers are available in a large range of materials to accommodate all pumping needs.

3 Mechanical seal

Seal chamber designed according to EN12756 permits fast and easy seal changing, thus minimizing maintenance time. Rubber bellow-type seals offered as standard in different construction materials. Cartridge seals in single or dual configuration are offered as options.

4 Wear rings

Stainless steel or duplex casing wear rings are offered as standard on all pumps, which prevents wear of the casing and casing cover, lowering the maintenance costs.

5 Flange drilling

The flanges are drilled to EN1092 as standard, but can also be drilled according to ASME. This ensures that the e-NSC pumps can be installed in any system.

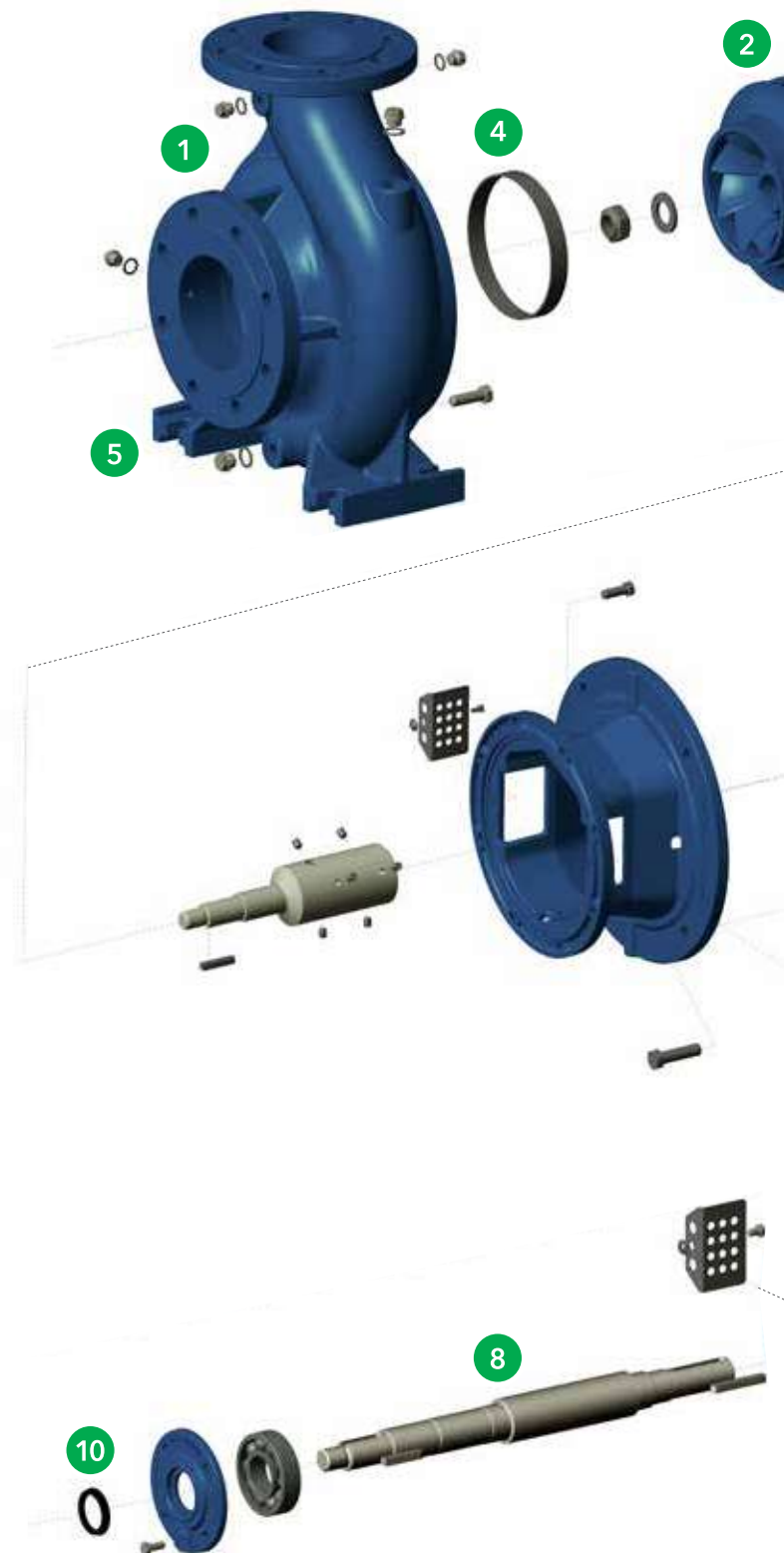



6 Motor efficiency

IE3 is the standard offering over the entire range, but higher efficiency levels of motors are available, further reducing operating costs.

7 Bearings

Deep-groove ball bearings on the standard bearing brackets ensure proper absorption of radial and axial forces. For the advanced bearing bracket configuration, dual row greasable/oil-lubricated bearings allow for even longer pump life.



8 Shaft

Standard high-performance shaft made of stainless steel; also available in duplex.

9 Bearing bracket

Standard and advanced bearing bracket options are available, for both standard and heavier-duty application requirements.

10 Bearing sealing

A lip seal (standard bearing bracket) or labyrinth seal (advanced bearing bracket) ensures no leaking.

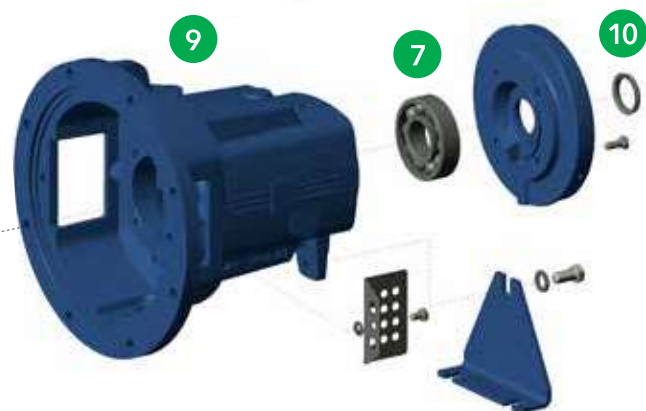

The compact, powerful NSCS

The NSCS is a single-stage horizontal volute casing pump with a back pull-out design, rigidly coupled to a standard motor.

Hydraulic coverage

The NSCS is available for the following range:

DN:	32-250
Flow:	Up to 1300m ³ /hr
Head:	Up to 160m
Power:	Up to 90kW

Typical applications

They include but are not limited to:

- Heating systems
- Small to medium chilled water systems
- Washing systems
- Irrigation

Advantages of construction

- Compact
- Easy maintenance



*Pictured base frame is optional.

2 pole | ~2900 rpm | ISO 9906:2012 - Grade 3B

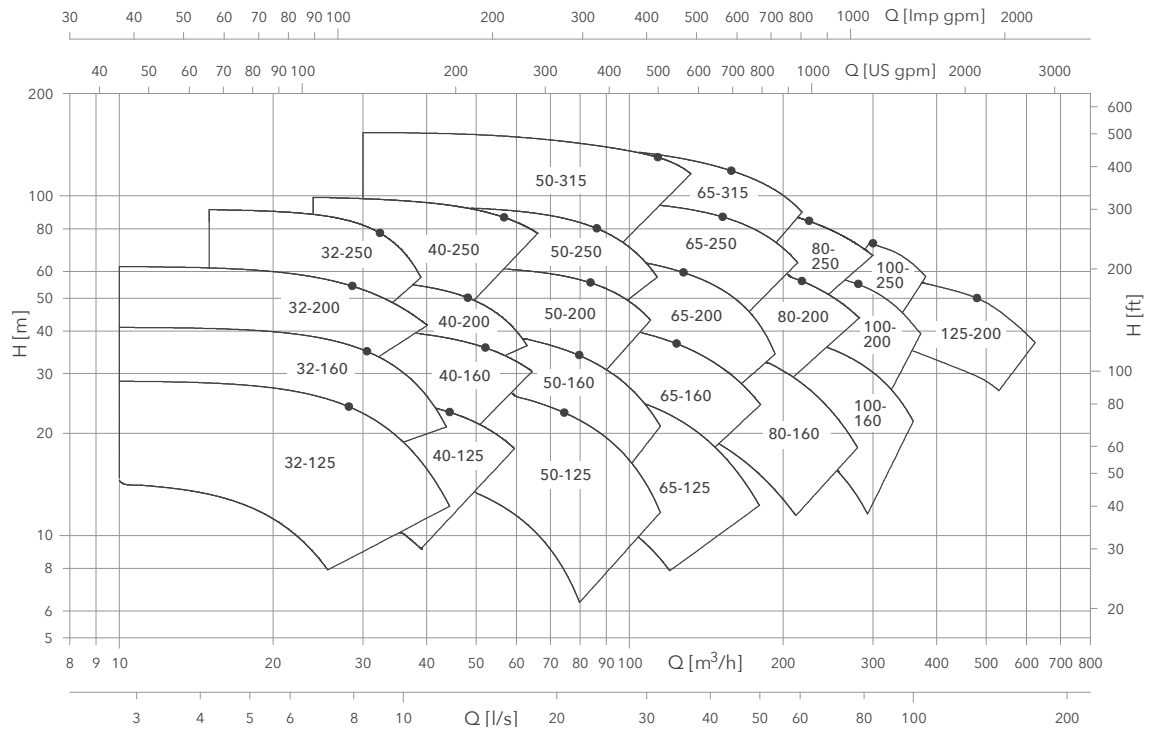

4 pole | ~1450 rpm | ISO 9906:2012 - Grade 3B

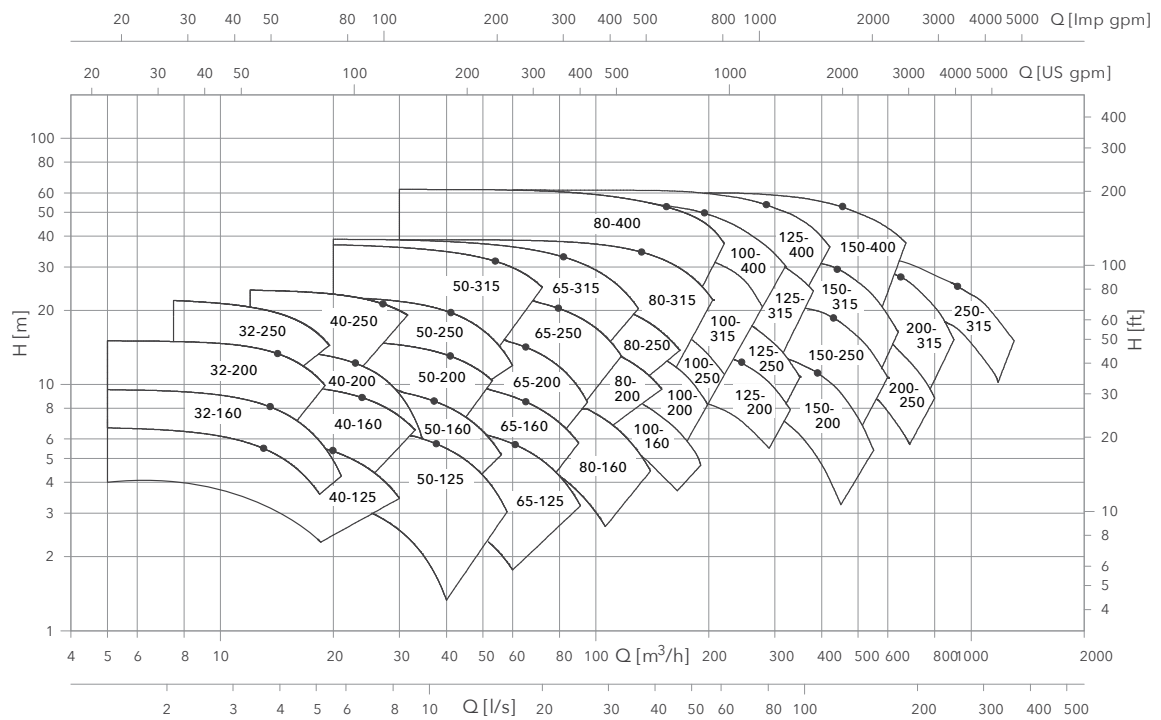

The rugged, robust NSCF/C

The NSCF/C is a single-stage horizontal volute casing pump with a back pull-out design, mounted on a frame. The hydraulics are coupled to the motor using a flexible coupling. The NSCC versions use a spacer coupling.

Hydraulic coverage

The NSCF/C is available for the following range:

DN:	32-300
Flow:	Up to 1800m ³ /hr
Head:	Up to 160m
Power:	Up to 355kW

Typical applications

They include but are not limited to:

- Water transport
- Firefighting
- Large chilled water systems
- Desalination plants
- Mining dust suppression

Advantages of construction

- Dedicated bearings on the power end
- Higher permissible flange forces
- Higher permissible suction pressure



2 pole | ~2900 rpm | ISO 9906:2012 - Grade 3B

■ Advanced bearing bracket optional

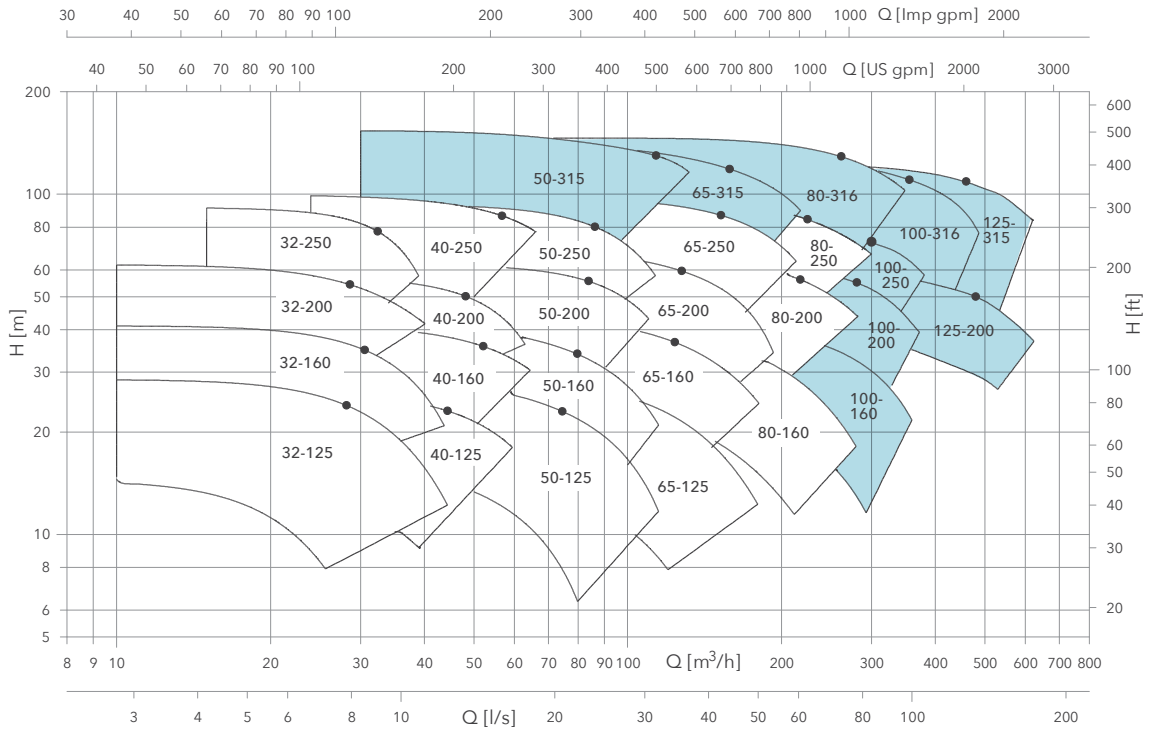

4 pole | ~1450 rpm | ISO 9906:2012 - Grade 3B

■ Advanced bearing bracket optional

■ Advanced bearing bracket standard

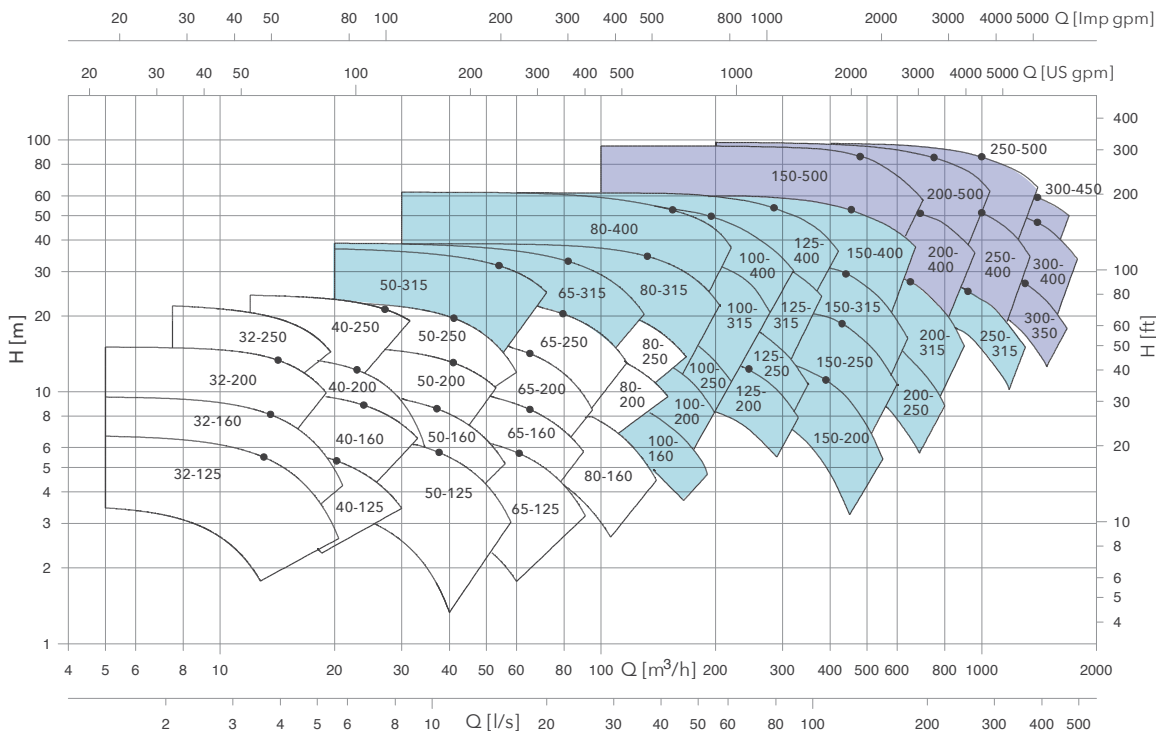

Capable of pumping any water-based fluid

Nomenclature

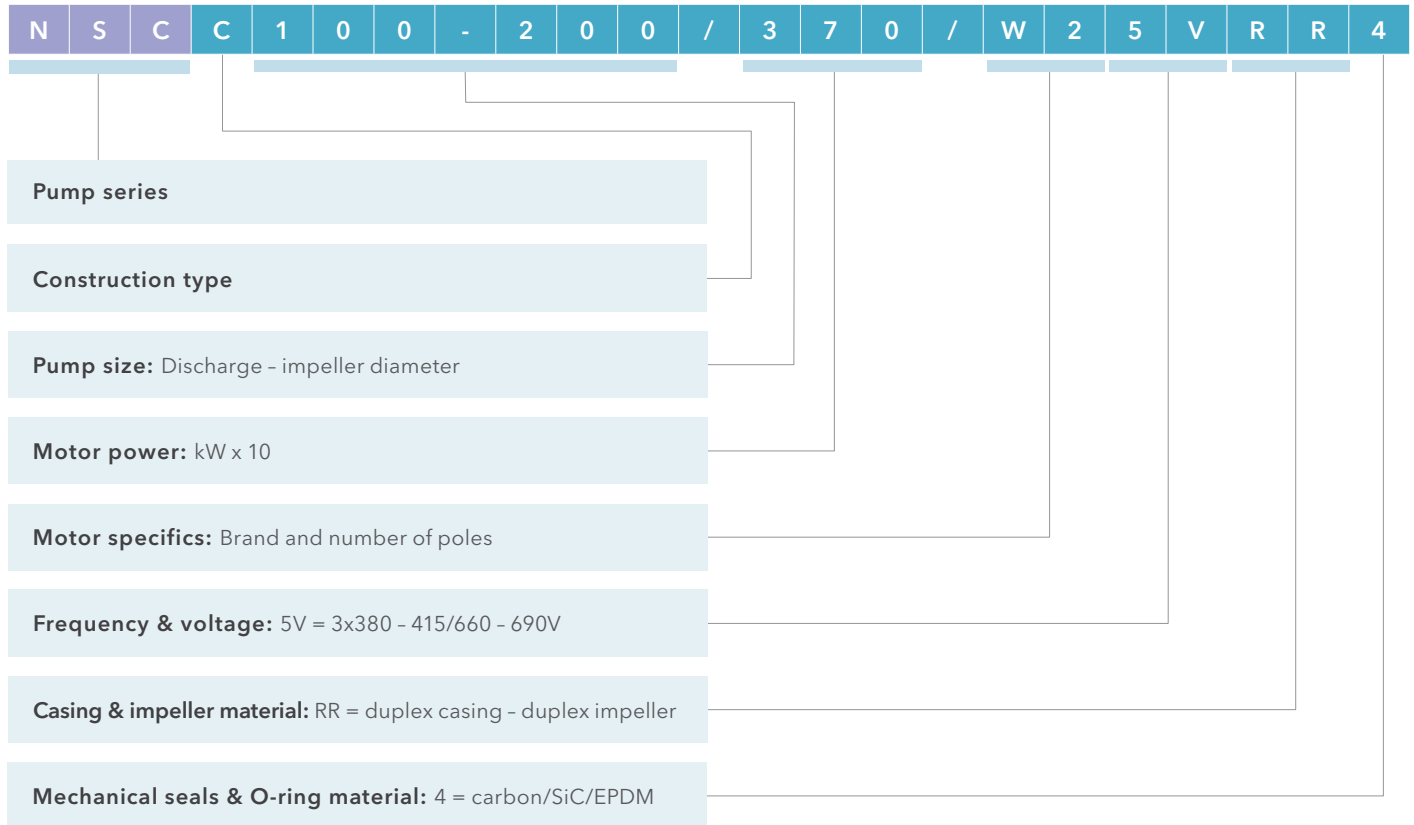

Material configuration per pump size

Various material configurations are available to fit the needs of different pumped mediums and application requirements. Below are the specifics regarding the material configurations and their availability for the different pump sizes.

	CS	CC/DC	CB/DB	CN/DN	NN/RN	RR
Casing	C	C/D			N/R	R
Impeller	S	C	B	N	N	
Casing cover	C	C/D			N/R	
Shaft	S1				N1	
Wear ring	S2 or N					N or N1
Motor adapter	C					

Shaft and wear rings in duplex are available as an option for all pump sizes. Other material configurations are available upon request.

Material availability per pump size

		Impeller size						
		125	160	200	250	315/316	400	500
Discharge size	32	CS	CS	CS	CS			
	40	CS	CS	CS	CS			
	50	CS	CS	CS	CS	CC-CB-CN NN-RR		
	65	CC-CB-CN NN-RR	CC-CB-CN NN-RR	CC-CB-CN NN-RR	CC-CB-CN NN-RR	CC-CB-CN NN-RR		
	80		CC-CB-CN NN-RR	CC-CB-CN NN-RR	CC-CB-CN NN-RR	CC-CB-CN NN-RR	CC-CB-CN NN-RR	
	100		CC-CB-CN NN-RR	CC-CB-CN NN-RR	CC-CB-CN NN-RR	CC-CB-CN NN-RR	CC-CB-CN NN-RR	
	125			CC-CB-CN NN-RR	CC-CB-CN NN-RR	CC-CB-CN NN-RR	CC-CB-CN NN-RR	
	150			CC-CB-CN NN-RR	CC-CB-CN NN-RR	CC-CB-CN NN-RR	CC-CB-CN NN-RR	DC-DB-DN RN-RR
	200				DC-DB-DN RN-RR	DC-DB-DN RN-RR	DC-DB-DN RN-RR	DC-DB-DN RN-RR
	250					DC-DB-DN RN-RR	DC-DB-DN RN-RR	DC-DB-DN RN-RR
	300					DC-DB-DN RN-RR	DC-DB-DN RN-RR	DC-DB-DN RN-RR

Reference standard

	MATERIAL	EUROPE	USA
C	Cast iron	EN 1561 - JL1040	ASTM - Class 35*
D	Ductile iron	EN 1563 - JS1030	ASTM - 65-45-12*
S	Stainless steel	EN 10088-1-X2CrNiMo17-12-2 (1.4404)	ASTM - 316L
S1	Stainless steel	EN 10088 - X17CrNi16-2 (1.4057)	ASTM - 431*
S2	Stainless steel	EN 10088 - X5CrNi18-10 (1.4301)	ASTM - 304N
N	Stainless steel	EN 10283 - GX 5 CrNiMo19-11-2 (1.4408)	ASTM - CF8M*
N1	Duplex	EN 10088 - X2CrNiMoN22-5-3 (1.4462)	ASTM - F51*
R	Duplex	EN 10283-4 - GX 2 CrNiMoCuN25-6-3-3 (1.4517)	ASTM - CD4MCuN*

*Or similar grade.

A bearing bracket adapted to your needs

Standard bearing bracket

1. Volute casing
2. Casing cover
3. Impeller
4. Shaft
5. Ball bearing
6. Bearing housing
7. Mechanical seal
8. Shaft sealing (lip seal)
9. Support foot

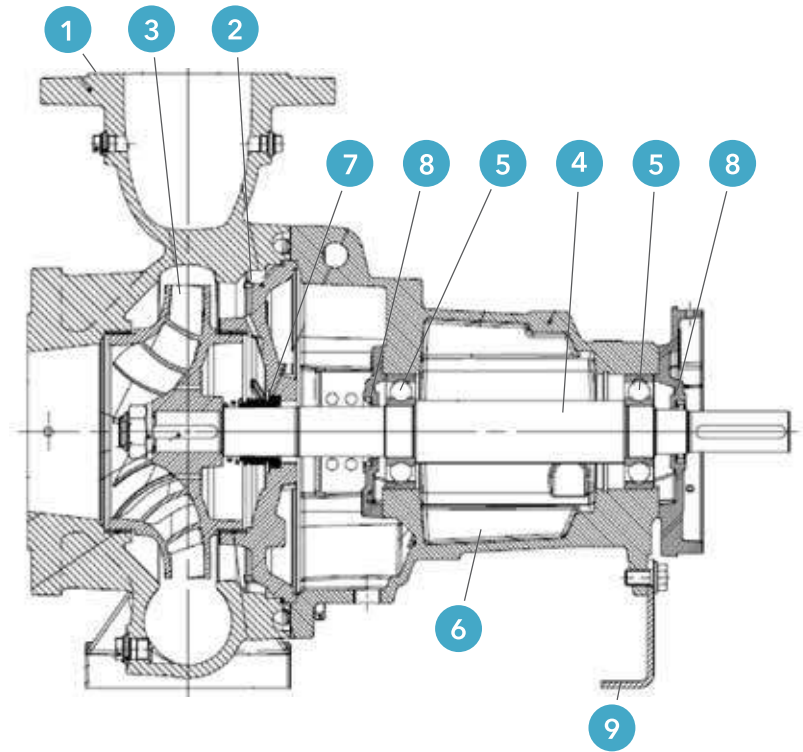

Advanced bearing bracket with oil lubrication

1. Volute casing
2. Casing cover
3. Impeller
4. Shaft
5. Ball bearing
- 5b. Double row ball bearing
6. Bearing housing
7. Mechanical seal
- 8b. Shaft sealing (labyrinth seal)
9. Support foot
10. Oil filling plug
11. Oil drain plug
12. Oil side glass

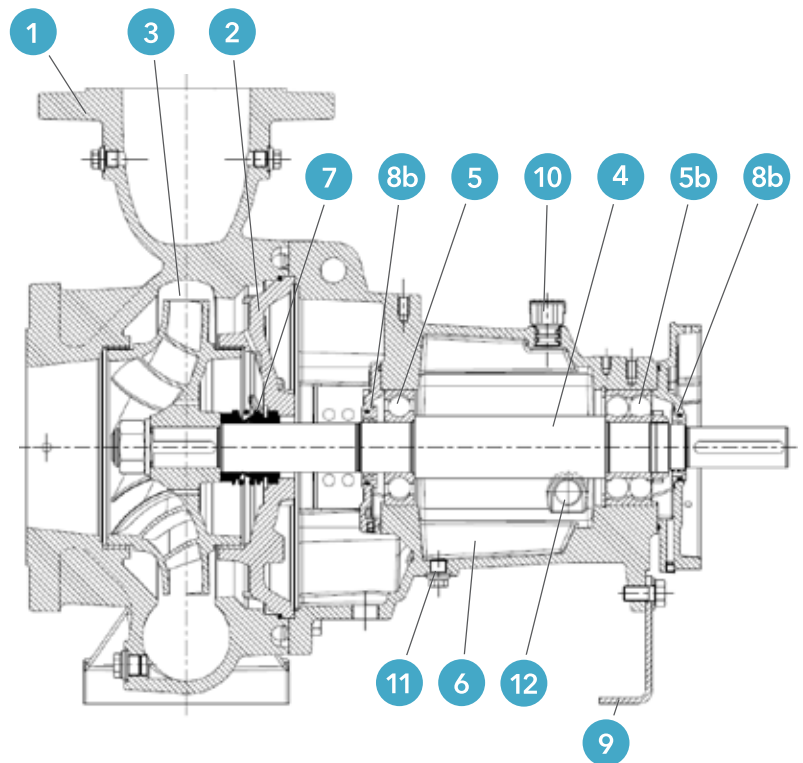

Advanced bearing bracket with grease lubrication

1. Volute casing
2. Casing cover
3. Impeller
4. Shaft
5. Ball bearing
- 5b. Double row ball bearing
6. Bearing housing
7. Mechanical seal
- 8b. Shaft sealing (labyrinth seal)
9. Support foot
13. Grease nipple

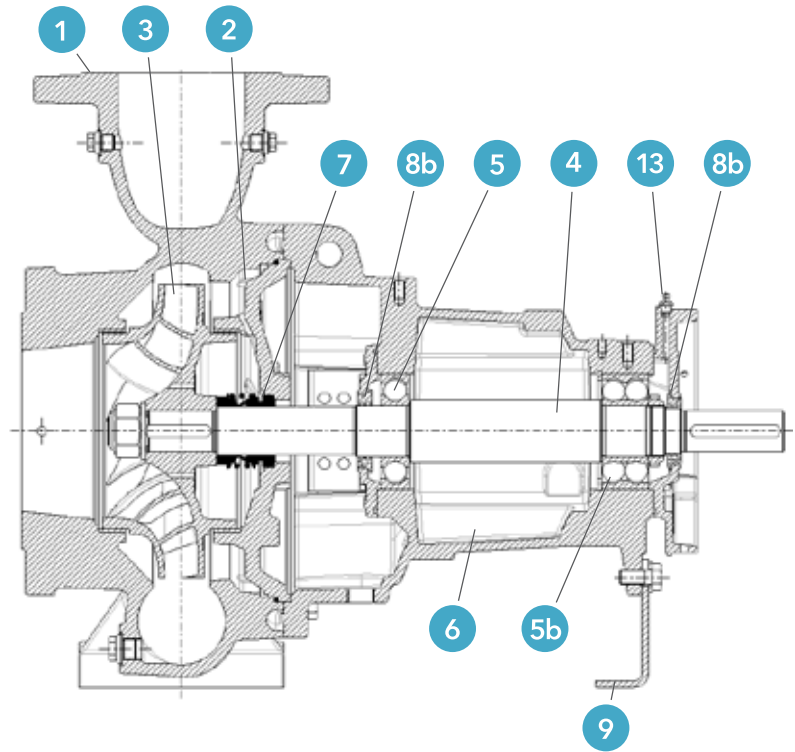

Bearing configuration

The standard bearing bracket design provides an L10 life (17,500 hours) specified by ISO 5199.

The advanced bearing bracket design provides a life in excess of the minimum L10, with 25,000 hours. The bearing configuration of the advanced bearing bracket is as follows:

- **Radial bearing:** Single-row, deep-groove ball bearing
- **Thrust bearing:** Double-row, angular contact bearing

Bearing lubrication

The following options are available:

- **Grease lubrication:** Grease nipples fitted on the pump allow for punctual relubrication. The use of grease instead of oil helps in reaching higher starting/running torques, but is recommended for lower running speeds.
- **Oil lubrication:** An oil fill-in, a drain plug, and an oil side glass make it possible to add and maintain proper oil levels. The use of oil provides better heat transfer and better solids settling compared to grease.

Bearing sealing

Labyrinth sealing ensures that the lubricant remains in and contaminants are kept out.

Shaft configuration

The advanced bearing bracket features a fixed shaft instead of the floating design of the standard bearing. In addition, stainless steel shaft sleeves are available.

Available bearing brackets

Availability per size

The table below highlights the four different bearing bracket sizes and their corresponding pumps.

	Pump size							Size
	125	160	200	250	315/316	400	500	
32								
40								
50								
65								
80								
100								
125								
150								
200								
250								
300					300-350		300-450	

*Sizes 80-316 and 100-316 have bearing bracket size 42.

The table below highlights the options available for the different bearing brackets.

FEATURE	OPTIONS	BEARING BRACKET SIZES 24*/32/42		BEARING BRACKET SIZES 60
		STANDARD	ADVANCED	ADVANCED
Lubrication	Grease for life	Standard	N/A	N/A
	Regreasable	N/A	Standard	Standard
	Oil lubrication	N/A	Optional	Optional
Bearing sealing	Lip seal	Standard	N/A	Standard for grease lubrication
	Labyrinth seal	N/A	Standard	Standard for oil lubrication and Optional for grease lubrication
Mechanical seal	Unbalanced	Standard		
	Unbalanced + shaft sleeve	Optional		
	Balanced + shaft sleeve	N/A		Optional
	Single cartridge	Optional		Optional (with and without shaft sleeve)
	Single cartridge + quench	Optional		Optional (with and without shaft sleeve)
	Double cartridge	Optional		Optional (with and without shaft sleeve)
Sensor connections	Temperature/vibration	Optional		

*Bearing bracket 24 is only available on standard configuration.

A complete range of seal options

Sealing options

	DESCRIPTION	VERSION [†]
Unbalanced mechanical seal	Elastomer bellow seal provides additional shaft protection over entire seal length	BQ ₇ EGG-WA*
		BQ ₇ VGG
		Q ₇ Q ₇ EGG
		Q ₇ Q ₇ VGG
		U ₃ AEGG
		U ₃ AVGG
Balanced mechanical seal	Can sustain higher pressure across seal faces and generates less heat	BQ ₁ E
Cartridge seal (single)	Pre-assembled cartridge seals simplify installation/service	BQ ₁ E
		Q ₁ Q ₁ V
Cartridge seal (single & quench)	Quench used when pumping cold fluids or ones that crystallize (hydrocarbons)	BQ ₁ E
		Q ₁ Q ₁ V
Cartridge seal (double)	Double seals when 'no leak' is allowed, as when chemically noxious fluids are pumped	BQ ₁ E / BQ ₁ E
		Q ₁ Q ₁ E / BQ ₁ E

[†]Version: Rotating side material + Stationary side material + Elastomer material + Spring material + other material

B= Resin impregnated carbon; **Q₁**, **Q₇**= Silicon carbide; **A**= Antimony impregnated carbon; **U₃**= Tungsten carbide; **E**= EPDM; **V**= FKM; **G**= AISI 316

*WRAS certified (potable water). Other versions of seals are available upon request.

Other configurations

Casing drilling and tapping

Different flange drillings and pressure taps are available to meet the different piping and measuring needs.

	AVAILABILITY
Drilled according to PN16	Standard
Drilled according to PN10	Optional
Drilled according to PN10/16 (suction PN10 / discharge PN16)	Optional
Drilled according to ASME B16.5 Cl.150	Optional
Case gasket O-ring	Standard
Case drain with flange & valve	Optional
Pressure gauge connections (on suction and second discharge)	Optional
Sensor connections - temperature & vibration (on pump and/or motor sides)	Optional

Impeller trimming and balancing

As a standard, all NSC impellers (regardless of material type) are balanced with a grade G6.3 according to ISO 1940/1. The higher grade of G2.5 is available as an option. Impellers can also be trimmed at a specific requested duty point to optimize usage.

Base frame and support feet

All the e-NSC pump housings are designed with feet. The e-NSCS (block) pumps are provided from IEC motor size 160 with B35 motors. An optional base frame is provided for ease of installation.

NSCS PUMPS	AVAILABILITY
Base frame	Optional for all sizes

The e-NSCF/C (frame-mounted) pumps are provided with fabricated carbon steel base frames. The following options are offered on the frames.

NSCF/C PUMPS	AVAILABILITY
Shims and jack screws	Standard for all sizes
Drip pan	Optional for all sizes
Earthing connection	Standard on bearing bracket size 60, optional for all other sizes
Motor alignment bolts	Standard on bearing bracket size 60, optional for all other sizes
Pedestal connection port	Optional for all sizes
Lifting lugs	Optional for all sizes
Foundation bolts	Optional for all sizes

Make your system even more efficient

HYDROVAR HVL and HYDROVAR SMART

Energy is the greatest cost of running any pump. Fifth generation HYDROVAR Variable Speed Drives work with your ultra-efficient e-NSC system to make it even more efficient. They can further reduce your energy use by up to 70%, depending on your costs and operating times. At that rate, the HYDROVAR typically pays for itself within two years.

HYDROVAR HVL: 1.5kW to 22kW, can be mounted to the motor or wall.

HYDROVAR SMART: Over 22kW, it uses HYDROVAR intelligence and can be integrated with any frequency drive. In addition, its slim design allows for installation anywhere, even inside the drive's control panel.



FEATURES	HYDROVAR HVL	HYDROVAR SMART
Fits onto any standard asynchronous motor	●	
Advanced motor control	●	●
Embedded THDi filter	●	on request
Extended communication capabilities	●	●
Easy to commission and operate	●	●
Multipump capability	up to 8	up to 4

Select the right pump for your variable speed system

When selecting a pump for a variable speed controlled system, the whole working range of the pump must be taken into consideration. Since a pump mostly works in partial load, the best efficiency point should not be at the maximum duty point.

The selected pump should have a maximum duty point to the right of the best efficiency point, within an acceptable range (e.g. opt -10%).

This selection guarantees that, in partial load, the pump works at high efficiency within a wide range. When it is possible that load conditions will be low for long periods, the system should be split into two pumps, or a jockey pump should be installed.

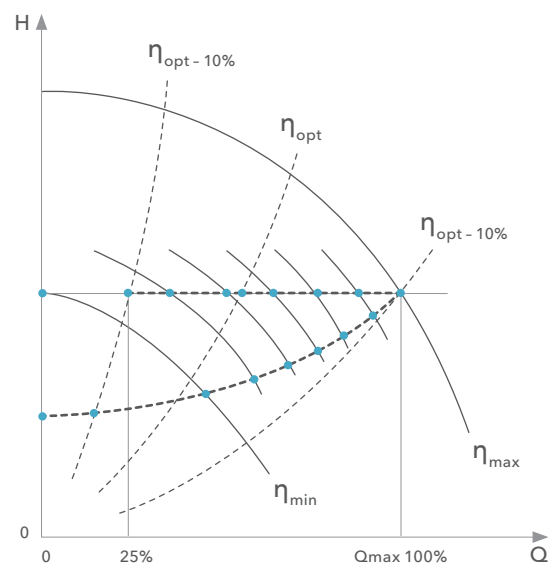

Testing, reports and certifications

The following tests, reports and certifications are available for the e-NSC pumps.

PERFORMANCE-RELATED TESTS

Hydrostatic pressure test	Standard for all e-NSC pumps
Performance test grade	Grade 3B; standard for all e-NSC pumps Grade 2B; standard for bearing bracket size 60 and optional for all other e-NSC pumps Grade 1B, 1E, 1U; optional for bearing sizes 32 (except 65-250, 80-200, 80-250), 42 and 60
NPSH test	Test and report are available upon request for all e-NSC pumps
Vibration test	Test and report are available upon request for all e-NSC pumps
Bearing temperature test	Test and report are available upon request for e-NSCF/C pumps

MATERIAL-RELATED TESTS & REPORTS

Certificate of compliance EN10204-2.1	Available upon request for different materials and configurations
Test report EN10204-2.2	Available upon request for different materials and configurations
Hardness test (Brinell HB)	Test and report are available upon request for all e-NSC pumps
X-ray test	Test and report are available upon request for all e-NSC pumps
Ultrasonic test	Test and report are available upon request for all e-NSC pumps
Dye penetrant test	Test and report are available upon request for all e-NSC pumps
Pickling and passivation	Optional for the stainless steel versions (NN/NR)

PAINTING

Painting certificate	L1.3 is the paint standard; painting certificate is available upon request
Customer-specified painting	Different types of painting color/thickness/grade are available upon request

POTABLE WATER CERTIFICATES

ACS	The e-NSC range is ACS certified; certification is provided as standard
DM 174	The e-NSC range is DM 174 certified; certification is provided as standard

Xylect™ makes product selection easy

Xylect selection tool

Xylect™ is an online pump selection tool with an extensive database of product information across the entire range of Xylem pumps and related products. It puts detailed, up-to-date information about thousands of products and accessories right at your fingertips. Plus, with multiple search options and an assortment of helpful project management capabilities, Xylect makes it easy to hone in on the optimal selection for your application. Try it out at Xylect.com.

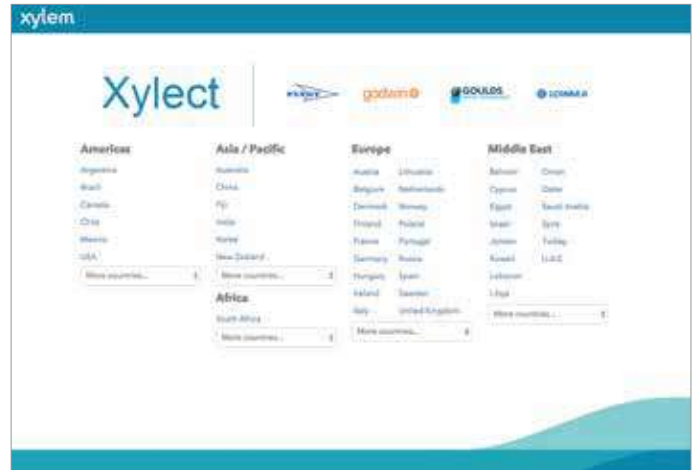

Xylem |'zīləm|

- 1) The tissue in plants that brings water upward from the roots;
- 2) a leading global water technology company.

We're a global team unified in a common purpose: creating advanced technology solutions to the world's water challenges. Developing new technologies that will improve the way water is used, conserved, and re-used in the future is central to our work. Our products and services move, treat, analyze, monitor and return water to the environment, in public utility, industrial, residential and commercial building services settings. Xylem also provides a leading portfolio of smart metering, network technologies and advanced analytics solutions for water, electric and gas utilities. In more than 150 countries, we have strong, long-standing relationships with customers who know us for our powerful combination of leading product brands and applications expertise with a strong focus on developing comprehensive, sustainable solutions.

For more information on how Xylem can help you, go to www.xylem.com



For information and technical support
Xylem Service Italia Srl

Via Dottor Vittorio Lombardi 14
36075 - Montecchio Maggiore (VI) - Italy
Tel. (+39) 0444 707111
Fax (+39) 0444 491043
www.xylem.com/lowara