

60 Hz



CO Series

CENTRIFUGAL PUMPS WITH OPEN IMPELLER EQUIPPED WITH
IE2/IE3 MOTORS COMPLYING WITH REGULATION (EC) no. 640/2009

Cod. 191013611 Rev.A Ed.07/2012

 **LOWARA**
a xylem brand

Open impeller centrifugal electric pumps and threaded connections

CO-COM 60 Hz Series

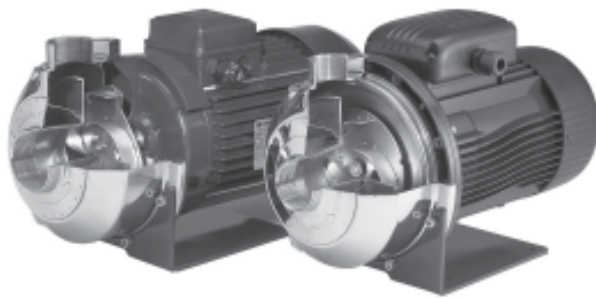

MARKET SECTORS

CIVIL, INDUSTRIAL.

APPLICATIONS

- Washing of metal parts and/or surface treatment.
- Washing of produce in the packaging industry.
- Food industry washing equipment and systems.
- Dyeing plant and textile industry.
- Plants for the circulation and transfer of moderately viscous liquids, with light chemical aggressiveness.
- Industrial washing machines and commercial dishwashers.

CONSTRUCTION FEATURES

- Close-coupled, single-impeller centrifugal pump with axial suction and radial delivery.
- Threaded suction and delivery ports (Rp ISO 7).
- Compact construction; adaptor for motor/pump coupling; the impeller is keyed directly to the motor shaft extension.
- Back pull-out design; no need to disconnect the pump body from the system pipes.
- **AISI 316L** stainless steel open impeller with four pressed vanes welded onto base disk.
- Impeller's front **wear surface** consists of a sturdy **AISI 316L** stainless steel plate welded onto the suction port.
- **AISI 316L** stainless steel **pump body and seal housing disk**, with no diffusers or cavities for easier cleaning and maintenance.
- Pump body tightened by 8 screws allowing rotation of the discharge head.
- **Mechanical seal:**
Standard version: Carbon/Ceramica faces, **FPM** elastomers. The other parts are made of AISI 316L stainless steel.
"K" version : faces are made of **Silicon Carbide and Tungsten Carbide**. **FPM** Elastomers. The other parts are made of AISI 316L stainless steel.
- **FPM O-Rings.**

SPECIFICATIONS

PUMP

- **Delivery** up to 900 l/min (54 m³/h).
- **Head** up to 24 m.
- **Temperature** of pumped liquid: -10°C to +110°C for standard version.
- Maximum working **pressure** : 8 bar (PN 8).
- **Suspended solids** handled up to:
CO350: 11 mm.
CO500: 20 mm.

MOTOR

- Asynchronous, squirrel cage rotor, enclosed construction in aluminium casing, external ventilation.
- **Protection:** IP55.
- Class 155 (F) **insulation.**
- Performances according to EN 60034-1.
- Maximum ambient **temperature:** 40°C.
- **Standard voltage:**
- **Single-phase** version: 220-230 V 60 Hz, 2 poles with built-in automatic reset overload protection up to 1,5 kW. For higher powers the protection must be provided by the user.
- **Three-phase** version: 220-230/380-400 V 60 Hz, 2 poles; overload protection to be provided by the user.
- Condensate drain plugs on all motors.

☐ **All components in contact with pumped liquid are made of AISI 316L stainless steel**

☐ **Mechanical seal made of Silicon carbide/tungsten carbide/FPM in the "K" version**

OPTIONAL FEATURES

- Different voltages and frequencies.
- Different materials for the mechanical seal and O-rings.

CO - COM SERIES IDENTIFICATION CODE

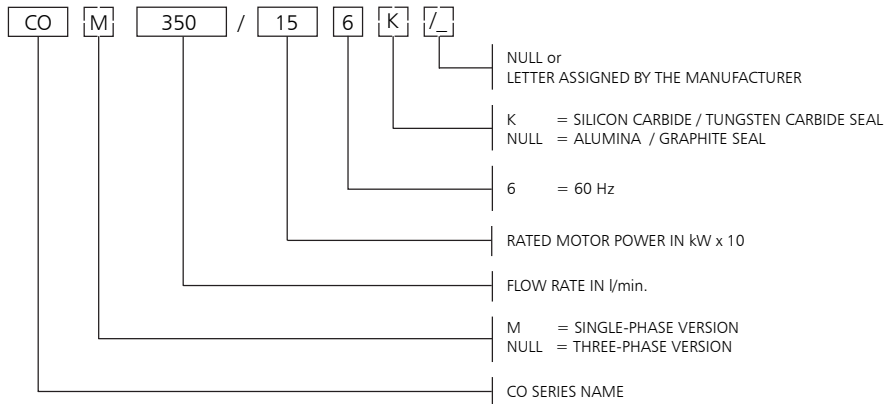

EXAMPLE : COM 350/156K
 CO series electric pump, single-phase, flow rate 350 l/min,
 rated power 1,5 kW, 60 Hz version, Silicon Carbide / Tungsten Carbide seal.

RATING PLATE

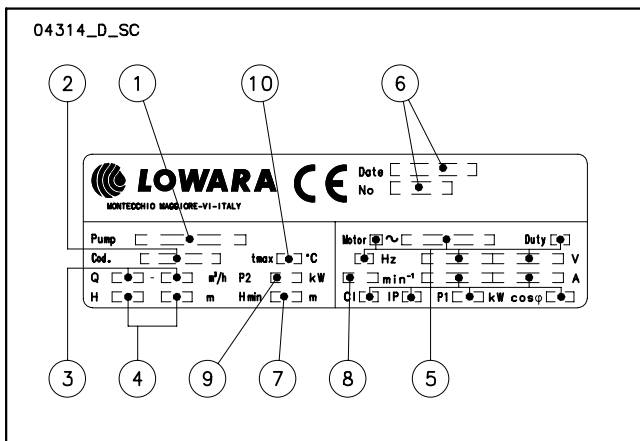

LEGEND

- 1 - Electric pump type
- 2 - Code
- 3 - Delivery range
- 4 - Head range
- 5 - Motor type
- 6 - Date of manufacture and serial number
- 7 - Minimum head
- 8 - Speed
- 9 - Rated output
- 10 - Maximum operating temperature

**CO - COM SERIES
LIST OF MODELS AND TABLE OF MATERIALS**

04309_A_DS

VERSIONS	
SINGLE-PHASE	THREE-PHASE
COM 350/076	CO 350/076
COM 350/096	CO 350/096
COM 350/116	CO 350/116
COM 350/156	CO 350/156
COM 500/156	CO 500/156
COM 500/226	CO 500/226
	CO 500/306

co-60Hz-en_a_mo

REF. N.	NAME	MATERIAL	REFERENCE STANDARDS	
			EUROPE	USA
1	Pump body	Stainless steel	EN 10088-1-X2CrNiMo17-12-2 (1.4404)	AISI 316L
2	Impeller	Stainless steel	EN 10088-1-X2CrNiMo17-12-2 (1.4404)	AISI 316L
3	Seal housing	Stainless steel	EN 10088-1-X2CrNiMo17-12-2 (1.4404)	AISI 316L
4	Shaft extension	Stainless steel	EN 10088-1-X2CrNiMo17-12-2 (1.4404)	AISI 316L
5	Impeller locknut and washer	Stainless steel	EN 10088-1-X5CrNiMo17-12-2 (1.4401)	AISI 316
6	Fill/drain plugs	Stainless steel	EN 10088-1-X5CrNiMo17-12-2 (1.4401)	AISI 316
7	Mechanical seal	Ceramic / resin impregnated Carbon / FPM (standard version)		
8	Elastomers	FPM (standard version)		
9	Adapter	Aluminium	EN 1706-AC-AISi11Cu2(Fe)DF	ASTM Class 25
10	Pump body fastening bolts & screws	Galvanized steel		

CO - COM SERIES MECHANICAL SEAL

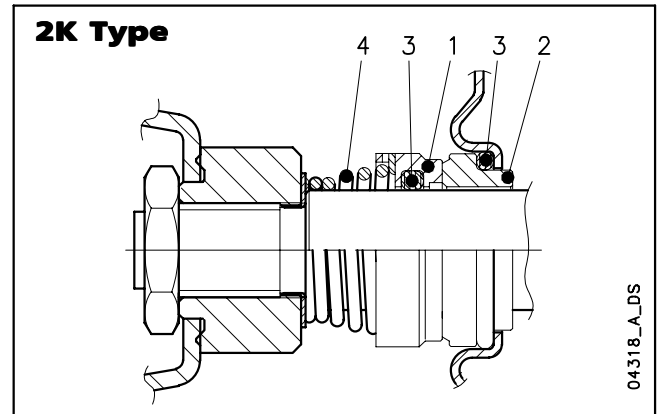
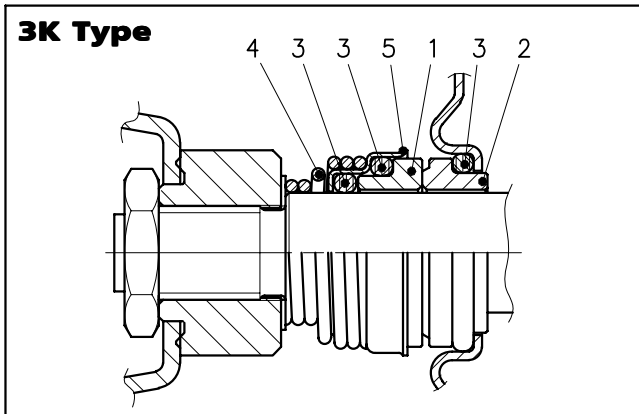

04318_A_DS

LIST OF MATERIALS

POSITION 1 - 2	POSITION 3	POSITION 4 - 5
B : Resin impregnated carbon	E : EPDM	G : AISI 316
C : Special resin impregnated carbon	V : FPM	
V : Ceramic		
Q ₁ : Silicon Carbide		
U ₃ : Tungsten Carbide		

SEAL TYPES

co_ten-mec-3-en_a_tm

TYPE	POSITION					TEMPERATURE (°C)
	1 ROTATING ASSEMBLY	2 FIXED ASSEMBLY	3 ELASTOMERS	4 SPRINGS	5 OTHER COMPONENTS	
STANDARD MECHANICAL SEAL						
3K - VB V G G	V	B	V	G	G	-10 +110
OTHER MECHANICAL SEAL TYPES						
3K - VC V G G	V	C	V	G	G	-10 +110
3K - Q ₁ CVGG	Q ₁	C	V	G	G	-10 +110
3K - Q ₁ Q ₁ VGG	Q ₁	Q ₁	V	G	G	-10 +110
2K - U ₃ Q ₁ VGG	U ₃	Q ₁	V	G	G	-10 +110
2K - U ₃ U ₃ VGG *	U ₃	U ₃	V	G	G	-10 +110
3K - VBEGG	V	B	E	G	G	-30 +110
3K - VCEGG	V	C	E	G	G	-30 +110
3K - Q ₁ CEGG	Q ₁	C	E	G	G	-30 +110
3K - Q ₁ Q ₁ EGG	Q ₁	Q ₁	E	G	G	-30 +110
2K - U ₃ Q ₁ EGG	U ₃	Q ₁	E	G	G	-30 +110
2K - U ₃ U ₃ EGG *	U ₃	U ₃	E	G	G	-30 +110

* Version with anti-rotation lockpin available on request.

co_tipi-ten-mec-3-en_b_tc

COMPLETE PUMP PRESSURE / TEMPERATURE OPERATING LIMITS (WITH ANY OF THE SEALS LISTED ABOVE)

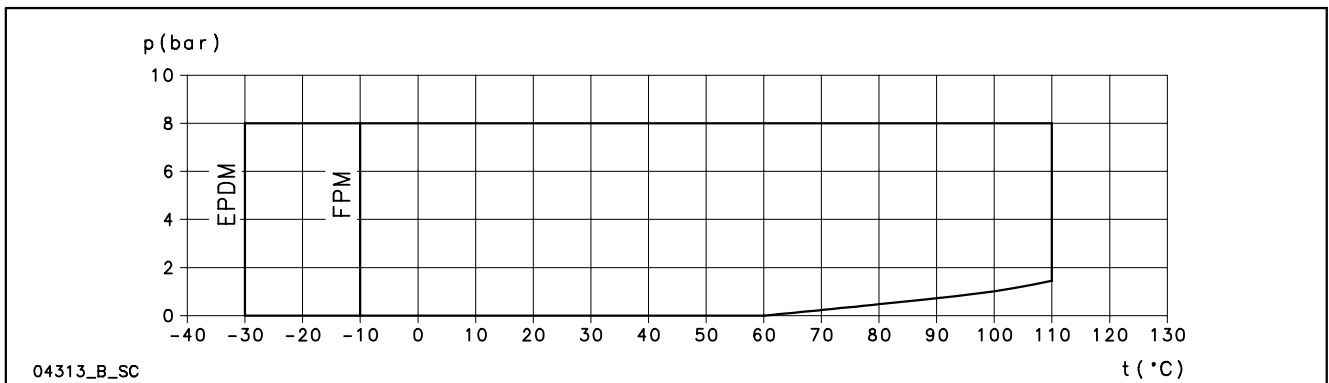

04313_B_SC

t (°C)

CO 350 SERIES OPERATING CHARACTERISTICS AT 60 Hz, 2 POLES

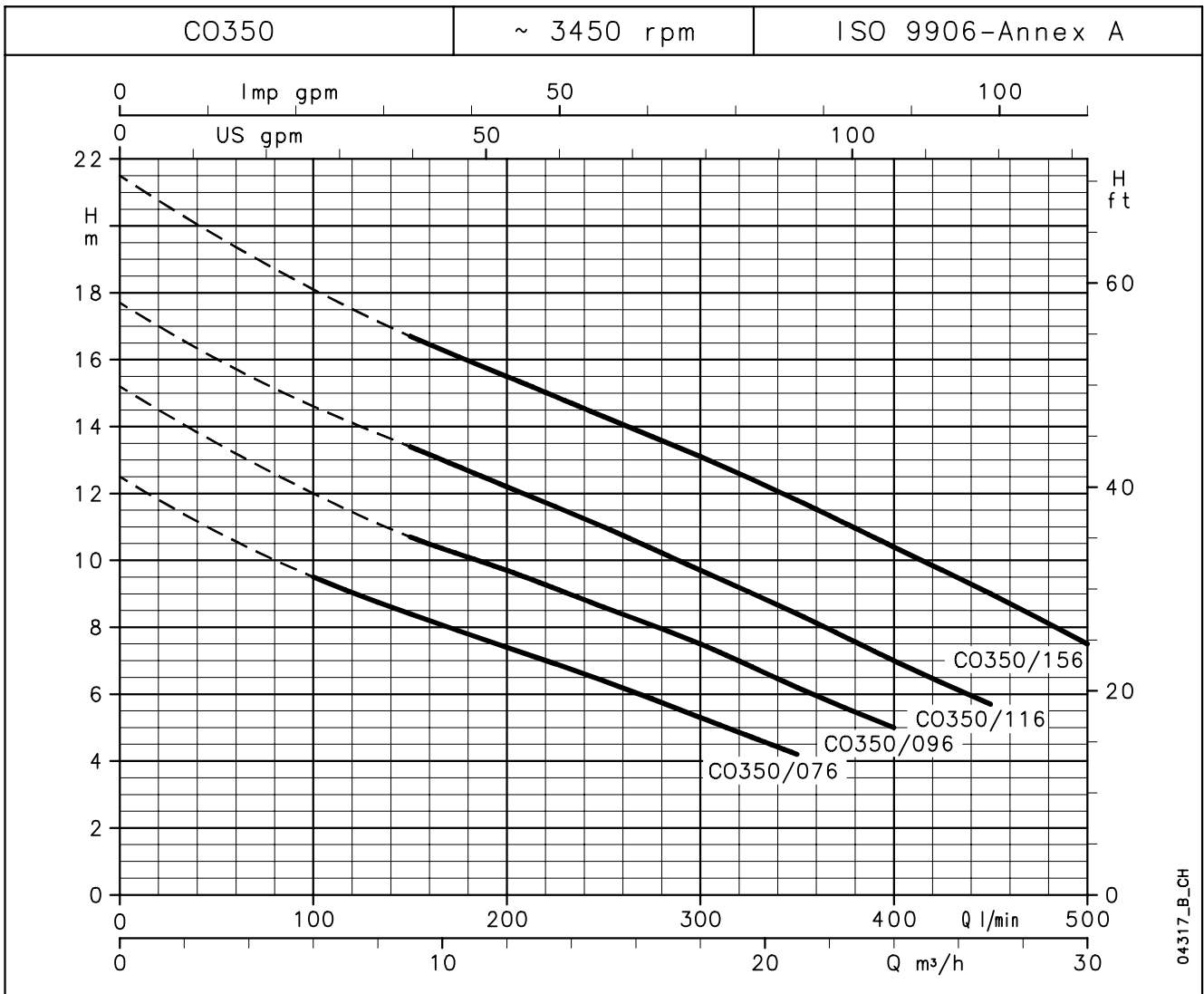

HYDRAULIC PERFORMANCE TABLE AT 60 Hz, 2 POLES

PUMP TYPE	RATED POWER		Q = DELIVERY									
			l/min 0	100	150	200	250	300	350	400	450	500
			m ³ /h 0	6	9	12	15	18	21	24	27	30
H = TOTAL HEAD METRES COLUMN OF WATER												
CO(M) 350/076	0,75	1	12,5	9,5	8,4	7,4	6,4	5,3	4,2	-	-	-
CO(M) 350/096	0,9	1,2	15,2	-	10,7	9,7	8,6	7,5	6,2	5	-	-
CO(M) 350/116	1,1	1,5	17,7	-	13,4	12,2	11,0	9,7	8,4	7	5,7	-
CO(M) 350/156	1,5	2	21,5	-	16,7	15,5	14,3	13,1	11,8	10,4	9	7,5

ELECTRICAL DATA AT 60 Hz, 2 POLES

co350-2p60-en_a_th

PUMP TYPE	MOTOR TYPE	INPUT POWER*	INPUT CURRENT* 220-230 V	CAPACIT.* μF / 450 V	PUMP TYPE	MOTOR TYPE	INPUT POWER*	INPUT CURRENT* 220-230 V	INPUT CURRENT* 380-400 V
		kW	A				kW	A	A
COM350/076	SM71BG/1076	1,01	4,62	20	CO350/076	SM80BG/307PE	0,90	3,01	1,74
COM350/096	SM71BG/1096	1,23	5,57	25	CO350/096	SM80BG/311PE	1,09	3,82	2,20
COM350/116	SM80BG/1116	1,53	7,09	30	CO350/116	SM80BG/311PE	1,39	4,45	2,57
COM350/156	SM80BG/1156	2,00	9,29	40	CO350/156	SM80BG/315PE	1,80	5,71	3,30

*Maximum value in specified range

co350-2p60-en_d_te

CO 500 SERIES OPERATING CHARACTERISTICS AT 60 Hz, 2 POLES

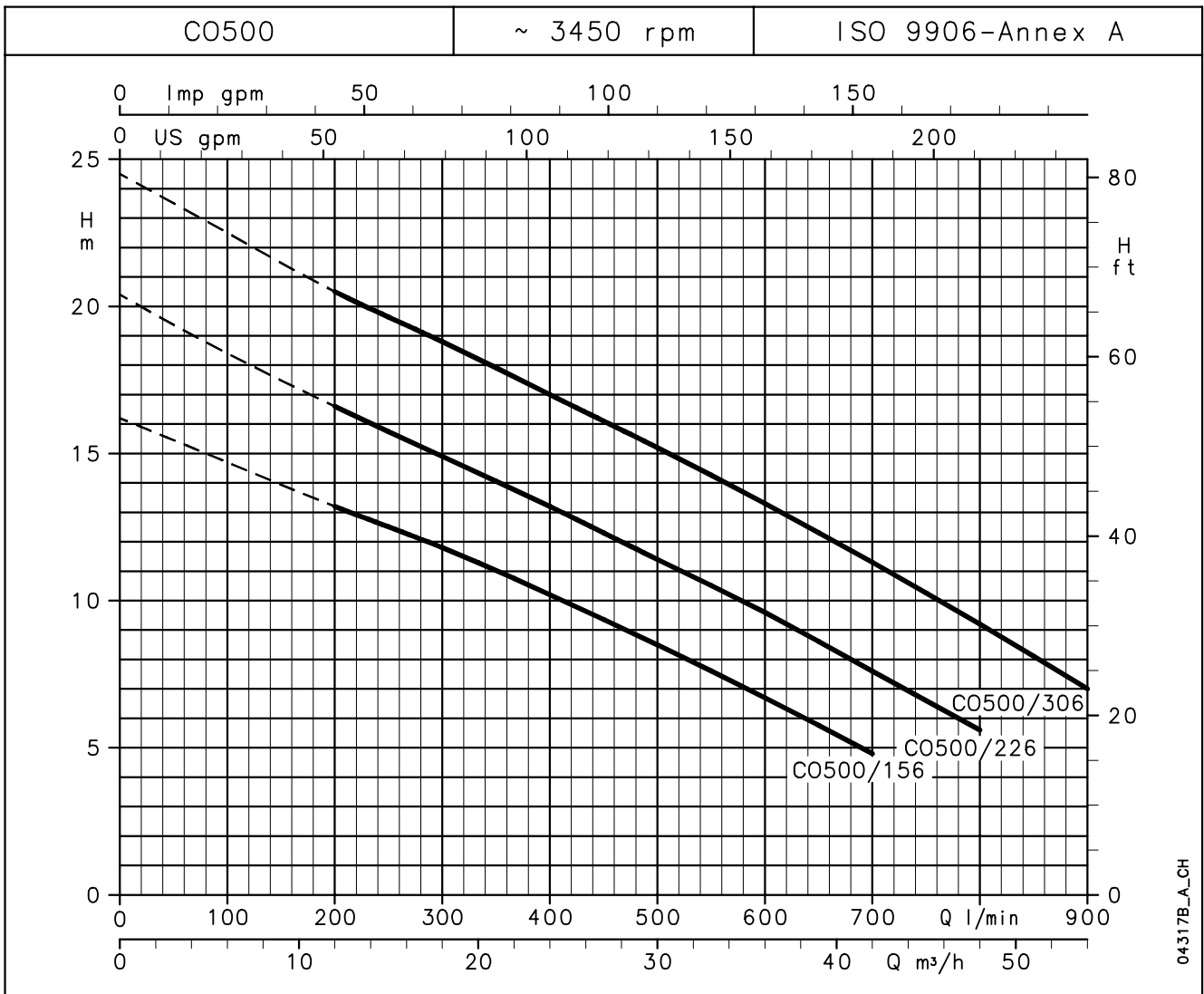

HYDRAULIC PERFORMANCE TABLE AT 60 Hz, 2 POLES

PUMP TYPE	RATED POWER		Q = DELIVERY									
			l/min	200	250	300	400	500	600	700	800	900
			0	12	15	18	24	30	36	42	48	54
	kW	HP	H = TOTAL HEAD METRES COLUMN OF WATER									
CO(M) 500/156	1,5	2	16,2	13,2	12,5	11,8	10,2	8,5	6,7	4,8	-	-
CO(M) 500/226	2,2	3	20,4	16,6	15,7	14,9	13,2	11,4	9,6	7,6	5,6	-
CO 500/306	3	4	24,5	20,5	19,6	18,8	17	15,2	13,3	11,3	9,2	7

ELECTRICAL DATA AT 60 Hz, 2 POLES

co500-2p60-en_a_th

PUMP TYPE	MOTOR TYPE	INPUT POWER*	INPUT CURRENT* 220-230 V	CAPACIT. μF / 450 V	PUMP TYPE	MOTOR TYPE	INPUT POWER*	INPUT CURRENT* 220-230 V	INPUT CURRENT* 380-400 V
COM500/156	SM80BG/1156	2,04	9,45	40	CO 500/156	SM80BG/315PE	1,84	5,81	3,35
COM500/226	PLM90BG/1226	2,61	12,2	60	CO 500/226	PLM90BG/322	2,63	8,28	4,78
-	-	-	-	-	CO 500/306	PLM90BG/330	3,47	10,8	6,22

*Maximum value in specified range

co500-2p60-en_d_te

MOTORS FOR CO SERIES

Standard supplied IE2/IE3 three-phase surface motors $\geq 0,75$ kW are compliant with Regulation (EC) no. 640/2009 and IEC 60034-30.

Electrical performances according to EN 60034-1.

Insulation class 155 (F). IP55 protection. Condensate drain plugs on standard version.

Cooling by fan according to EN 60034-6.

Cable gland metric size according to EN 50262. Standard voltage:

- **Single-phase** version: 220-230 V 60 Hz (incorporated automatic-reset overload protection).
- **Three-phase** version : 220 V Δ , 380 V Y, 60 Hz (overload protection to be provided by the user).

SINGLE-PHASE MOTORS AT 60 Hz, 2 POLES

P _N kW	MOTOR TYPE	IEC SIZE	Construction Design	INPUT CURRENT	CAPACITOR		DATA FOR 220 V 50 Hz VOLTAGE						
				I _n (A)	μ F	V	min ⁻¹	I _s / I _n	η %	cos ϕ	T _n	T _s /T _n	T _m /T _n
				220-230 V							Nm		
0,75	SM71BG/1076	71	SPECIAL	4,98-4,88	20	450	3380	3,90	69,8	0,98	2,12	0,64	1,91
0,9	SM71BG/1096	71		6,04-5,96	25	450	3370	3,80	72,9	0,98	2,69	0,58	1,86
1,1	SM80BG/1116	80		6,94-6,89	30	450	3435	4,54	74,2	0,97	3,06	0,62	2,03
1,5	SM80BG/1156	80		9,28-9,35	40	450	3455	4,91	76,3	0,96	4,14	0,49	2,19
2,2	PLM90BG/1226	90		12,3-11,7	60	450	3455	4,99	83,4	0,98	6,08	0,54	2,06

co-motm-2p60-en_a_te

THREE-PHASE MOTORS AT 60 Hz, 2 POLES

P _N kW	Efficiency η_N												Year of construction	
	%													
	Δ 220 V Y 380 V			Δ 230 V Y 400 V			Δ 380 V Y 660 V			Δ 400 V Y 690 V				IE
	4/4	3/4	2/4	4/4	3/4	2/4	4/4	3/4	2/4	4/4	3/4	2/4		
0,75	83,4	82,4	79,0	83,4	82,4	79,0	83,4	82,4	79,0	83,4	82,4	79,0	3	By June 2011
0,9	85,6	85,0	82,1	85,6	85,0	82,1	85,6	85,0	82,1	85,6	85,0	82,1		
1,1	85,6	85,0	82,1	85,6	85,0	82,1	85,6	85,0	82,1	85,6	85,0	82,1		
1,5	87,2	87,0	84,6	87,2	87,0	84,6	87,2	87,0	84,6	87,2	87,0	84,6		
2,2	85,5	85,5	84,5	85,5	85,5	84,5	85,5	85,5	84,5	85,5	85,5	84,5		
3	87,8	88,0	86,0	87,8	88,0	86,0	87,8	88,0	86,0	87,8	88,0	86,0	2	

P _N kW	Manufacturer		IEC SIZE	Construction Design	N. of Poles	f _n Hz	Data for 380 V / 60 Hz				
	Lowara srl Unipersonale Reg. No. 341820260 Montecchio Maggiore Vicenza - Italia						cos ϕ	I _s / I _n	T _N Nm	T _s /T _N	T _m /T _n
	Model										
0,75	SM80BG /307 PE		80	SPECIAL	2	60	0,79	8,25	2,05	3,80	4,02
0,9	SM80BG /311 PE		80				0,80	9,11	3,01	4,15	4,29
1,1	SM80BG /311 PE		80				0,80	9,11	3,01	4,15	4,29
1,5	SM80BG /315 PE		80				0,82	9,79	4,10	4,36	4,37
2,2	PLM90BG /322		90				0,83	9,59	6,00	3,80	4,02
3	PLM90BG /330		90				0,84	9,12	8,22	3,52	3,65

P _N kW	Voltage U _N								n _N min ⁻¹	See note.	Operating conditions **		
	Δ		Y		Δ		Y				Altitude above sea Level (m)	T. amb min/max °C	ATEX
	220 V	230 V	380 V	400 V	380 V	400 V	660 V	690 V					
	I _N (A)												
0,75	3,03	3,01	1,75	1,74	1,75	1,74	1,01	1,00	3490 ÷ 3500	VI 1000	-15 / 40	No	
0,9	4,24	4,24	2,45	2,45	2,44	2,43	1,41	1,40	3490 ÷ 3505				
1,1	4,24	4,24	2,45	2,45	2,44	2,43	1,41	1,40	3490 ÷ 3505				
1,5	5,58	5,53	3,22	3,19	3,23	3,22	1,86	1,86	3485 ÷ 3505				
2,2	8,14	8,12	4,70	4,69	4,69	4,68	2,71	2,70	3495 ÷ 3505				
3	10,7	10,5	6,19	6,06	6,20	6,11	3,58	3,53	3480 ÷ 3495				

Note: Observe the regulations and codes locally in force regarding sorted waste disposal.

co-ie2-mott-2p60-en_b_te

** Operating conditions to be referred to motor only. About electric pump, refer to limits in user's manual.

AVAILABLE VOLTAGES MOTORS FOR CO SERIES

P _N kW	IEC SIZE	SINGLE-PHASE							
		50 Hz				60 Hz			
		1 x 220-240				1 x 220-230			
		1 x 100				1 x 100			
		1 x 110-120				1 x 110-115			
		1 x 120-127				1 x 120-127			
		1 x 200-210				1 x 200-210			
0,4	63	s	o	o	s	-	o	-	-
0,55	71	s	o	o	s	o	o	o	o
0,75	71	s	o	o	s	o	o	o	o
0,95	71	s	o	o	s	o	o	o	o
1,1	80	s	-	o	s	-	o	-	o
1,5	80	s	-	-	s	-	o	-	o
2,2	90	s	-	-	s	-	-	-	-

s = Standard voltage o = Optional voltage

P _N kW	THREE-PHASE - 2 POLES														
	50 Hz						60 Hz						50/60 Hz		
	3 x 220-230-240/380-400-415						3 x 255-265-277/440-460-480						3 x 230/400 50 Hz		
	3 x 380-400-415/660-690						3 x 380-400/660-690						3 x 265/460 60 Hz		
	3 x 200-208/346-360						3 x 440-460-480/-						3 x 400/690 50 Hz		
	3 x 255-265/440-460						3 x 110-115/190-200						3 x 460/- 60 Hz		
	3 x 290-300/500-525						3 x 200-208/346-360						3 x 400/690 50 Hz		
	3 x 440-460/-						3 x 330-346/575-600						3 x 460/- 60 Hz		
	3 x 500-525/-						3 x 575/-								
	3 x 220-230/380-400														
0,4	s	o	o	o	o	o	s	o	o	o	o	o	o	o	o
0,55	s	o	o	o	o	o	s	o	o	o	o	o	o	o	o
0,75	s	o	o	o	o	o	s	o	o	o	o	o	o	o	o
0,95	s	o	o	o	o	o	s	o	o	o	o	o	o	o	o
1,1	s	o	o	o	o	o	s	o	o	o	o	o	o	o	o
1,5	s	o	o	o	o	o	s	o	o	o	o	o	o	o	o
2,2	s	o	o	o	o	o	s	o	o	o	o	o	o	o	o
3	s	o	o	o	o	o	s	o	o	o	o	o	o	o	o

- = Not available

co-volt-low-a-en_a_te

CO SERIES DIMENSIONS AND WEIGHTS AT 60 Hz, 2 POLES

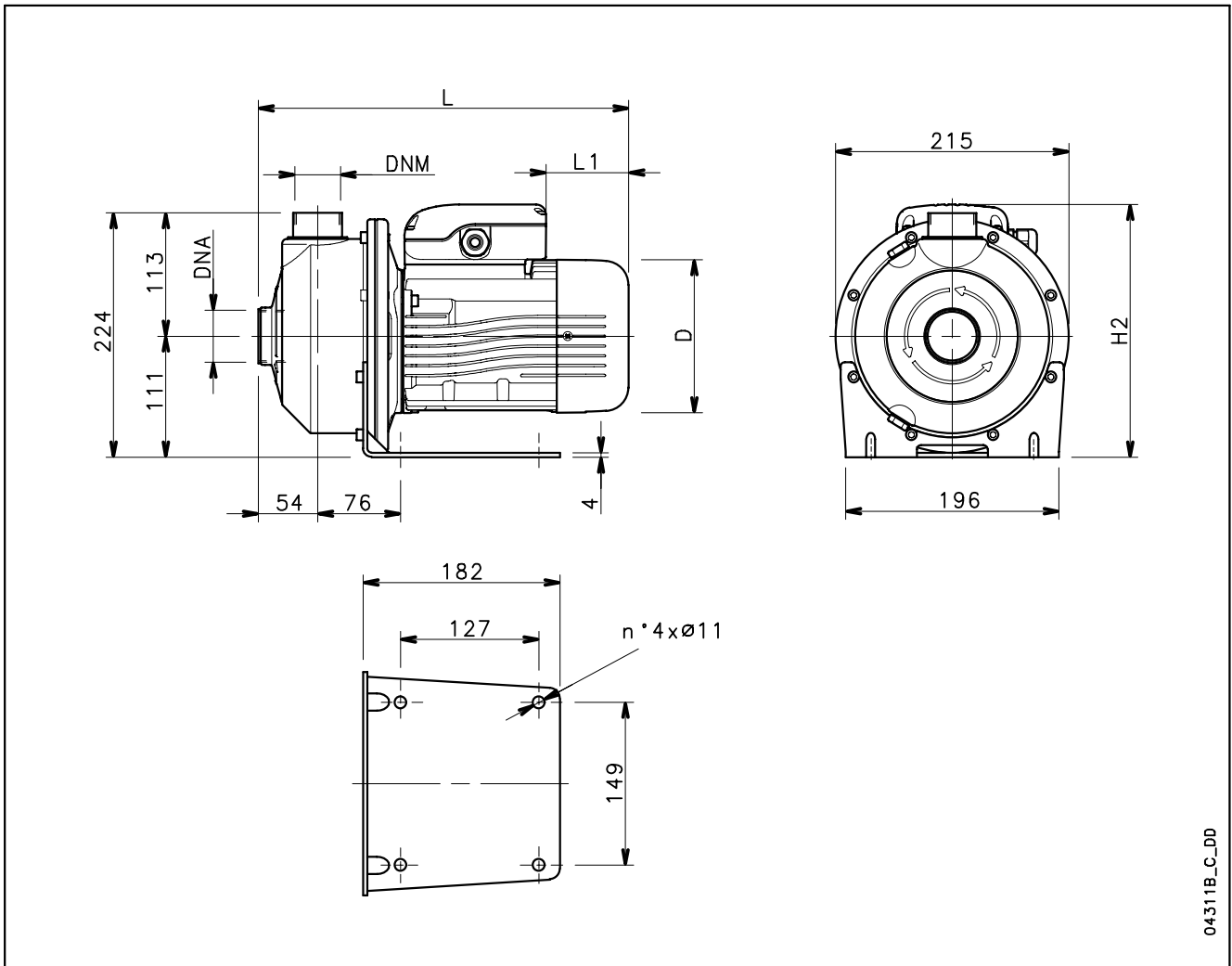

04311B_C_DD

PUMP TYPE	DIMENSIONS (mm)				DNA	DNM	WEIGHT kg
	D	H2	L	L1			
COM 350/076/A	140	232	339	76	Rp 1½	Rp 1¼	12,6
COM 350/096/A	140	241	339	31	Rp 1½	Rp 1¼	13,2
COM 350/116/A	155	248	385	69	Rp 1½	Rp 1¼	14,5
COM 350/156/A	155	248	385	69	Rp 1½	Rp 1¼	16,2
COM 500/156/A	155	248	385	69	Rp 2	Rp 1½	16,2
COM 500/226/P	174	262	430	84	Rp 2	Rp 1½	17,8
CO 350/076/D	155	240	385	114	Rp 1½	Rp 1¼	14,4
CO 350/096/D	155	240	385	114	Rp 1½	Rp 1¼	14,4
CO 350/116/D	155	240	385	114	Rp 1½	Rp 1¼	16
CO 350/156/D	155	240	385	114	Rp 1½	Rp 1¼	17,5
CO 500/156/D	155	240	385	114	Rp 2	Rp 1½	17,5
CO 500/226/C	174	245	430	172	Rp 2	Rp 1½	23
CO 500/306/P	174	245	430	172	Rp 2	Rp 1½	23

co-2p60-en_e_td

TECHNICAL APPENDIX

TYPICAL APPLICATIONS OF CO SERIES ELECTRIC PUMPS

Water Purification:

De-ionized water
Water treatment
Filtration
Commercial pools

Food and Drink:

Food processing
Bottle washing
Citrus processing
Dish washing
Brewing
Sanitary ware

Medical:

Laser cooling
Medical chillers
Sanitary equipment

Heating, Ventilating & Air Conditioning (HVAC)

Air scrubbers
Water re-circulation
Cooling towers
Cooling systems
Temperature control
Chillers
Induction heating
Heat exchangers
Water heating

Graphics:

Film washing
Cooling

Plastics:

Extrusion machines
Temperature control
Manufacture of polymers

Waste Management:

Waste treatment

Machine Tool:

Degreasing
Parts washing
Chemical treatment
Heat treatment

Laundry:

Industrial and Commercial washing

General Industry:

Spray Booths
Light chemical transfer
Booster systems
Firefighting systems

NPSH

The minimum operating values that can be reached at the pump suction end are limited by the onset of cavitation.

Cavitation is the formation of vapour-filled cavities within liquids where the pressure is locally reduced to a critical value, or where the local pressure is equal to, or just below the vapour pressure of the liquid.

The vapour-filled cavities flow with the current and when they reach a higher pressure area the vapour contained in the cavities condenses. The cavities collide, generating pressure waves that are transmitted to the walls. These, being subjected to stress cycles, gradually become deformed and yield due to fatigue. This phenomenon, characterized by a metallic noise produced by the hammering on the pipe walls, is called incipient cavitation.

The damage caused by cavitation may be magnified by electrochemical corrosion and a local rise in temperature due to the plastic deformation of the walls. The materials that offer the highest resistance to heat and corrosion are alloy steels, especially austenitic steel. The conditions that trigger cavitation may be assessed by calculating the total net suction head, referred to in technical literature with the acronym NPSH (Net Positive Suction Head).

The NPSH represents the total energy (expressed in m.) of the liquid measured at suction under conditions of incipient cavitation, excluding the vapour pressure (expressed in m.) that the liquid has at the pump inlet.

To find the static height h_z at which to install the machine under safe conditions, the following formula must be verified:

$$h_p + h_z \geq (\text{NPSHr} + 0.5) + h_f + h_{pv}$$

where:

- h_p** is the absolute pressure applied to the free liquid surface in the suction tank, expressed in m. of liquid; h_p is the quotient between the barometric pressure and the specific weight of the liquid.
- h_z** is the suction lift between the pump axis and the free liquid surface in the suction tank, expressed in m.; h_z is negative when the liquid level is lower than the pump axis.
- h_f** is the flow resistance in the suction line and its accessories, such as: fittings, foot valve, gate valve, elbows, etc.
- h_{pv}** is the vapour pressure of the liquid at the operating temperature, expressed in m. of liquid. h_{pv} is the quotient between the P_v vapour pressure and the liquid's specific weight.
- 0,5** is the safety factor.

The maximum possible suction head for installation depends on the value of the atmospheric pressure (i.e. the elevation above sea level at which the pump is installed) and the temperature of the liquid.

To help the user, with reference to water temperature (4° C) and to the elevation above sea level, the following tables show the drop in hydraulic pressure head in relation to the elevation above sea level, and the suction loss in relation to temperature.

Water temperature (°C)	20	40	60	80	90	110	120
Suction loss (m)	0,2	0,7	2,0	5,0	7,4	15,4	21,5

Elevation above sea level (m)	500	1000	1500	2000	2500	3000
Suction loss (m)	0,55	1,1	1,65	2,2	2,75	3,3

Friction loss is shown in the tables at pages 16-17 of this catalogue. To reduce it to a minimum, especially in cases of high suction head (over 4-5 m.) or within the operating limits with high flow rates, we recommend using a suction line having a larger diameter than that of the pump's suction port. It is always a good idea to position the pump as close as possible to the liquid to be pumped.

FLOW RESISTANCE

TABLE OF FLOW RESISTANCE IN BENDS, VALVES AND GATES

The flow resistance is calculated using the equivalent pipeline length method according to the table below:

ACCESSORY TYPE	DN											
	25	32	40	50	65	80	100	125	150	200	250	300
	Equivalent pipeline length (m)											
45° bend	0,2	0,2	0,4	0,4	0,6	0,6	0,9	1,1	1,5	1,9	2,4	2,8
90° bend	0,4	0,6	0,9	1,1	1,3	1,5	2,1	2,6	3,0	3,9	4,7	5,8
90° smooth bend	0,4	0,4	0,4	0,6	0,9	1,1	1,3	1,7	1,9	2,8	3,4	3,9
Union tee or cross	1,1	1,3	1,7	2,1	2,6	3,2	4,3	5,3	6,4	7,5	10,7	12,8
Gate	-	-	-	0,2	0,2	0,2	0,4	0,4	0,6	0,9	1,1	1,3
Non return valve	1,1	1,5	1,9	2,4	3,0	3,4	4,7	5,9	7,4	9,6	11,8	13,9

G-a-pcv-en_a_th

The table is valid for the Hazen Williams coefficient $C=100$ (cast iron pipework);

for steel pipework, multiply the values by 1,41;

for stainless steel, copper and coated cast iron pipework, multiply the values by 1,85;

When the **equivalent pipeline length** has been determined, the flow resistance is obtained from the table of flow resistance.

The values given are guideline values which are bound to vary slightly according to the model, especially for gate valves and non-return valves, for which it is a good idea to check the values supplied by manufacturers.

FURTHER PRODUCT SELECTION AND DOCUMENTATION

Xylect



Xylect is pump solution selection software with an extensive online database of product information across the entire Lowara, and Vogel range of pumps and related products, with multiple search options and helpful project management facilities. The system holds up-to-date product information on thousands of products and accessories.

The possibility to search by applications and the detailed information output given makes it easy to make the optimal selection without having detailed knowledge about the Lowara and Vogel products.

The search can be made by:

- Application
- Product type
- Duty point

Xylect gives a detailed output:

- List with search results
- Performance curves (flow, head, power, efficiency, NPSH)
- Motor data
- Dimensional drawings
- Options
- Data sheet printouts
- Document downloads incl dxf files

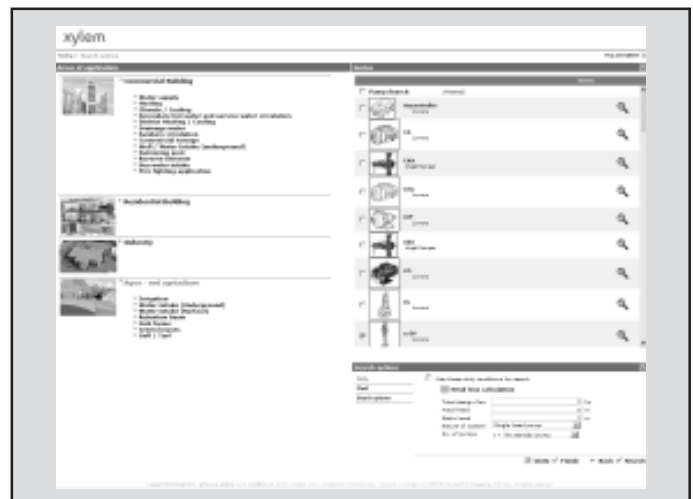

The search by application guides users not familiar with the product range to the right choice.

FURTHER PRODUCT SELECTION AND DOCUMENTATION

Xylect

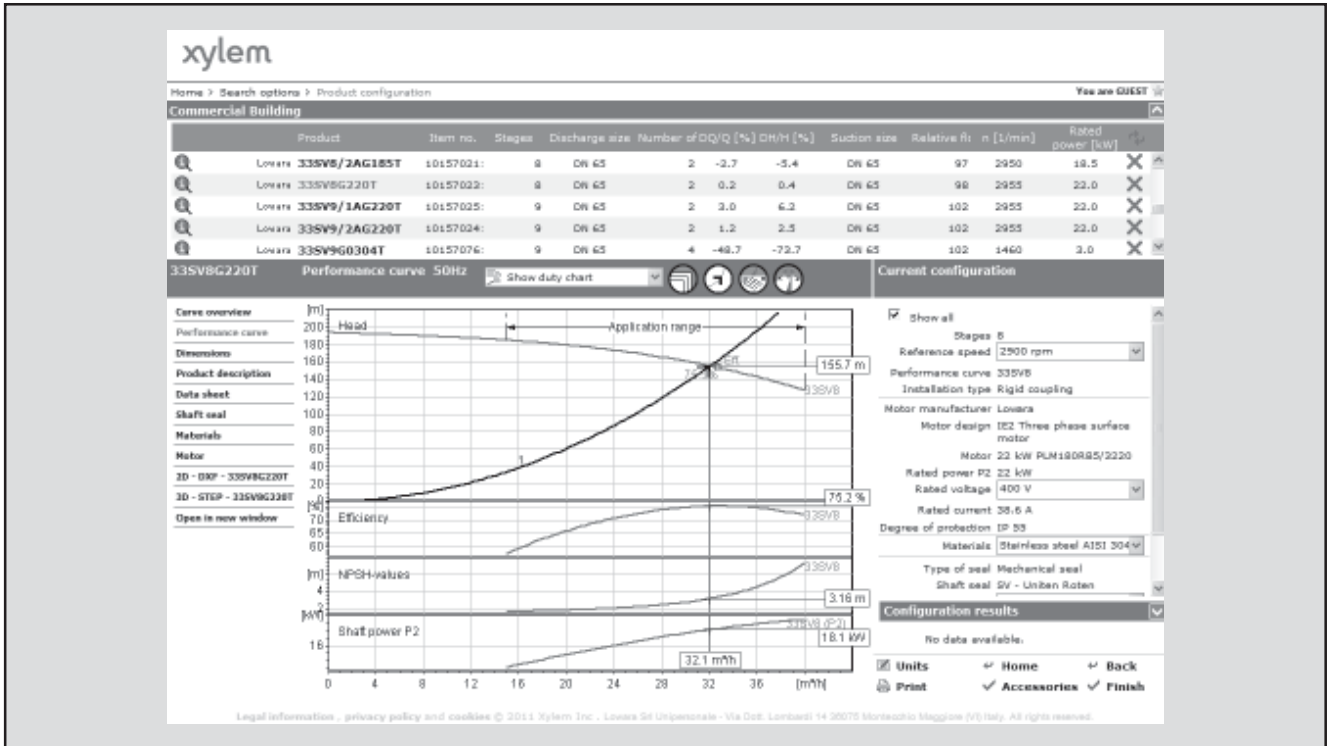

The detailed output makes it easy to select the optimal pump from the given alternatives.

The best way to work with Xylect is to create a personal account. This makes it possible to:

- Set own standard units
- Create and save projects
- Share projects with other Xylect users

Every user have a My Xylect space, where all projects are saved.

For more information about Xylect please contact our sales network or visit www.xylect.com.

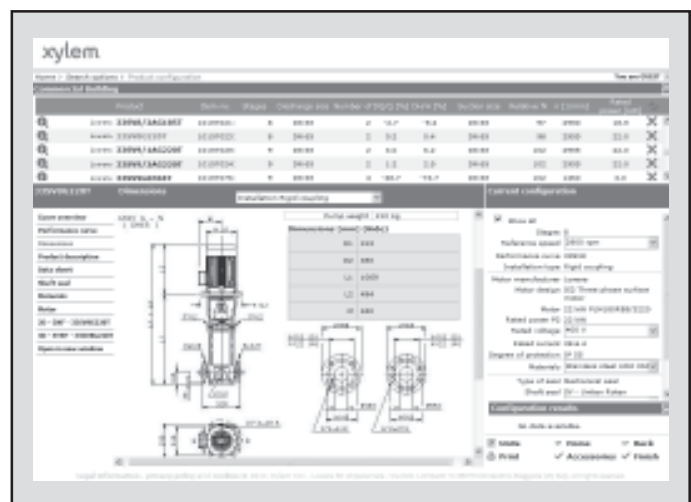

Dimensional drawings appear on the screen and can be downloaded in dxf format.

Xylem |'zīləm|

- 1) The tissue in plants that brings water upward from the roots;
- 2) a leading global water technology company.

We're 12,000 people unified in a common purpose: creating innovative solutions to meet our world's water needs. Developing new technologies that will improve the way water is used, conserved, and re-used in the future is central to our work. We move, treat, analyze, and return water to the environment, and we help people use water efficiently, in their homes, buildings, factories and farms. In more than 150 countries, we have strong, long-standing relationships with customers who know us for our powerful combination of leading product brands and applications expertise, backed by a legacy of innovation.

For more information on how Xylem can help you, go to xylem.com.



Headquarters

LOWARA S.r.l. Unipersonale
Via Vittorio Lombardi 14
36075 Montecchio Maggiore - Vicenza - Italy
Tel. (+39) 0444 707111 - Fax (+39) 0444 492166
e-mail: lowara.mkt@xylem.com
web: www.lowara.com - www.completewatersystems.com

LOWARA reserves the right to make modification without prior notice.
LOWARA is a trademark of Xylem Inc. or one of its subsidiaries.