



# e-SVI Series

IMMERSIBLE MULTISTAGE PUMPS

TAKING RELIABILITY AND PERFORMANCE TO NEW DEPTHS

# Taking reliability and performance to new depths

The e-SVI is an efficient, reliable, high-performance pump, comprised of an energy saving, vertical multistage pump coupled to a IEC high efficient motor. Plus, an immersible hydraulic end provides an ideal solution for top mount applications. Industry-leading range, with flows up to 120 m<sup>3</sup>/h and sizes from 1 to 92, meets the demands of a wide variety of applications in the industrial, OEM and commercial building services markets.

The e-SVI can be built with a variable number of stages to cover a wide range of duty points. It's configured to allow an additional number of blank stages, so that the height of the immersed part can accommodate different suction depths. It can serve as an interchangeable drop-in replacement for pumps with 3/4", 1"1/4 or 2" Rp threaded fittings, and for larger sizes, a DN80 flanged discharge connection is standard. The e-SVI is a powerful complement to the existing e-SV multistage pump family. In addition, the e-SVI can be paired with hydrovar® X to provide variable speed performance.

# A depth of knowledge, expertise and innovation

Why choose Xylem? When you choose Xylem as your pump solution partner, we offer you the support you need to build your confidence in us.

## **Pump expertise and expert advice**

Each pump is designed based on Xylem's 170-plus years of pump experience, to ensure that you always have the best solution for the job at hand.

## **Reliability and performance**

Our pump experts will ensure that your pump is optimized for your application and designed to deliver the long-lasting, reliable service that you expect.

## **Leading edge technology**

The e-SVI pump features laser-welded impellers that reduce friction and optimize pump efficiency. Sizes 1-22 feature an inducer as part of our standard offering. The inducer helps protect against dry run and allows for reliable low-level pumping. The e-SVI is available with IE5 motors and variable speed drives, providing efficiency well above a standard IE3.

## **Easy pump selection**

The online selection tool simplifies ordering, allowing you to easily configure hydraulics, pump materials, motors and seals based on your application.



# An immersible top tank solution

The e-SVI is specially designed to be mounted on the top of a tank, with the pump unit immersed in the liquid to be pumped. The length of the immersed pump unit can vary, depending on the solution your application requires.

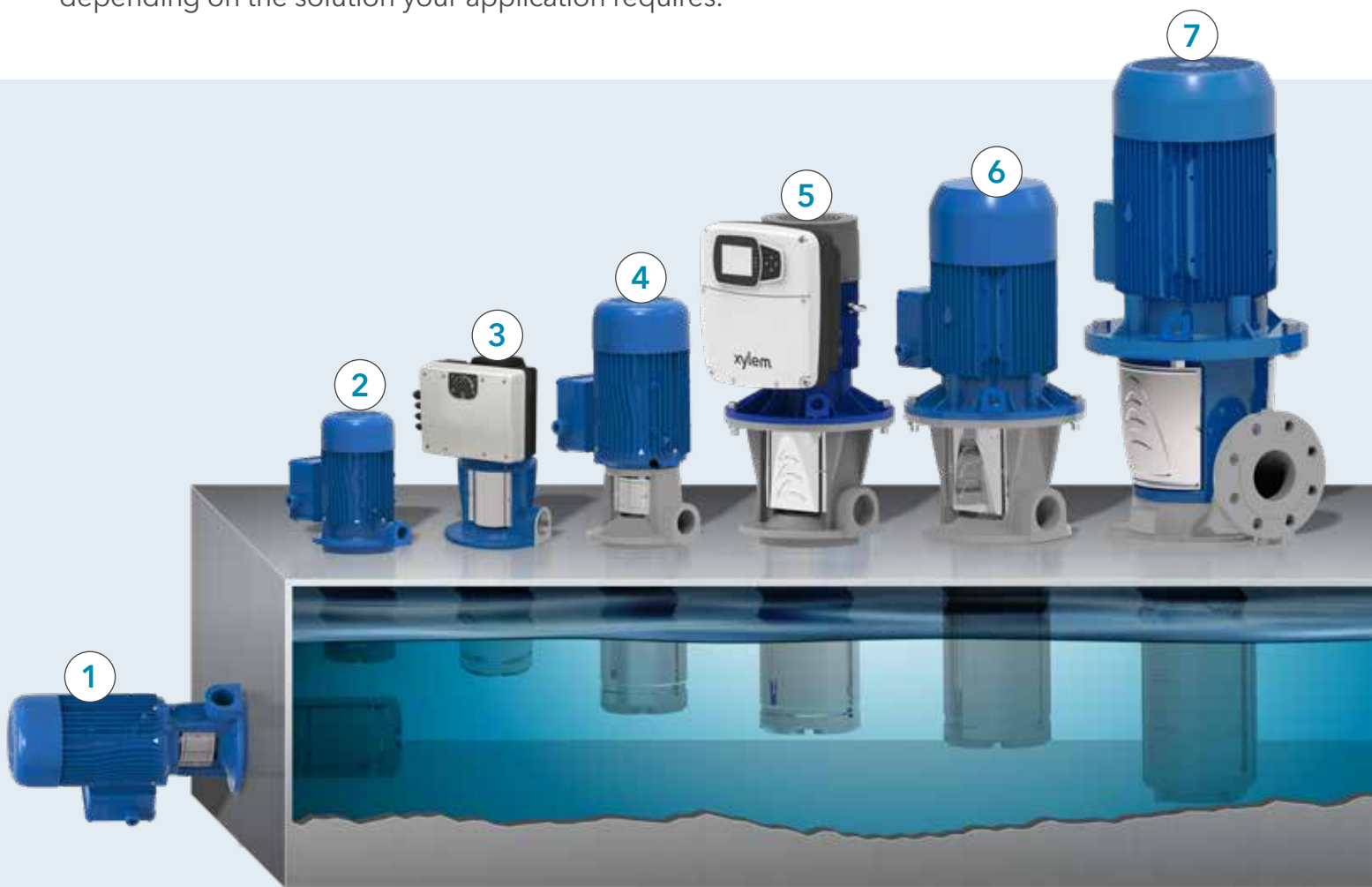

1. Sizes 1-3-5, coupled, cast iron
2. Extended shaft (close-coupled)
3. e-SVIE (with Xylem Smart Motor)
4. Sizes 1-3-5, coupled, stainless steel

5. Sizes 10-15-22, stainless steel (shown with hydrovar X)
6. Sizes 10-15-22, stainless steel
7. Sizes 33-92, stainless steel

# An abundance of features and benefits



## Performance

- Industry-leading performance and range, with flows up to 120 m<sup>3</sup>/h, meet the demands of a wide variety of applications.
- The e-SVI range 1-22 features an inducer as part of our standard offering. The inducer helps protect against dry run and allows for reliable low-level pumping.
- An assortment of materials and configurations let you create the right pump for the job at hand.
- An all-316SS version is available, to handle aggressive liquids and more demanding applications.
- A compact close-coupled option is available in three sizes, for applications with limited overhead clearance.
- A drain-back-to-tank design feature that comes standard on close coupled configurations allows pumped liquid to return to the tank, which minimizes spillover.
- The e-SVI can be built with a variable number of impellers, to cover a wide range of duty points.
- The e-SVI can be configured to allow an additional number of blank stages, so that the height of the immersed part can accommodate different suction depths.



## Reliability

- Our pump experts ensure that your pump is optimized for your application and designed to deliver the long-lasting, reliable service that you expect.
- The reduced axial thrust design makes it possible to use motors with standard bearings. This allows easy selection of standard motors reducing cost and

increasing availability.



## Efficiency

- Precision laser welded impellers reduce hydraulic losses and optimize pump efficiency.
- IEC high efficient motors, combined with the optimized hydraulic design of the e-SVI pump, reduce energy consumption and operating costs.
- Xylem hydrovar® X is available to further improve the performance of the system.



## Easy repair

- Easy-to-replace, pre-assembled cartridge seals (sizes 1-22) are available, to help ensure correct assembly.
- The mechanical seal (non-cartridge) can be replaced without removing the motor in sizes 33-92, to simplify repair and minimize downtime.
- The e-SVI is an interchangeable drop-in replacement for pumps with 3/4", 1"1/4 or 2" Rp threaded fittings, or with DN80 compatible flange discharge connections.



## Mechanical seal options

- An assortment of mechanical seals and materials are available, which are designed to handle a wide range of temperatures, high pressures and aggressive liquids with ease.



# A wide selection of mechanical seal options

The e-SVI pump is available in a wide assortment of mechanical seals designed to handle high temperatures, high pressures and aggressive liquids with ease. Durable materials prevent downtime and prolong the life of the seal.

The e-SVI pump comes standard with a durable silicon carbide/carbon seal with an FKM elastomer. This pairing enhances durability and is compatible with a wide range of applications. For more aggressive applications, select the tungsten carbide/tungsten carbide with FKM elastomer or, for other media, silicon carbide/silicon carbide with EPDM or FKM elastomer. Choose the seal option that best meets the unique demands of your application.



*Mechanical seal of close-coupled shaft*

## Easy access and repair

When it's time to repair your pump, the design of the SVI sizes 33-92 allows the mechanical seal to be removed without having to remove the motor, thus reducing repair time.

Access the standard mechanical seal without removing the motor and replace it in a few simple steps (sizes 33-92):



*Mechanical seal of SVI sizes 33-92*

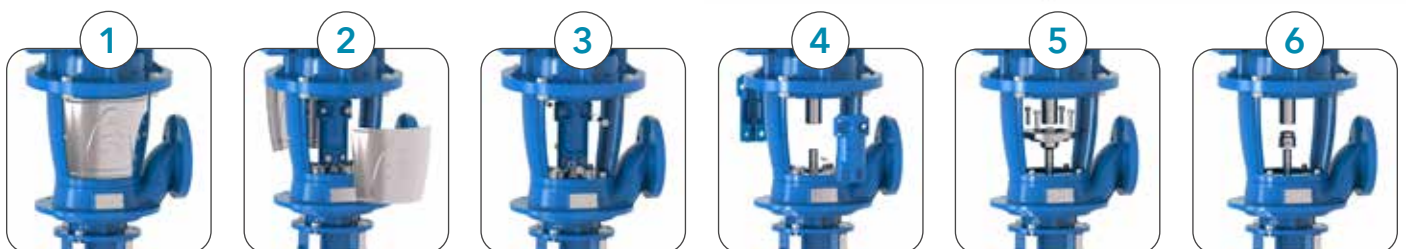

# Pre-assembled cartridge seals

An easy-to-replace pre-assembled cartridge seal configuration is available, which ensures that the seal components will never be assembled incorrectly. Our pre-assembled seal is a reliable, efficient, time-saving alternative to standard seals. It is designed for reliability and built for durability, using materials that last. The pre-assembled cartridge seal comes in a range of durable materials to meet the demands of your unique applications. The dimensions of the internal stationary and rotary parts of the seal are according to European Standard EN 12756.

## Easy repair

Once the motor is removed, the pre-assembled cartridge seal can be quickly and easily replaced in a few simple steps.



Pre-assembled cartridge seal (sizes 1-22)

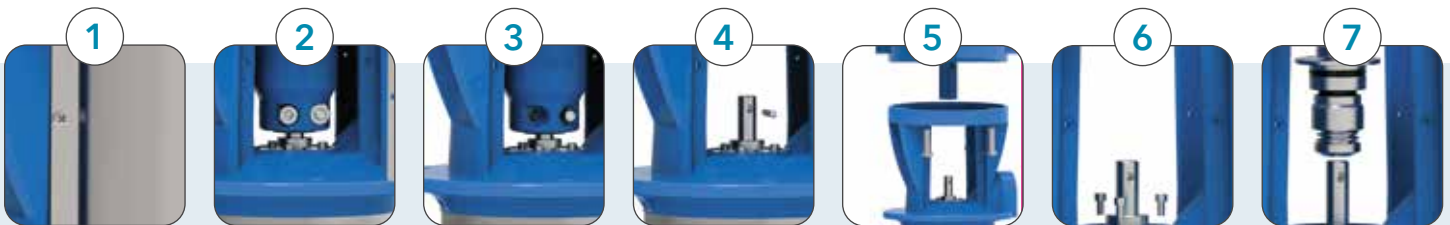

## Seal material options

### 1-3-5 e-SVI Close-Coupled

Rotating Part	Stationary Part	Elastomers	Springs	Other Components	Temperature (°C)
<b>Standard Mechanical Seal</b>					
Silicon carbide	Carbon	FKM	AISI 316	AISI 316	-10° to 60°
<b>Other Types of Mechanical Seals</b>					
Silicon carbide	Silicon carbide	EPDM	AISI 316	AISI 316	-30° to 60°
Silicon Carbide	Silicon carbide	FKM	AISI 316	AISI 316	-10° to 60°
Tungsten carbide	Tungsten carbide	FKM	AISI 316	AISI 316	-10° to 60°

### 1-22 e-SVI Coupled

Rotating Part	Stationary Part	Elastomers	Springs	Other Components	Temperature (°C)
<b>Standard Mechanical Seal</b>					
Silicon carbide	Carbon	FKM	AISI 316	AISI 316	-10° to 90
<b>Other Types of Mechanical Seals</b>					
Silicon carbide	Silicon carbide	FKM	AISI 316	AISI 316	-10° to 90
Silicon carbide	Silicon carbide	EPDM	AISI 316	AISI 316	-30° to 90°
Tungsten carbide	Tungsten carbide	FKM	AISI 316	AISI 316	-10° to 90°

## An in-depth look at the e-SVI

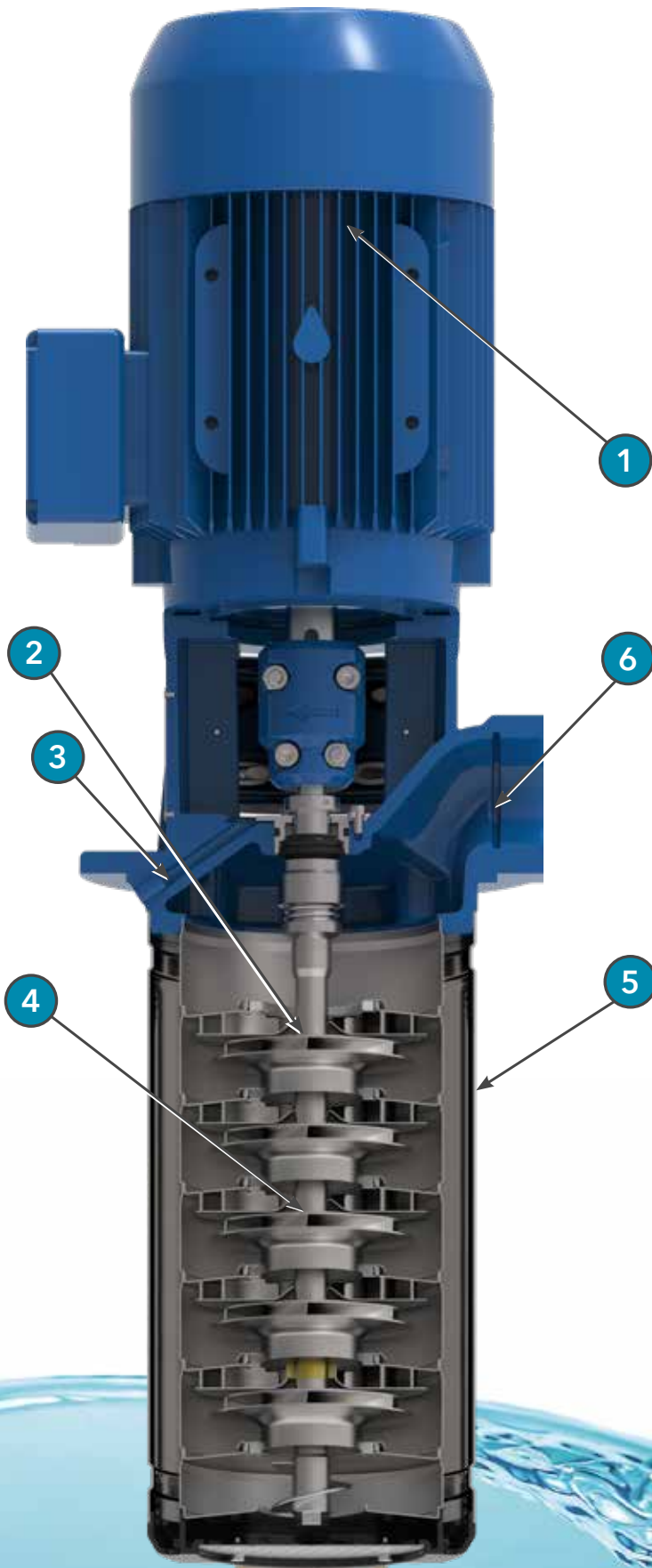

- 1. Motor** - High-efficiency motors reduce costs. IEC IE3 high efficient motors are standard on all three-phase versions above 550W. IE5 efficient Smart Motors are also available.
- 2. Wear ring** - The floating, self-aligning, glass filled, high temperature polymer diffuser wear ring withstands corrosive, aggressive and high temperature liquids, and protects against abrasion and debris.
- 3. Mechanical seal duct** - In case of leakage from the mechanical seal, this duct collects the liquid back to the storage tank to avoid stagnation and crystallization of liquid close to the mechanical seal.
- 4. Impeller design** - Reduced axial thrust design provides long bearing life with standard motors.
- 5. Casing/Tie rods** - The 316 stainless steel resists corrosion and pitting, making it durable.
- 6. Discharge connection** - This allows for easy drop-in replacement. Pumps with Rp thread sizes 1-22 are available in cast iron and stainless steel, and pumps that are compatible with DN80 flange sizes 33-92 are available in cast iron and AISI 316 stainless steel.



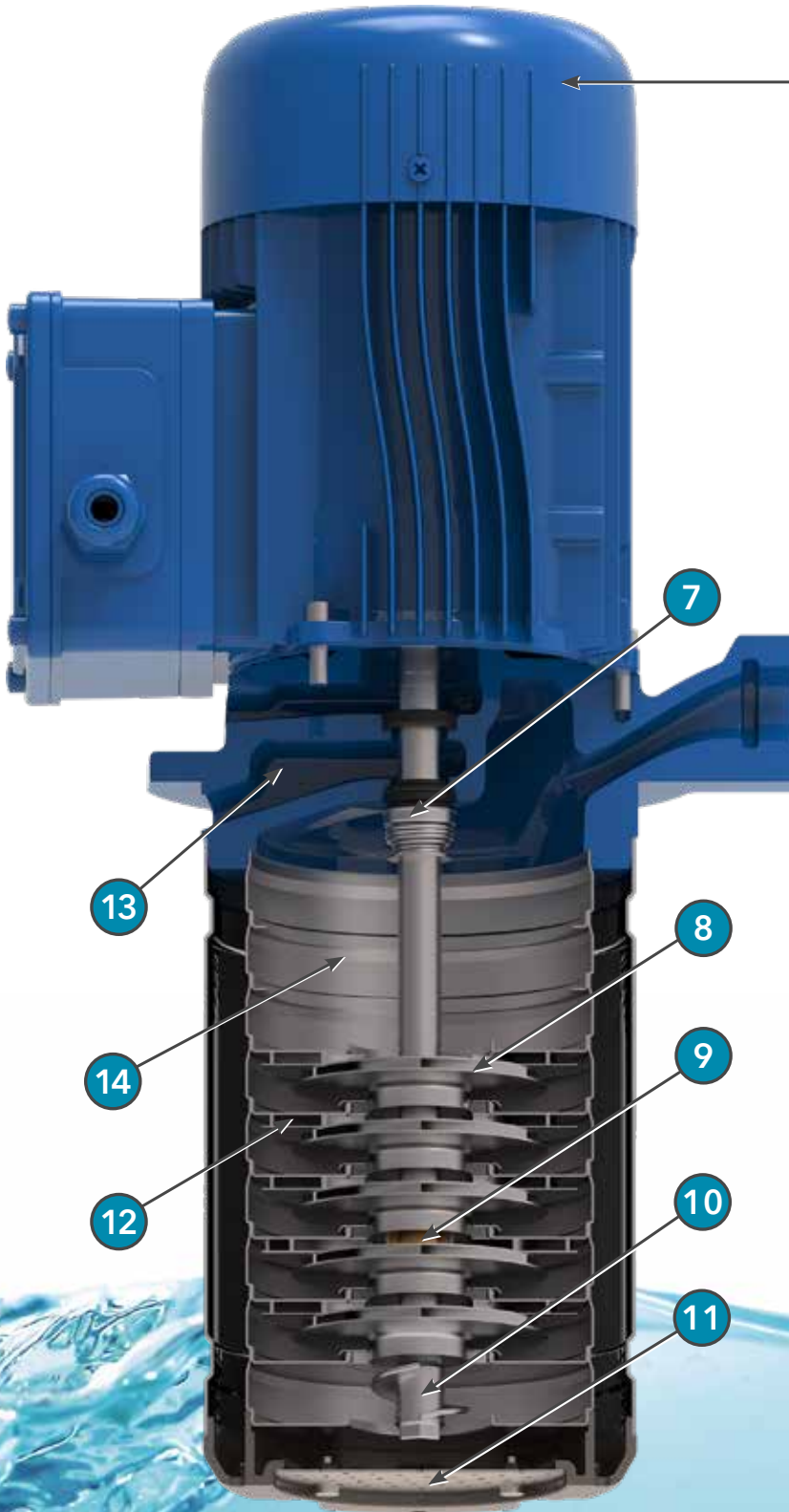

## Compact close-coupled e-SVI with IEC motor

- 7. **Mechanical seal** - An assortment of shaft seals is available, with options to handle high temperatures, high pressures and aggressive liquids.
- 8. **Impeller** - Laser-welded impellers optimize the pump's efficiency.
- 9. **Tungsten carbide bushing** - The bushing resists wear, so it can withstand heavy duty applications.
- 10. **Inducer** - An inducer is part of our standard offering on sizes 1-22. The inducer protects against dry run and allows for reliable low-level pumping.
- 11. **Inlet strainer** - The bottom suction design, with a 316 stainless steel inlet strainer, prevents unwanted particles from entering the pump.
- 12. **Variable number of impellers** - The e-SVI can employ a variable number of impellers to cover many duty points.
- 13. **Drain back to tank** - The close-coupled version has a standard design feature that minimizes spills from mechanical seal failures.
- 14. **Blank stages** - Additional blank stages can vary immersion depths to meet your application requirements.

## e-SVI series immersible multistage pumps

- Flow: up to 120 m<sup>3</sup>/h
- Head:
  - up to 250 m for sizes 1-22
  - up to 230 m for sizes 33-92
- Temperature of the pumped liquid (with a standard mechanical seal):
  - from -10 °C to +90 °C for coupled versions
  - from -10 °C to +60 °C for close-coupled version
- Discharge connections and maximum operating pressure:
  - Rp ¾ for sizes 1-3-5 close-coupled, up to PN10
  - Rp 1 ¼ for sizes 1-3-5, Rp 2 for sizes 10-15-22 coupled, up to PN25
  - Flanges for sizes 33-92, up to PN16

Published hydraulic performance is compliant with ISO 9906/HI 14.6 Grade 3B.

Direction of rotation marked with an arrow on the adapter and coupling: clockwise (looking at the pump from the top down).

## Motor

### For coupled configurations:

- IEC frame motors
- Standard voltage: see options in the nomenclature

### For close-coupled configurations:

- 2 pole motors with enclosed construction and external ventilation
- Compliant with Regulation (EC) no. 640/2009 and IEC 60034-30
- IP55 protection
- Class 155 (F) insulation
- Performances according to EN 60034-1
- Standard voltage: see options in the nomenclature
- Operating temperature:
  - Single-phase from 0 to 40°C
  - Three-phase from 0 to 55°C



### e-SVI pump coverage curves at 50 Hz

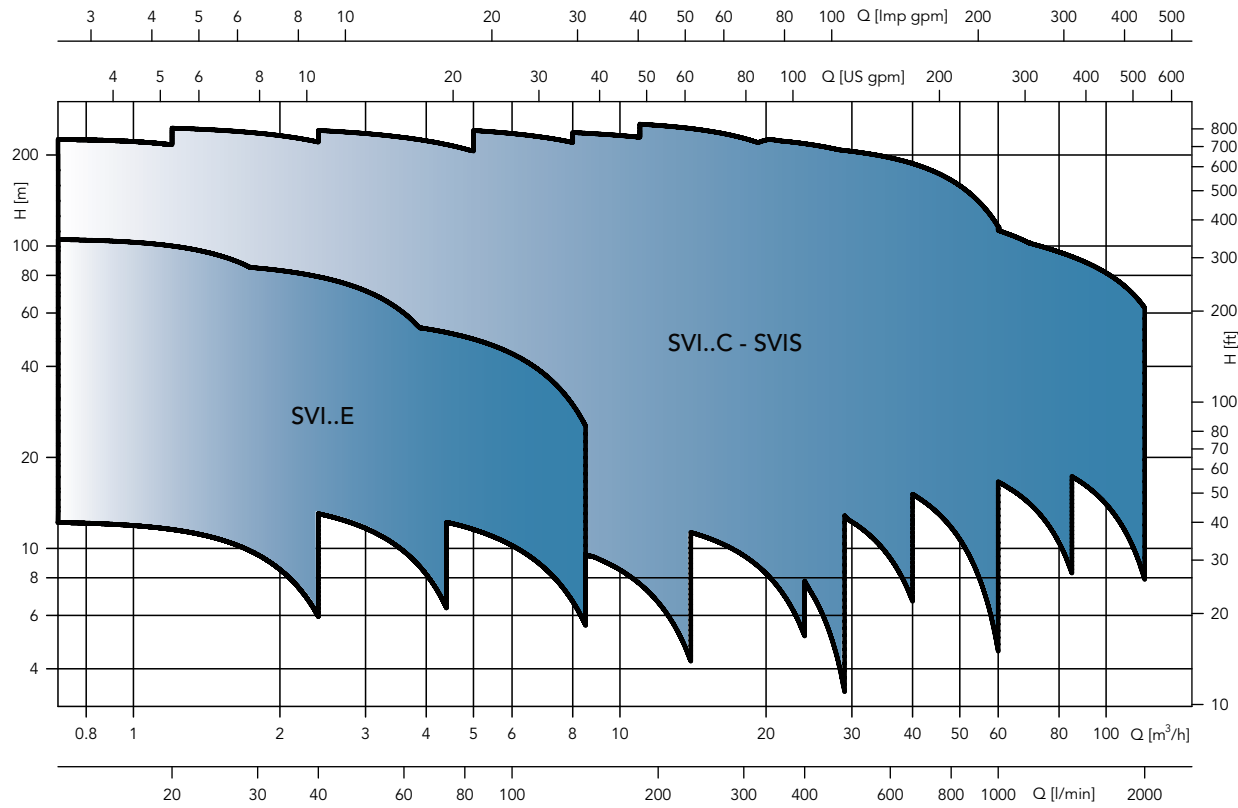

05071\_B\_CH

### e-SVI pump coverage curves at 60 Hz

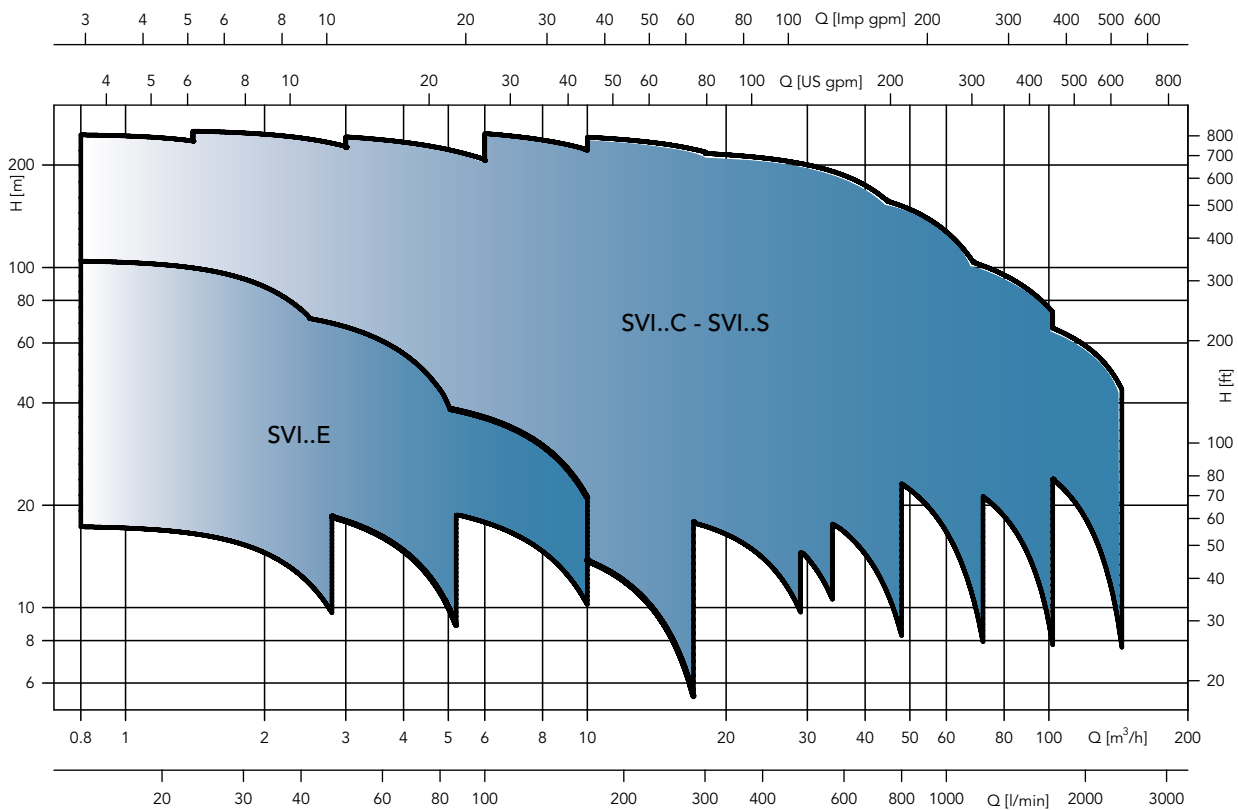

05071B\_C\_CH

# e-SVIE: stainless steel immersible multistage pumps with Xylem Smart Motor

Smart high-efficiency hydraulics yield the lowest possible operating costs for a variety of applications, including industrial, OEM, and commercial building services. The e-SVIE offers ranges with multiple construction designs. Special versions are also available.

- Features the Xylem Smart Motor, an IE5 permanent magnet motor, providing efficiency well above a standard IE3
  - Includes a wide range of monitoring, control and safety features right out of the box with no need to configure
  - Can operate single or multipump systems of up to three pumps, with no need for an external control panel or PLC
  - Exceeds hydraulic performance of fixed speed versions in a more compact design
- Designed for fast, easy maintenance with a mechanical seal
- Reduced impeller axial thrust for longer standard motor bearing life



## e-SVIE pump coverage curves at 50 and 60Hz

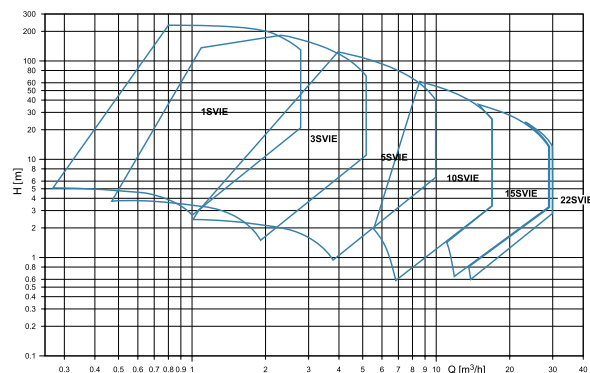

## e-SVIE specifications

Delivery: Up to 19 m<sup>3</sup>/h

Head: Up to 215 m

Temperature of the pumped liquid (with standard mechanical seal):

- from -10 °C to +90 °C for coupled versions
- from -10°C to +60 °C for close-coupled version
- extendible up to 120 °C with special mechanical seals

Discharge connections and maximum operating pressure:

- Rp 3/4" for sizes 1-3-5 close-coupled: up to PN10
- Rp 1 1/4 for sizes 1-5, Rp 2 for sizes 10-22 coupled: up to PN25

Published hydraulic performance is compliant to ISO 9906 Grade 3B

# e-SVIX: stainless steel immersible pump with hydrovar® X

Industrial applications that demand the reliability of e-SVI multistage pumps are taken to new levels with hydrovar® X - with intelligent pump management and connectivity that offers maximum uptime and precision performance.

hydrovar® X brings the best energy efficiency performances with its frequency converter coupled with the ultimate synchronous motor, manufactured by Xylem integrating decades of expertise and know-how in pumping solutions.

It's the right combination of motors, variable speed drive and pump ensuring great performance, maximum savings and a rapid return on investment.

	HVX	HVX +
<b>Display</b>	LED	Graphic color
<b>Controls</b>		
Pressure	•	•
Flow		•
Temperature		•
Level		•
<b>Multi-Pump</b>	Up to 4 pumps	Up to 8 pumps
<b>Extended I/Os</b>		•

## Performance curve

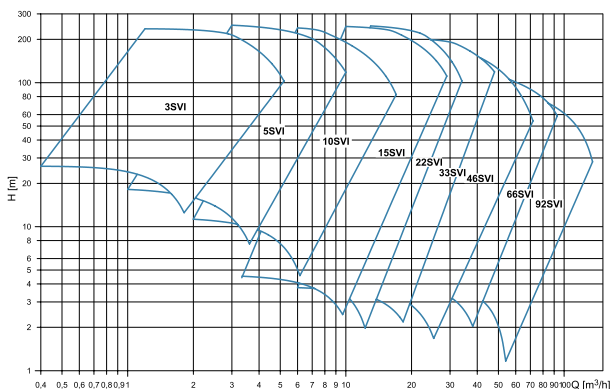

- IE5 Permanent magnet assisted reluctance motor equipped with advance control for the highest efficiency level and to extend the lifetime of the motor
- Multipump capability as standard with no single failure point
- Remote control and management via app



## Specifications

Flow rate: up to 135 m<sup>3</sup>/h

Head: up to 260 m

Temperature of pumped liquid: up to +120°C

Maximum operating pressure 25 bar (PN 25)

The hydraulic performances meet the tolerances specified in ISO 9906:2012

Environment temperature: -20° C to +50° C with no performance derating



# Xylem Hydrovar® pump mounted variable speed controller

Hydrovar is the intelligent pump controller that matches performance to system demand. Xylem Hydrovar is efficient and easy to install and operate, making it the ideal variable speed controller for new and retrofit applications. The Hydrovar controller works with any standard AC motor and can be direct mounted or wall mounted. The built-in application software makes it one of the easiest drives to commission, program and operate, enabling virtually any configuration of pumps.



## Features

- Easy to setup and commission
- Energy savings (up to 70%)
- Large LCD display
- Pre-programming for standard motors
- 28 language sets
- Advanced motor control to reduce heating and extend the lifetime of the motor
- Embedded THDi filter for better electricity quality from the grid, extending the life of the equipment
- Standard multi-pump capability of up to eight (8) pumps with no single failure point
- Premium card option for extended I/O
- Backward compatibility to existing Hydrovar products
- BACnet and Modbus as a standard for seamless BMS integration

## Specifications

Input supply (from 1,5 kW to 22 kW): Single phase 208-240 V  $\pm$  10%, 1,5-4 kW, 50 or 60 Hz  
Three phase 208-240 V  $\pm$  10%, 1,5-11 kW, 50 or 60 Hz  
Three phase 380-460 V  $\pm$  10%, 1,5-22 kW, 50 or 60 Hz

---

Output frequency: From 30-60 Hz

---

EMC class: Three phase C2, single phase C1

---

Maximum ambient temperature: 40 °C

---

Enclosure rating: IP55

---

Communication: RS485 interface, BACnet, Modbus

---

# Applications

## Typical applications

Designed with flexibility and reliability in mind, e-SVI immersible multistage pumps are the ideal choice for top mount tank applications. The pump design is an effective solution to many needs in the industrial, OEM and commercial building services markets, and covers a wide variety of applications.

### INDUSTRIAL



- Cooling and tool lubrication circuits
- Cooling systems
- Machine tooling
- Process temperature control
- Industrial washing systems (degreasing of mechanical components)
- Pressurization of clean liquids
- Transfer of condensation
- Filtering systems (reverse osmosis)
- Heat exchange
- Washing and cleaning systems (washing wells, and washing cars and trucks)
- Electronics circuit washing
- Commercial washing machines

### OEM



## Pumped liquids

- Cooling and lubricating fluids
- Emulsions
- Cutting, hydraulic and motor oil
- Condensation
- Water with detergents
- Desalinated water
- Water and glycol



# Xylem |'zīləm|

- 1) The tissue in plants that brings water upward from the roots;
- 2) a leading global water technology company.

We're a global team unified in a common purpose: creating advanced technology solutions to the world's water challenges. Developing new technologies that will improve the way water is used, conserved, and re-used in the future is central to our work. Our products and services move, treat, analyze, monitor and return water to the environment, in public utility, industrial, residential and commercial building services settings. Xylem also provides a leading portfolio of smart metering, network technologies and advanced analytics solutions for water, electric and gas utilities. In more than 150 countries, we have strong, long-standing relationships with customers who know us for our powerful combination of leading product brands and applications expertise with a strong focus on developing comprehensive, sustainable solutions.

**For more information on how Xylem can help you, go to [www.xylem.com](http://www.xylem.com)**



[www.xylem.com/lowara](http://www.xylem.com/lowara)

Xylem reserves the right to make modification without prior notice.  
Lowara, Xylem and hydrovar are trademarks of Xylem Inc. or one of its subsidiaries.  
© 2023 Xylem, Inc. - P05/23