



e-SV™ Series

STAINLESS STEEL VERTICAL MULTISTAGE PUMPS

DESIGNED FOR EFFICIENCY. BUILT FOR PERFORMANCE.

Where efficiency meets performance

The e-SV fabricated vertical multistage pump is an energy saving, non-priming pump coupled to a standard premium-efficient motor. It's built to withstand a variety of mechanically aggressive and high temperature liquids, and is designed to extend uptime and help reduce lifecycle costs in a wide range of demanding applications.

The e-SV range of pumps features 11 models, and each can be specially configured for a wide range of environments. What's more, when an e-SV is paired with a AQUAVAR® IPC variable speed drive, it provides energy saving increases up to 70% vs. fixed speed, while reducing installation time.

Also available in pre-programmed, pre-assembled packages, the e-SVE Smart Pump, hydrovar® X and hydrovar® classic, are complete systems, delivering market-leading efficiency and performance right out of the box.



**POWER
GENERATION**



OIL & GAS



**GENERAL
MANUFACTURING**



POOL & LEISURE



MINING



WATER UTILITIES

extra efficient

The e-SV's hydraulics, combined with a high-efficiency motor (IE3, IE4 or IE5) deliver maximum efficiency.

energy saving

Pumps are among the largest users of industrial energy. Do your part to reduce CO₂ emissions and your impact on the environment - and improve your bottom line - by taking advantage of the e-SV's lower energy requirement. Use a e-SV hydrovar® X and a e-SV SMART and save even more energy.

easy to maintain

The e-SV's design allows removal of the mechanical seal without having to remove the motor*, reducing repair time by up to 50%. A standard mechanical seal, wearing components, service tools and standard IEC motors enable faster and easier maintenance and servicing.

*as standard for e-SV 33-125 (all motor sizes) and and e-SV 1-22 with motor sizes IEC132 and above.

On request on e-SV 1-22 with motor sizes IEC90 to112.



Broad range of solutions delivering market-leading efficiency and performance



e-SV X
e-SV hydrovar® X+



e-SVE
Smart e-SV



e-SV



AQUAVAR IPC



HYDROVAR® Classic



e-SVH
Packaged HYDROVAR®

The e-SV pump

The e-SV pump, the product at the heart of the e-SV Series, is one of the highest efficiency multistage pumps on the market today. This fabricated vertical multistage pump is also easy to install and economical to maintain. When it comes to efficiency, the e-SV delivers.



Benefits

- The expanded hydraulic coverage of an e-SV pump combined with a high-efficient motor delivers maximum performance.
- The extended e-SV portfolio allows you to select a pump aligned with your application's optimum duty point.
- A variable speed version such as e-SV hydrovar® X, e-SV hydrovar® X+, e-SV SMART or AQUAVAR IPC increases an e-SV's energy savings up to 70% vs. fixed speed while reducing installation time.
- Standard models offer low NPSH, with even lower NPSH models available.
- e-SV pumps are available in horizontal and vertical configurations.
- You can choose the flange orientation or type to meet your piping needs.
- The mechanical seal can be replaced quickly and easily, reducing repair time by up to 50%.
- The pump can be easily repaired right in the piping.
- The O-ring seat is designed to allow easy outer sleeve disassembly.
- The standard mechanical seal, wearing components, service tools and IEC motors enable faster, easier maintenance and servicing.
- To simplify maintenance, a repair stack assembly is available for quick and efficient installation and repair.

Specifications.

Delivery	up to 160 m ³ /h
Head	up to 330 m
Power supply	three-phase and single-phase 50 and 60 Hz
Power	standard motors from 0.37 kW to 55 kW
Maximum operating pressure	PN25-40 for sizes 1-22SV; PN16, PN25, PN40 for sizes 33-125
Temperature of pumped liquid	-30°C to +120°C standard version
Protection	IP55
Variable speed (on pumps and Booster Packages)	Smart version with IE5 permanent magnet motor and embedded drive; e-SV X and X+ version with IE5 assistance reluctance motor and embedded drive

Special versions.

Low NPSH
High Pressure up to 40 bars
High Temperature up to 150 and 180°C
Passivated and Electropolished
Horizontal installation
Space saving
Round flanges, discharge port above suction

Built to perform

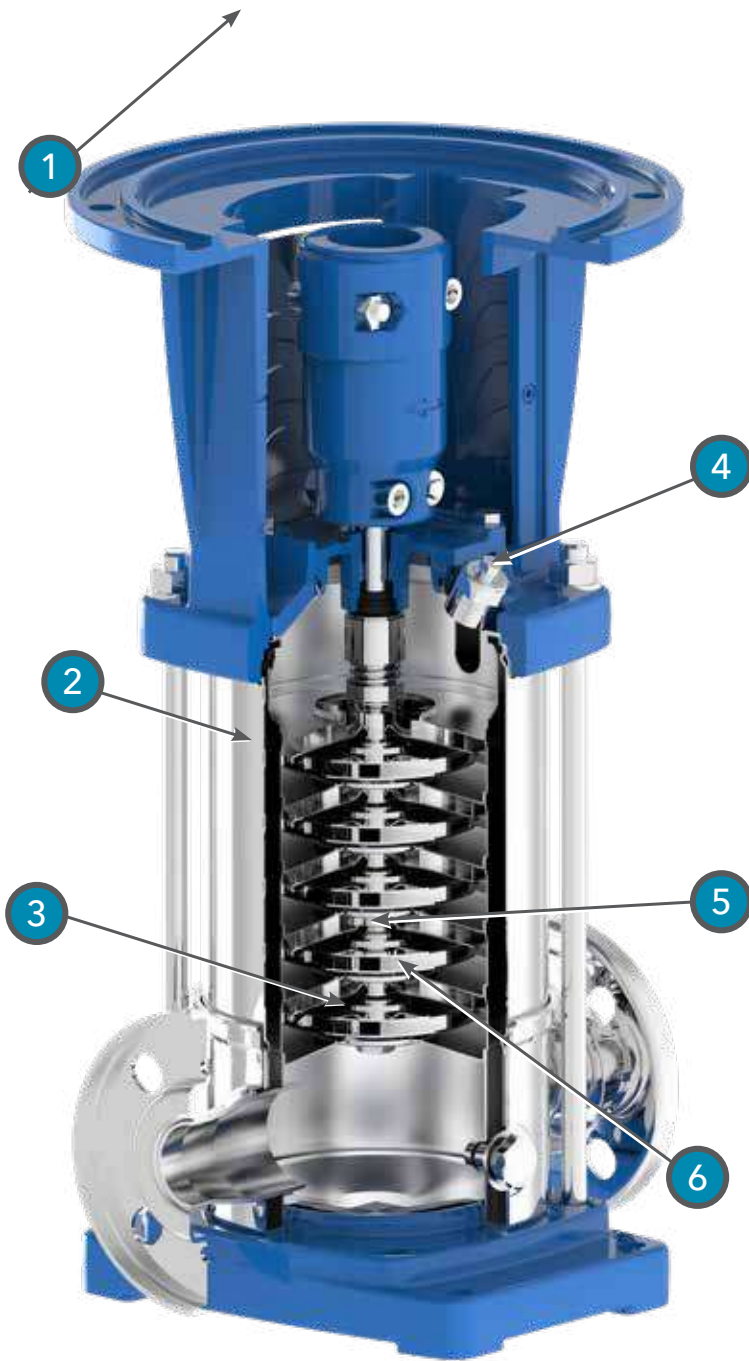

- 1. Motor (Not shown)** - Standard e-SV high efficiency motors range from 300W to 55kW. The e-SVE feature the Xylem Smart Motor, and e-SVX uses permanent magnet assisted reluctance motors, both e-SV, e-SVX an "ultra premium" (IE5) motor.
- 2. Casing** - The stainless steel casing provides durability and long life. Single and double sleeve options are available. They are compatible with high pressure applications such as pressure boosting.
- 3. Wear ring** - The floating, self-aligning, glass filled, high temperature polymer diffuser wear ring withstands corrosive, aggressive and high temperature liquids. It protects against abrasion and debris for reliable, long lasting performance.
- 4. Plugs** - Top fill plugs with air vents allow for easy installation and removal of trapped air in the seal housing. These are available on all models.
- 5. Bearings** - The tungsten carbide intermediate bushing improves longevity, reliability and the ability to withstand heavy duty applications such as boiler feeding.
- 6. Impeller** - The balanced impeller design reduces axial thrust for long standard motor bearing life.
- 7. Tie rods** - The liquid end is held in place by tie rods, for increased stability.

Top fill plugs with air vents available for all models.

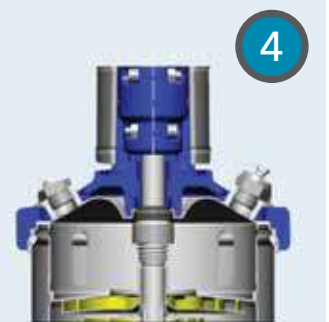

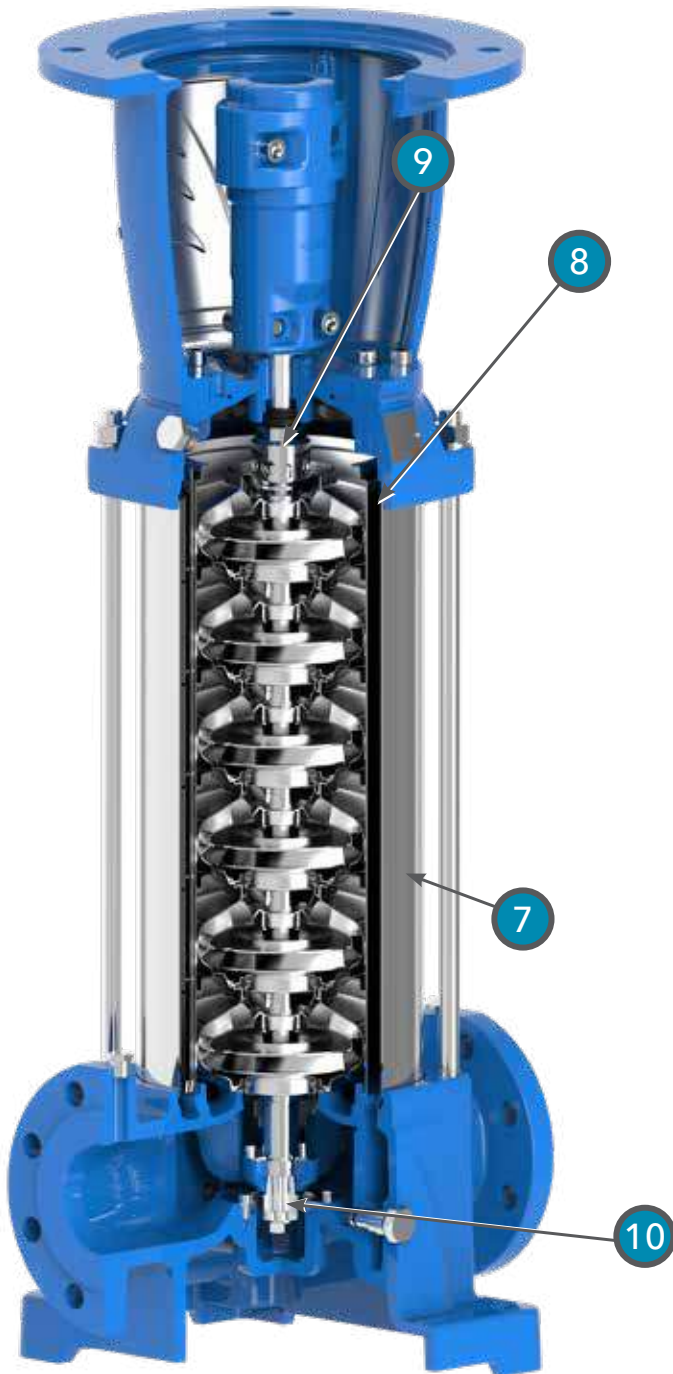

8. O-ring - The seat design provides easy access and disassembly.

9. Mechanical seal - The seal is easy to replace without removing the motor*. Robust seal options are available in a wide range of types and materials, to resist corrosion and minimize downtime in industrial and commercial building applications.

* as standard for e-SV 33-125 (all motor sizes) and e-SV 1-22 with motor sizes IEC132 and above.
On request on e-SV 1-22 with motor sizes IEC90 to 112.

10. Thrust balancing piston - The thrust balancing piston reduces axial thrust for long standard motor bearing life.

5

Tungsten carbide bush bearing to improve life and ability to withstand heavy duty applications, like boiler feeding.

6

Balanced impeller design reduces axial thrust for longer standard motor bearing life.

Performance curves

e-SV 50 Hz fixed speed performance curves

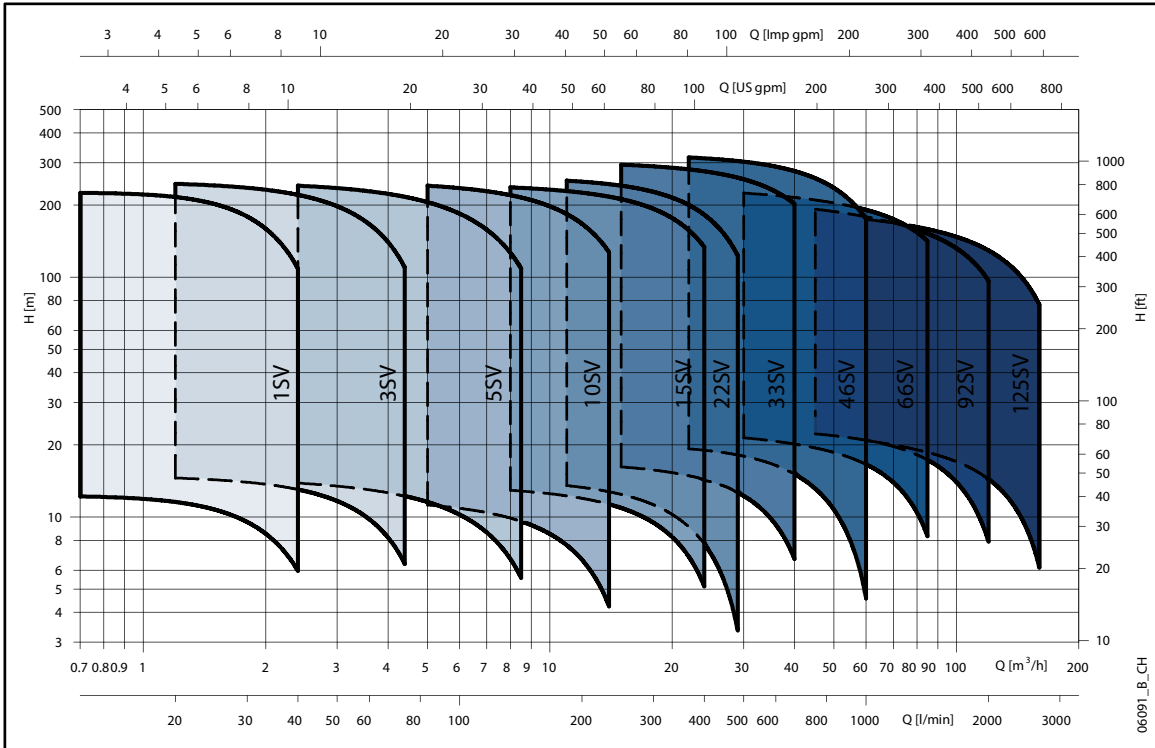

e-SV 60 Hz fixed speed performance curves

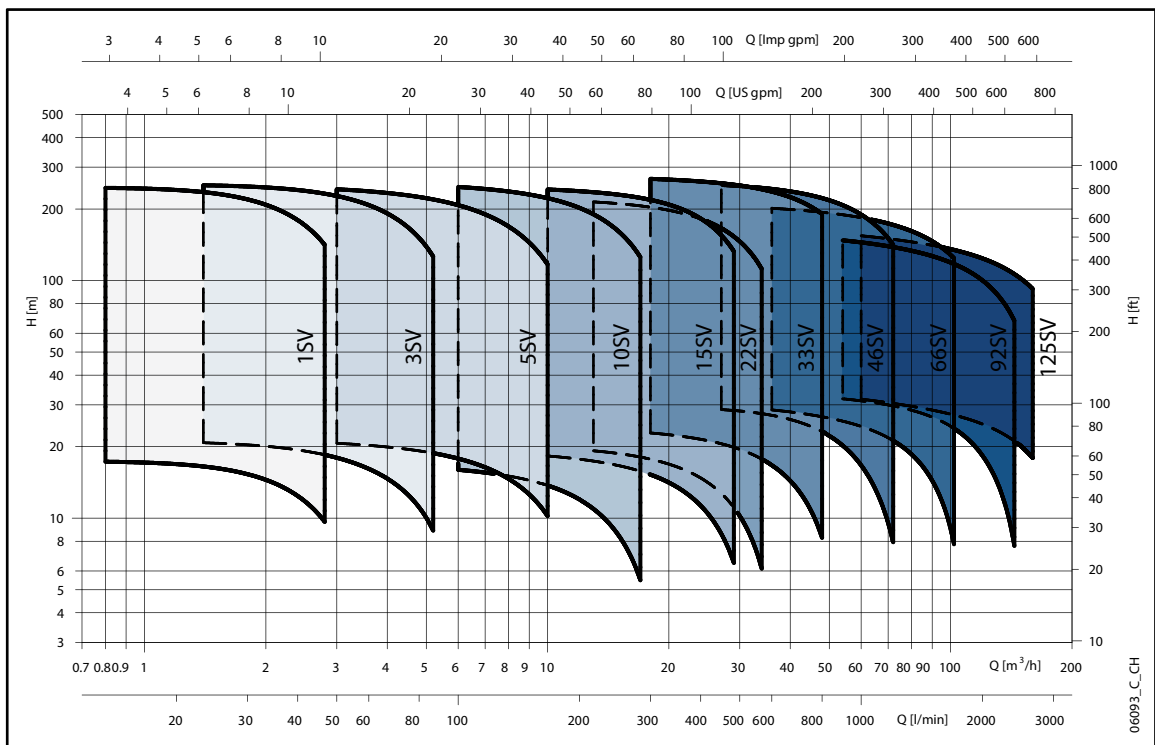

Applications

e-SV multistage pumps have a history of performance handling water and liquids such as glycol, oils/solvents, and more in the industrial, municipal, commercial building services and agricultural markets. Some of the many applications include:

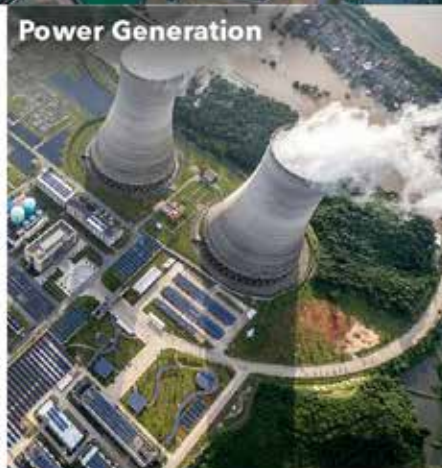

And more

- Ultra-filtration systems
- Reverse osmosis systems
- Purification
- Water softeners and de-mineralization
- Distillation systems
- Booster systems
- Water transport/treatment systems
- Cooling and heating systems
- Potable water
- Firefighting system
- Commercial washers
- Washing and cleaning systems
- Process cooling and heating
- Machine tool cooling
- Electronics cooling
- Industrial fluid transfer and transport
- Heat transfer fluids
- Sprinkler systems
- Boiler feed
- Humidifiers

e-SVE: e-SV with integrated Xylem Smart Motor

Smart high-efficiency hydraulics yield the lowest possible operating costs for a variety of applications, including residential and light commercial, OEM applications and HVAC. Six ranges offer multiple construction designs, with special versions available.



- IES2 drive with permanent magnet motor for top efficiency
- More compact than the fixed-speed version, meeting the same duty points with precision and consistency
- A variety of connections (threaded, round, clam and oval flanges, Victaulic) configured vertically; ports can be on the same side to save space
- Designed for fast, easy maintenance with a balanced mechanical seal, an O-ring seat design and a replaceable diffuser wear ring
- Reduced impeller axial thrust for longer standard motor bearing life
- Certified for drinking water use (WRAS and ACS)
- Options include high-temperature seals, low NPSH design, high pressure design, and passivated and electropolished versions

Specifications

Delivery	up to 30m ³ /h
Head	up to 235m
Liquid temperature	up to 120°C
Pressure	PN25
Power range	0.37-2.2 kW

Performance Curve

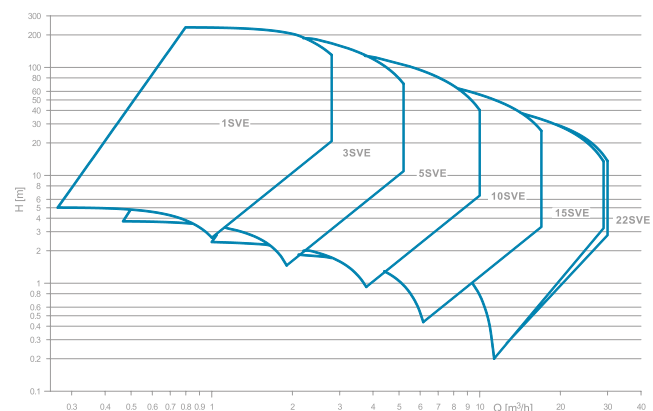

e-SVX: e-SV with hydrovar® X

Take the efficiency and low lifetime costs of e-SV multistage pumps to new levels with hydrovar® X - first-class pump management that optimises connectivity, sustainability and performance.

hydrovar® X brings the best energy efficiency performances with its frequency converter coupled with the ultimate synchronous motor, manufactured by Xylem integrating decades of expertise and know-how in pumping solutions.

It's the right combination of motors, variable speed drive and pump ensuring great performance, maximum savings and a rapid return on investment.

- IE5 Permanent magnet assisted reluctance motor equipped with advance control for the highest efficiency level and to extend the lifetime of the motor
- Multipump capability as standard with no single failure point
- Remote control and management via app



	HVX	HVX +
Display	LED	Graphic color
Controls		
Pressure	•	•
Flow		•
Temperature		•
Level		•
Multi-Pump	Up to 4 pumps	Up to 8 pumps
Extended I/Os		•

Specifications

Flow rate	up to 160 m ³ /h
Head	up to 260 m
Temperature of pumped liquid	up to +120°C
Maximum operating pressure	PN16, PN25, PN40
The hydraulic performances meet the tolerances specified in ISO 9906	2012
Environment temperature	-20° C to +50° C with no performance derating

Performance Curve

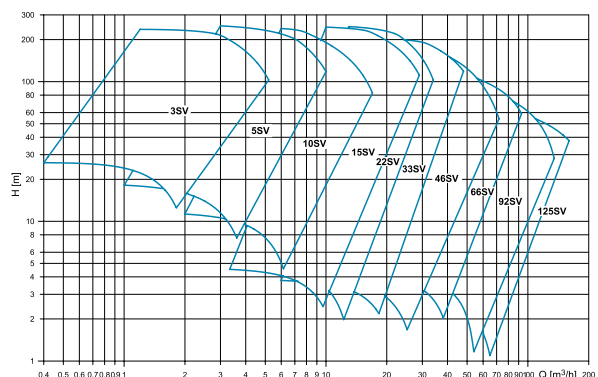

e-SV Special versions

Xylem has developed a wide range of special versions to give an appropriate and dedicated solution to special applications and installations in the industry or in the building services market:

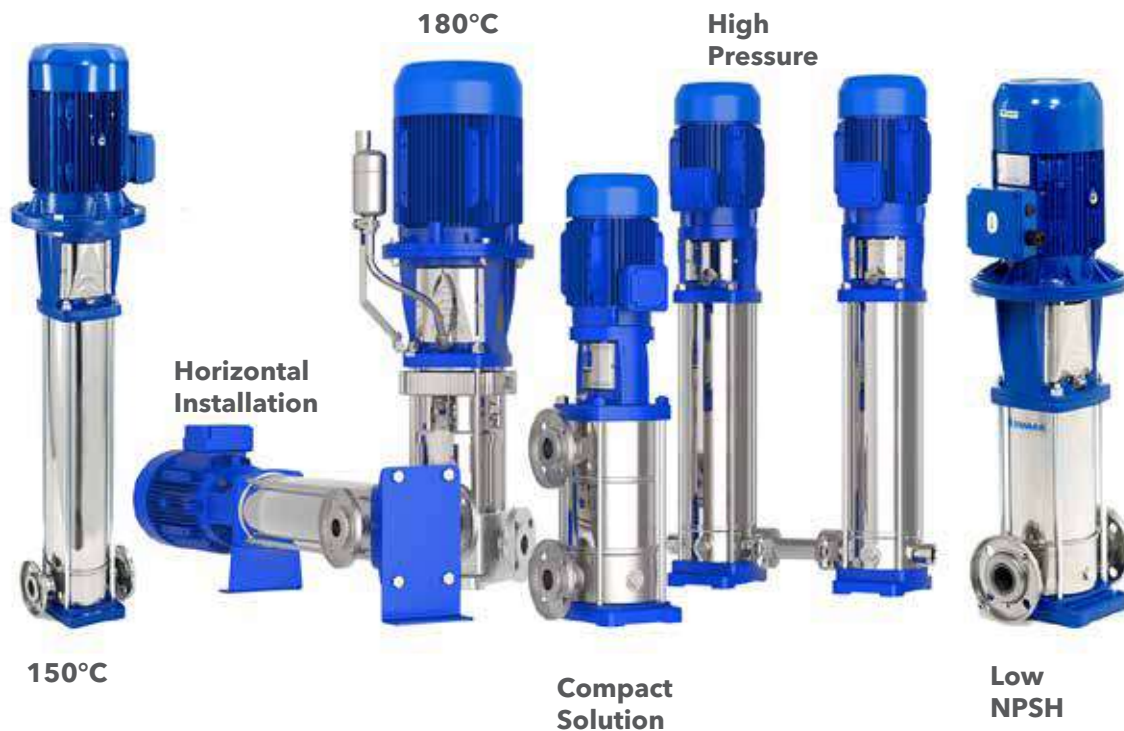

High Pressure

e-SV High Pressure is available in two different configurations: single pump solution or tandem pump solution (two pumps in series). If the inlet pressure value is already high, Lowara delivers a single pump able to withstand the high inlet pressure and deliver up to 40 bar pressure at the outlet.

The specific balanced mechanical seal, the particular design of the sleeve, the balanced design of the

Low NPSH

In industrial applications, often pumps are exposed to heavy duty installations and conditions, such as pumping high temperature liquids (boiler-feed), poor inlet pressure conditions or high flow rate applications. In these cases, constant and durable pump operation is often compromised by cavitation.

The special design of the first initial stage, together with a specific impeller design, allows e-SV Low NPSH versions to improve its suction capacity and

impeller and the hard material intermediate bush bearing allow e-SV withstanding up to 40 bar without stressing the motor and the pump components, with a direct consequence on the reduction of the life cycle cost.

e-SV High Pressure in tandem system is composed of two identical standard e-SV High Pressure pumps, making replacement easy and cost-effective.

even in critical suction conditions, the pump is able to deliver consistent and constant operation on the whole application range without any tank or additional accessories on the suction side.

This specific design saves the pump of the cavitation: the components in the pump are not submitted to stress, decreasing the need of repetitive maintenance and reducing the life cycle cost of the pump.

150°C

Thanks to the special design of its housing, the normalized seal is protected from the stress caused by high temperatures by means of a "natural" lubrication process which is triggered by the pumped liquid itself. Furthermore, the balanced mechanical seal and the high quality of the elastomers assure excellent long-term performance, even in the harshest operating conditions.

180°C

Thanks to the special design of its housing, the seal is protected from the stress caused by high temperatures by means of a "natural" lubrication process which is triggered by the pumped liquid itself, and a cooling system which uses the air in the room. A degasser is also installed at the top of the pump in order to automatically eliminate the air in the seal area. The temperature decreased to 100°C in the mechanical seal area, together with the balanced mechanical seal,

4-pole motors

By reducing the speed of the pump by 50% allows delivering very quiet operation.

At low speeds, the bearings experience less friction and wear, which can extend their lifespan, which in turn will reduce maintenance costs and downtime.

e-SV 4 pole combined with HYDROVAR, the variable

Compact Solution

e-SV Reduced dimensions offers up to 50% saving in the plant room dedicated usually for a traditional vertical multistage pump with suction and discharge ports designed inline. This specific design of the pump allows installing e-SV Reduced dimensions everywhere, even at a close proximity to a wall.

Horizontal Installation

In some applications where room is reduced vertically, it is mandatory to have some pumps systems able to deliver high pressure performances together with a limited occupied vertical space.

e-SV 150°C pumps are hardwearing thanks to the hard metal bush supports which can withstand high temperature applications up to 150°C and pressure values up to 25 bar. e-SV 150°C pumps use a standard balanced mechanical seal (EN12756) which makes it cheap and easy to replace.

pump body and upper chamber in cast AISI 316, hard metal bush supports, double outer jacket and the high quality of the elastomers of the e-SV 180°C pump, assure excellent long-term performance, even in the harshest operating conditions.

e-SV 180°C pumps are designed to operate in any application at temperatures up to 180°C and pressures up to 25 bar.

speed driver developed by Lowara, allows an additional reduction of the noise of the pumping system.

HYDROVAR, by smoothing the ramping up and down of the pump, reduces the speed of the water in the piping and as a consequence the noise made by the full installation.

e-SV Reduced dimensions offers many different configurations with the delivery port above the suction port with 4 adjustable positions.

e-SV Reduced dimensions is available with round flanges up to PN25.

Any e-SV pumps can be installed in a horizontal position thanks to a specific range of accessories developed by Lowara.

Make your e-SV even more efficient

There are significant opportunities to reduce a pumping system's energy consumption, including smart hydraulic system design, efficient operating practices, and retrofitting for variable speed performance. To build and operate an efficient water system, you need both the right products and experts who know the application.

HYDROVAR and AQUAVAR IPC controllers were designed by Xylem's engineers with these things in mind. They incorporate built-in pump protection controls and monitoring, to help you optimize your pump operations. What's more, when combined with efficient e-SV Series pumps, they increase your energy savings up to 70% vs. fixed speed while reducing installation time.

AQUAVAR® IPC variable speed controller



Features

- The Start-Up Genie makes start-up and programming easy.
- A wide range of standard and permanent magnet motors provide power 90kW.
- AQUAVAR can control up to four pumps, with no need for a programmable logic controller.
- It can be commissioned and monitored remotely, and includes USB connectivity and software.
- The two-wire multi-pump connection makes installation quick and easy.
- Hand on, off, and auto-on buttons are available for easy pump operation at the keypad. No need to toggle between local and remote operation.
- It includes system redundancy with multi-master control, in case of drive failure.
- BACnet and MODBUS are standard, for seamless BMS integration.

Specifications

Enclosures	IP66
Frame size	18 sizes, from 1.1 kW to 90 kW
Ambient temperature	-10°C - 45°C; Higher temperatures can be achieved by derating the output amperage of the drive 10% for up to 50°C
Communication	MODBUS® RTU and BACnet standard.
Relative humidity	Lower than 95% without condensation
Altitudes	From 0 to 1000 meters. Derate for altitudes above 1000 meters with a maximum operating altitude of 3000 meters. Consult factory for applications above 3000 meters.
Electrical - input power	3 phase 380 V to 480 V ±10% 3 phase 200 V to 240 V ±10% 3 phase 525 V to 600 V ±10% 3 phase 525 V to 690 V ±10% Frequency 50 or 60 Hz, ±2Hz
Electrical - output power	3 phase from 0 to V supply

Xylem Hydrovar® pump mounted variable speed controller

Hydrovar is the intelligent pump controller that matches performance to system demand. Xylem Hydrovar is efficient and easy to install and operate, making it the ideal variable speed controller for new and retrofit applications. The Hydrovar controller works with any standard AC motor and can be direct mounted or wall mounted. The built-in application software makes it one of the easiest drives to commission, program and operate, enabling virtually any configuration of pumps.



Features

- Easy to setup and commission
- Energy savings (up to 70%)
- Large LCD display
- Pre-programming for standard motors
- 28 language sets
- Advanced motor control to reduce heating and extend the lifetime of the motor
- Embedded THDi filter for better electricity quality from the grid, extending the life of the equipment
- Standard multi-pump capability of up to eight (8) pumps with no single failure point
- Premium card option for extended I/O
- Backward compatibility to existing Hydrovar products
- BACnet and Modbus as a standard for seamless BMS integration

Specifications

Input supply (from 1,5 kW to 22 kW)	<ul style="list-style-type: none">• Single phase 208-240 V \pm 10%, 1,5-4 kW, 50 or 60 Hz• Three phase 208-240 V \pm 10%, 1,5-11 kW, 50 or 60 Hz• Three phase 380-460 V \pm 10%, 1,5-22 kW, 50 or 60 Hz
Output frequency	From 30-60 Hz
EMC class	Three phase C2, single phase C1
Maximum ambient temperature	40 °C
Enclosure rating	IP55

Xylem |'zīləm|

- 1) The tissue in plants that brings water upward from the roots;
- 2) a leading global water technology company.

We're a global team unified in a common purpose: creating advanced technology solutions to the world's water challenges. Developing new technologies that will improve the way water is used, conserved, and re-used in the future is central to our work. Our products and services move, treat, analyze, monitor and return water to the environment, in public utility, industrial, residential and commercial building services settings. Xylem also provides a leading portfolio of smart metering, network technologies and advanced analytics solutions for water, electric and gas utilities. In more than 150 countries, we have strong, long-standing relationships with customers who know us for our powerful combination of leading product brands and applications expertise with a strong focus on developing comprehensive, sustainable solutions.

For more information on how Xylem can help you, go to www.xylem.com



www.xylem.com/lowara

Xylem reserves the right to make modification without prior notice.
Lowara, Xylem and hydrovar are trademarks of Xylem Inc. or one of its subsidiaries.
© 2023 Xylem, Inc. - P05/23