



# e-MP Series

HIGHLY EFFICIENT AND FLEXIBLE MULTISTAGE PUMPS UP TO 1.250kW / 1.700hp

Applications limited only by your imagination

# Benefits and technical features

## Benefits

### 1 Simple integration

Simply and cost-effectively integrate the e-MP multistage pump into nearly any high pressure application, thanks to its flexible mechanical configuration and its first stage suction impeller. This impeller provides the extremely high suction capabilities needed to meet the rigorous demands of hot water or condensate pumping applications.

### 2 Safe operation

Protect your people and reduce downtime with the e-MP pump. It incorporates a healthy assortment of built-in safeguards, such as a large self-cleaning seal chamber for contaminated liquids. Plus, you can further control and monitor safety by connecting the pump to the Xylem Hydrovar controller or other pump controller.

### 3 Energy savings

Leave a greener footprint. The high efficiency hydraulics of the e-MP multistage pump are optimized by computational fluid dynamics calculations and new U-turn channels, which create an ideal flow of pumped liquid from stage to stage. This reduces both life cycle costs and energy demand, which gives the pump MEI values well above international standards.

### 4 Projectable service

Plan and minimize maintenance downtimes with the help of optional sensor interfaces on the e-MP pump. Pressure, temperature and vibration sensors can be installed on these mechanical interfaces. By connecting them to an intelligent plant monitoring and diagnostic system, a preventative maintenance schedule for the pump can be projected in advance.

### 5 Reduced wear

Decrease your downtime, maintenance needs and operation costs thanks to an assortment of smart design features and materials that extend the life of the e-MP pump and its components. For instance, the designed plain bearing in the suction housing is made of tungsten carbide and is elastically supported to resist extreme vibrations and shocks. Cooling fins on the bearing bracket reduce the temperature and increase the life-time of the bearings. A balancing drum reduces the axial thrust of the bearings and the load on the mechanical seal. The ultimate result is a more efficient, more effective operation.

### 6 Easy maintenance

Easily service the e-MP pump, thanks to its smart, simple, modular design. The bearing at the drive side, the mechanical seal and the balancing drum bush are all easily accessible without having to remove the pump from the piping system. What's more, the pump's modularity minimizes the number of parts needed to cover the complete performance range, which simplifies assembly and streamlines spare parts management.

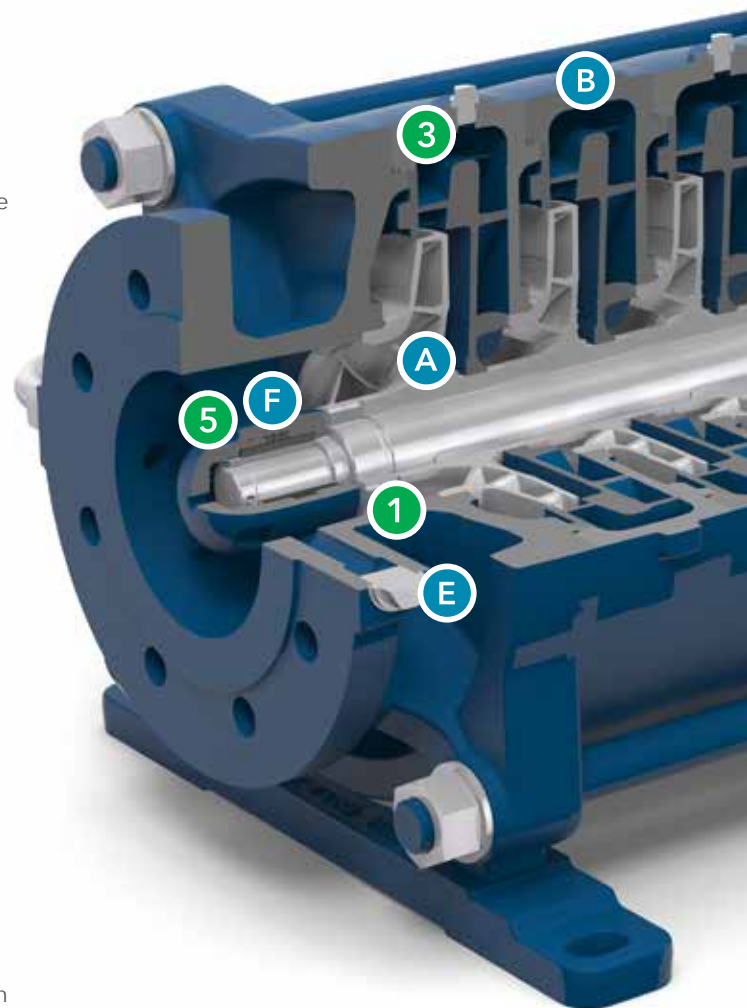

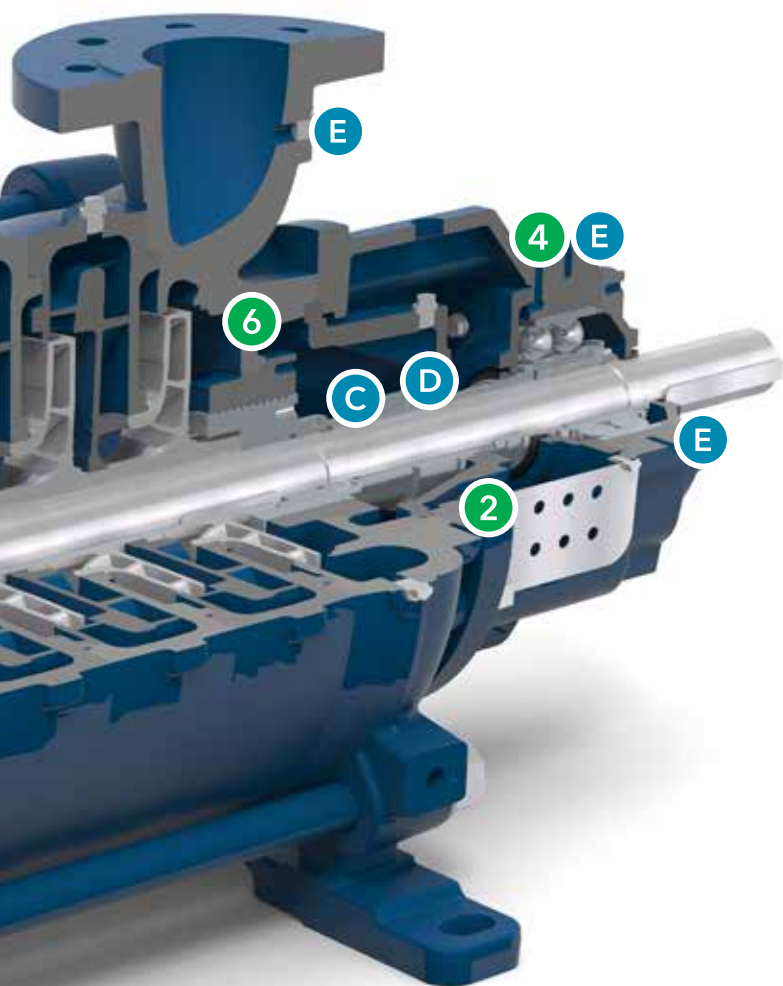

## Technical features

### A Suction impeller

Each e-MP pump is equipped in the first stage with a suction impeller. Due to the wider inlet diameter of this specially designed impeller, the velocity of the liquid is lower. This results in reduced losses and increased suction capability (or low NPSH).

### B U-turn channels

Each stage casing's salient rounded edges are called U-turn channels as the cut profile resembles a "U." This function turns pumped liquid 180° to the next stage, during which the rounded edges ensure a balanced velocity allocation of this liquid, reducing losses and increasing hydraulic efficiency.

### C Balancing system

The balancing system consists of the balancing bush, installed in the discharge casing, and its counterpart, the balancing drum, assembled on the shaft. The pumped liquid's pressure in the discharge casing pushes liquid between the bush and drum gap into the seal housing. Here, pressure acts on the drum to build force against the axial thrust of the impellers to reduce both load on the mechanical seal as well as axial thrust for the bearing, for reduced wear. The complete system can be replaced for maintenance without disassembling the pump from its piping.

### D Seal housing

A large self-cleaning seal housing equips each e-MP pump. Its cleaning process begins with its conical chamber design, transporting particles outwards along the chamber to the relief piping, then back from sealing chamber to suction side.

### E Sensor interfaces

Two pressure sensor interfaces are standard on the e-MP multistage pump, one at suction and one at discharge nozzle to measure inlet and outlet pressure. Optional sensor interfaces are available at the bearing bracket: two sensors (one for horizontal, one for vertical) to measure vibrations and one sensor that measures the bearing's temperature. The sensors can be connected to any controller to monitor the e-MP pump's performance and operation.

### F Plain bearing

The e-MP pump is equipped at the suction side with plain bearings, which are lubricated by the pumped liquid. The bearings are made of tungsten carbide and are elastically supported to resist extreme vibrations and shocks.

# Four e-MP models, designed according to ISO5199



Special features: highest suction capability (the lowest NPSH) thanks to ideal axial inlet flow, reduced wear due to fewer parts, small horizontal footprint

Special features: higher suction nozzle flexibility, reduced wear due to fewer parts, small horizontal footprint

## e-MPA

Sizes: DN50 to DN150

Configurations: horizontal

Power:  
2-pole: 7,5kW - 1.250kW / 10hp - 1.700hp  
4-pole: 2,2kW - 160kW / 3hp - 220hp

Heads up to 950m / 3.100ft

Flows up to 850m<sup>3</sup>/h / 3.740 US gpm

Temperature of pumped liquid:  
-25°C to +140°C, optional 180°C /  
-13°F to +284°F, optional 356°F

Inlet pressure up to 10 bar / 145 psi

Shaft sealing:  
Mechanical seal, cartridge seal, soft packing

Bearings:  
Suction side: plain bearing  
Discharge side: double angular ball bearing

Nozzles:  
Suction side: axial  
Discharge side: radial, 90° rotatable (left, top, right)

## e-MPR

Sizes: DN50 to DN150

Configurations: horizontal

Power:  
2-pole: 7,5kW - 1.250kW / 10hp - 1.700hp  
4-pole: 2,2kW - 160kW / 3hp - 220hp

Heads up to 950m / 3.100ft

Flows up to 850m<sup>3</sup>/h / 3.740 US gpm

Temperature of pumped liquid:  
-25°C to +140°C, optional 180°C /  
-13°F to +284°F, optional 356°F

Inlet pressure up to 10 bar / 145 psi

Shaft sealing:  
Mechanical seal, cartridge seal, soft packing

Bearings:  
Suction side: plain bearing  
Discharge side: double angular ball bearing

Nozzles:  
Suction side: 90° rotatable (left, top, right)  
Discharge side: radial, 90° rotatable (left, top, right)





Special features: higher possible inlet pressure, optional drive on the suction side



Special features: smallest footprint, four positions by nozzle (90°, 180°, 270°, 360°)

## e-MPD

Sizes: DN50 to DN150

Configurations: horizontal

Power:  
2-pole: 7,5kW - 1.250kW / 10hp - 1.700hp  
4-pole: 2,2kW - 160kW / 3hp - 220hp

Heads up to 950m / 3.100ft

Flows up to 850m<sup>3</sup>/h / 3.740 US gpm

Temperature of pumped liquid:  
-25°C to +140°C, optional 180°C /  
-13°F to +284°F, optional 356°F

Inlet pressure up to 40 bar / 580 psi

Shaft sealing:  
Mechanical seal, cartridge seal, soft packing

Bearings:  
Suction side: radial ball bearing  
Discharge side: double angular ball bearing

Nozzles:  
Suction side: 90° rotatable (left, top, right)  
Discharge side: radial, 90° rotatable (left, top, right)

## e-MPV

Sizes: DN50 to DN150

Configurations: vertical

Power:  
2-pole: 7,5kW - 355kW / 10hp - 480hp  
4-pole: 2,2kW - 160kW / 3hp - 220hp

Heads up to 630m / 2.060ft

Flows up to 850m<sup>3</sup>/h / 3.740 US gpm

Temperature of pumped liquid:  
-25°C to +140°C /  
-13°F to +284°F

Inlet pressure up to 10 bar / 145 psi

Shaft sealing:  
Mechanical seal, cartridge seal, soft packing

Bearings:  
Suction side: plain bearing  
Discharge side: double angular ball bearing

Nozzles:  
Suction side: 90° rotatable  
Discharge side: radial, 90° rotatable

# Performance range

## 50Hz

2.950 rpm (2-pole motors)

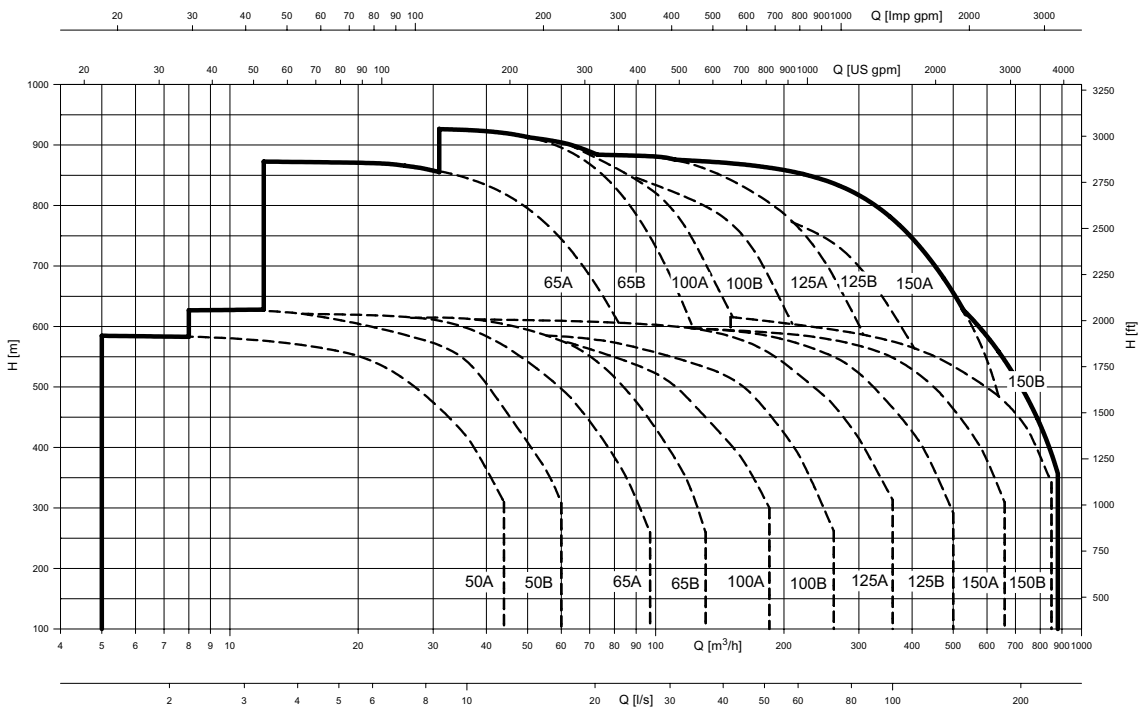

## 1.450 rpm (4-pole motors)

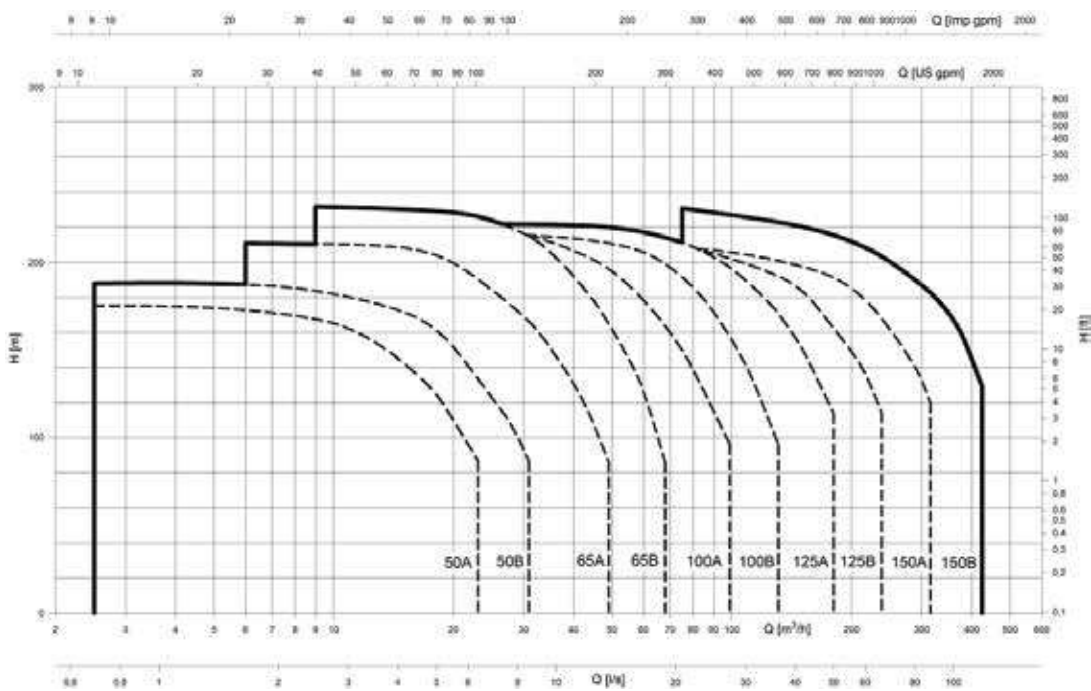

# 60Hz

3.550 rpm (2-pole motors)

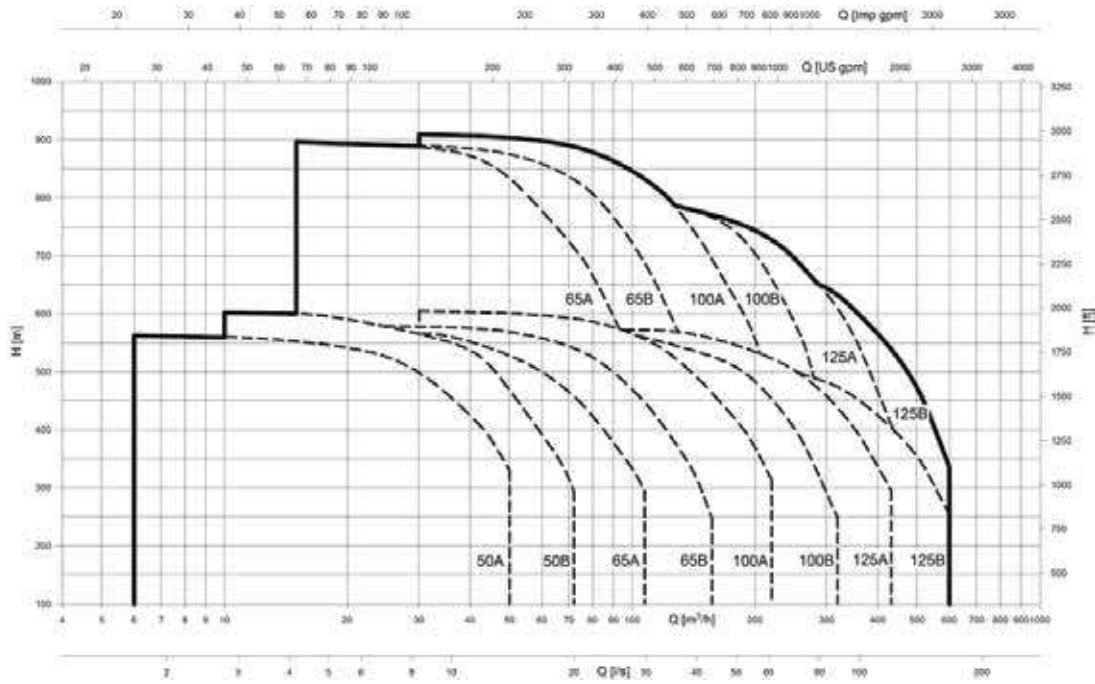

1.750 rpm (4-pole motors)

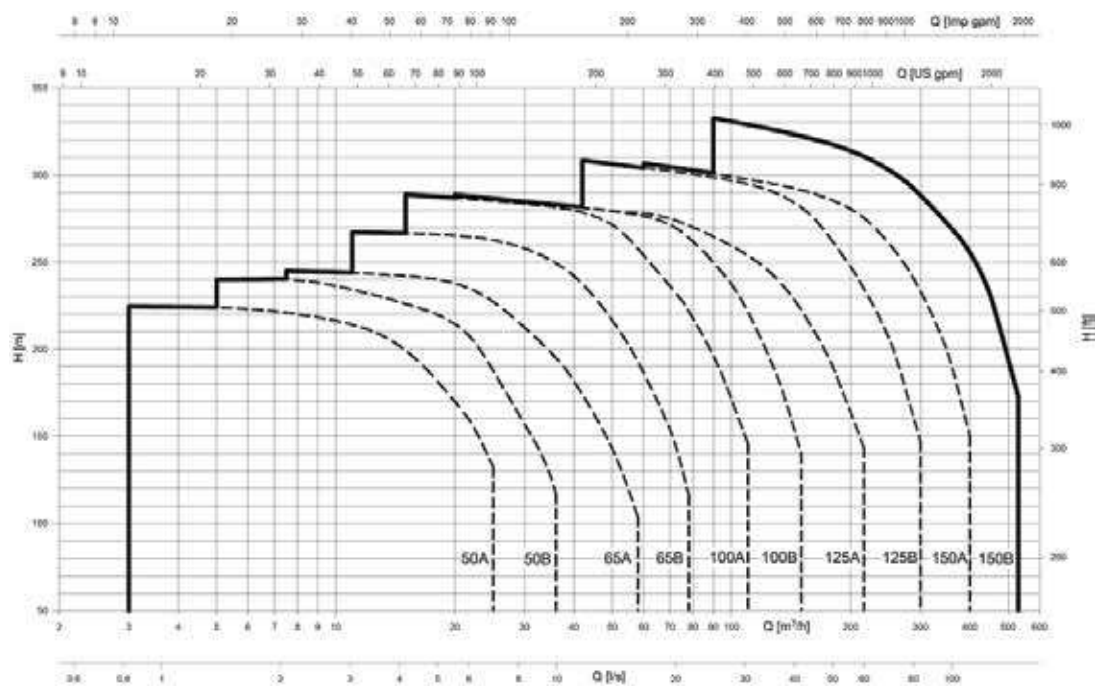

# Efficiency

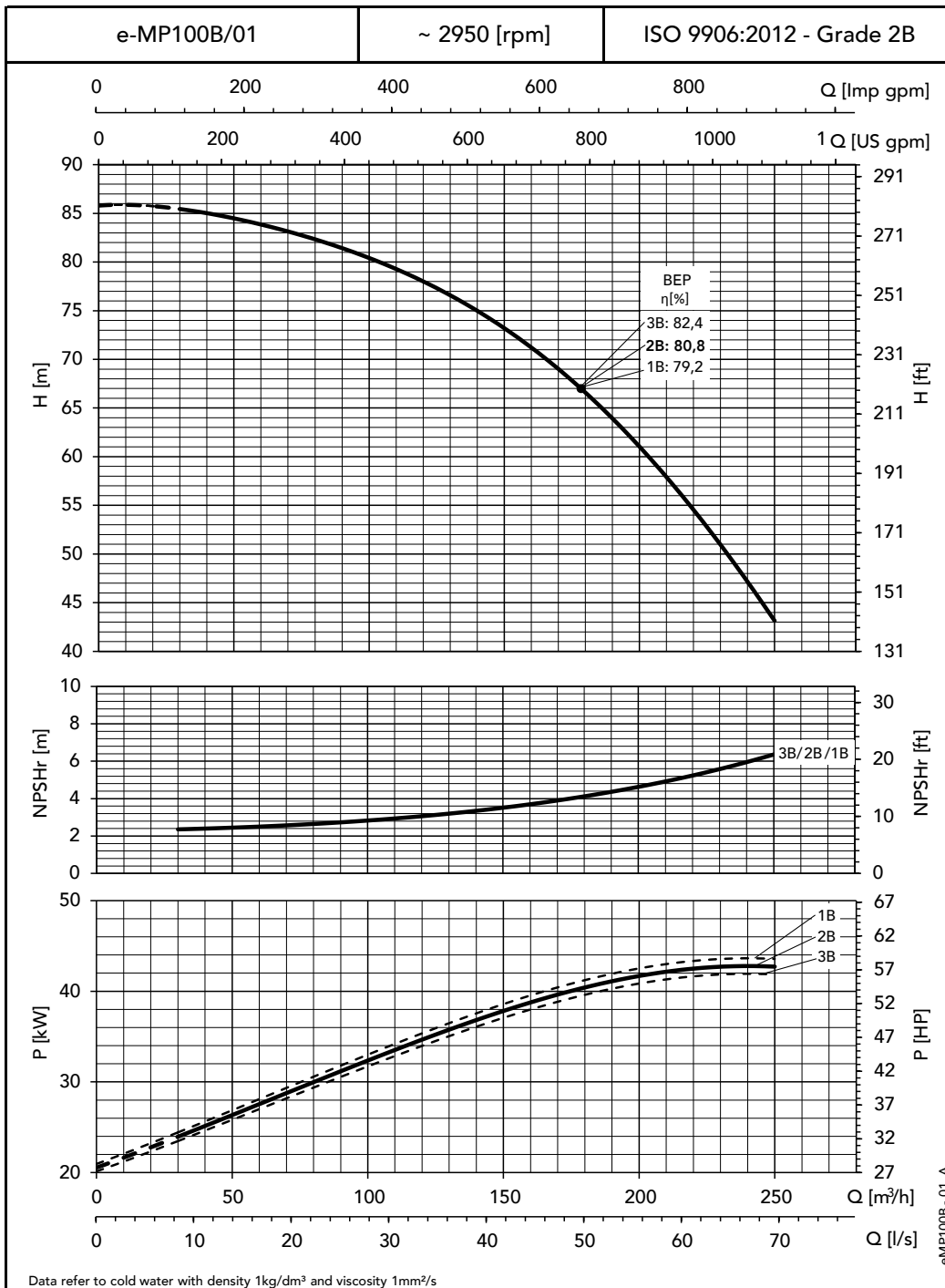

The e-MP multistage pump's performance is published according to ISO 9906:2012, acceptance test grade 2B. The ISO standard is acceptable at either the 1B, 2B or 3B test grade, but test grades cannot be compared similarly in assessing efficiency of competing products. It is critical to look beyond the percentages to determine the actual efficiency of a multistage pump.



Please see an example of our e-MP pump curves with the standard efficiency value of 80,8% ensured at 2B, as well as the optional ensured efficiency value of 79,2% at 1B. Because the efficiency value for industrial products should be declared with the appropriate degree of accuracy as recommended by ISO 9906:2012, our e-MP documentation does not represent the efficiency at test grade 3B. However, this graphic shows the hypothetical curve of efficiency if declared at 3B, which would result in a higher efficiency value of 82,4%.



# e-MP models by nominal pressure and size

		Size						
		DN50	DN65	DN100	DN125	DN150		
Nominal Pressure	100 bar (1.450 psi)						100 bar (1.450 psi)	
	63 bar (914 psi)						63 bar (914 psi)	
	40 bar (580 psi)						40 bar (580 psi)	
	25 bar (363 psi)						25 bar (363 psi)	
		DN50	DN65	DN100	DN125	DN150	Nominal Pressure	
		Size						

# Nomenclature

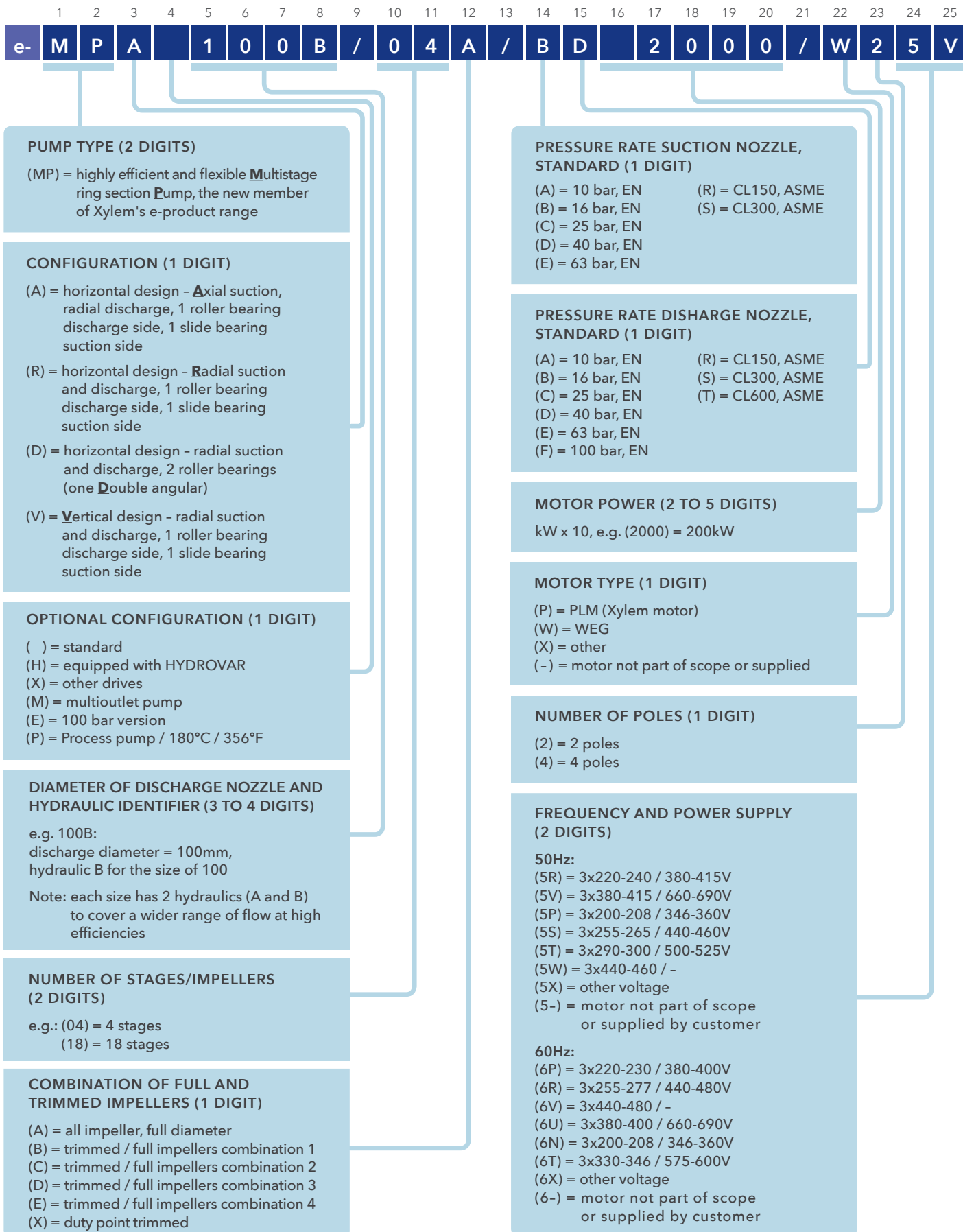

26 27 28 29 30

C C C 4

**MATERIAL PUMPHOUSING: SUCTION, DISCHARGE AND STAGE CASING (1 DIGIT)**

- (C) = cast iron
- (D) = ductile iron
- (F) = cast steel
- (N) = stainless steel
- (R) = duplex
- (T) = super duplex
- (X) = other

**MATERIAL IMPELLER (1 DIGIT)**

- (C) = cast iron
- (B) = bronze
- (N) = stainless steel
- (R) = duplex
- (T) = super duplex
- (X) = other

**MATERIAL DIFFUSER (1 DIGIT)**

- (C) = cast iron
- (N) = stainless steel
- (R) = duplex
- (T) = super duplex
- (X) = other

**MATERIALS MECHANICAL SEAL AND O-RING (1 DIGIT)**

- (4) = carbon / SiC / EPDM
- (2) = carbon / SiC / FPM
- (Z) = SiC / SiC / EPDM
- (W) = SiC / SiC / FPM
- (N) = tungsten carbide / SiC / FPM
- (X) = other
- (-) = soft packing

**TYPE OF SEAL (1 DIGIT)**

- ( ) = mechanical seal, standard
- (C) = cartridge seal
- (P) = soft packing

## Examples

Pump mounted on frame, coupled with motor, MPA100B/04A/BD2000/W25VCCCC4:

Series e-MP, horizontal configuration, axial suction inlet, radial discharge nozzle, size DN100, hydraulic B, 4 stages/impellers, all impellers with full diameter, 16 bar suction nozzle, 40 bar discharge nozzle, coupled with a 200kW motor from WEG with 2 poles for 50Hz 3x380-415/660-690V supply, frame mounted, suction and discharge casing material made of cast iron, impellers and diffusers made of cast iron, mechanical seal carbon/SiC, O-rings made of EPDM

Pump mounted on frame, with coupling, motor not part of scope or supplied by customer, MPA100B/04A/BD2000/-25-CCC4:

Series e-MP, horizontal configuration, axial suction inlet, radial discharge nozzle, size DN100, hydraulic B, 4 stages/impellers, all impellers with full diameter, 16 bar suction nozzle, 40 bar discharge nozzle, frame mounted, coupling and coupling guard included, prepared to assemble a 200kW, 2-pole motor, 50Hz, suction and discharge casing material made of cast iron, impellers and diffusers made of cast iron, mechanical seal carbon/SiC, O-rings made of EPDM

Bareshaft pump, MPA100B/04A/BD/-25-CCC4:

Series e-MP, horizontal configuration, axial suction inlet, radial discharge nozzle, size DN100, hydraulic B, 4 stages/impellers, all impellers with full diameter, 16 bar suction nozzle, 40 bar discharge nozzle, 2-pole motor, 50Hz, suction and discharge casing material made of cast iron, impellers and diffusers made of cast iron, mechanical seal carbon/SiC, O-rings made of EPDM

**Note:**

- 1) "e-" in front of MP is used for all marketing materials and in the selection tools
- 2) "e-" in front of MP is NOT used on the name plate and NOT in denomination of pumps
- 3) Unused nomenclature digits - e.g. if the digit description is ( ) - are skipped and the next used digit is shifted to the left
- 4) If the digit description is (-), the "-" is used in the nomenclature (refer to examples)

# Standard pump material configurations

	CCC	CBC	CNC	NNN
Nominal operating pressure	up to 40 bar / 580 psi			
Suction impeller (1st stage)	Cast iron (EN-GJL-200)	Bronze (CuSn10-C)	Stainless steel (1.4408)	Stainless steel (1.4408)
Impeller	Cast iron (EN-GJL-200)	Bronze (CuSn10-C)	Stainless steel (1.4408)	Stainless steel (1.4408)
Diffuser	Cast iron (EN-GJL-150)	Cast iron (EN-GJL-150)	Cast iron (EN-GJL-150)	Stainless steel (1.4408)
Stage casing	Cast iron (EN-GJL-250)	Cast iron (EN-GJL-250)	Cast iron (EN-GJL-250)	Stainless steel (1.4408)
Suction casing	Cast iron (EN-GJL-250)	Cast iron (EN-GJL-250)	Cast iron (EN-GJL-250)	Stainless steel (1.4408)
Discharge casing	Cast iron (EN-GJL-250)	Cast iron (EN-GJL-250)	Cast iron (EN-GJL-250)	Stainless steel (1.4408)
Seal cover	Cast iron (EN-GJL-250)	Cast iron (EN-GJL-250)	Cast iron (EN-GJL-250)	Stainless steel (1.4408)
Bearing bracket / motor adapter	Cast iron (EN-GJL-250)			
Pump foot (horizontal / vertical)	Cast iron (EN-GJL-250)*			
Wear ring	Optional, duplex (1.4462)	Optional, duplex (1.4462)	Optional, duplex (1.4462)	Duplex (1.4462)
Drum	Stainless steel (1.4057)			
Drum bush	Cast iron (EN-GJL-250)	Cast iron (EN-GJL-250)	Cast iron (EN-GJL-250)	Duplex (1.4462)
Shaft	Stainless steel (1.4057)	Stainless steel (1.4057)	Stainless steel (1.4057)	Duplex (1.4462)
Shaft sleeve	Stainless steel (1.4057)	Stainless steel (1.4057)	Stainless steel (1.4057)	Duplex (1.4462)
Relief pipe	Stainless steel (1.4571)			

	DCC	DBC	DNC
Nominal operating pressure	up to 63 bar / 914 psi		
Suction impeller (1st stage)	Cast iron (EN-GJL-200)	Bronze (CuSn10-C)	Stainless steel (1.4408)
Impeller	Cast iron (EN-GJL-200)	Bronze (CuSn10-C)	Stainless steel (1.4408)
Diffuser	Cast iron (EN-GJL-150)		
Stage casing	Ductile iron (EN-GJS-400-15)		
Suction casing	Ductile iron (EN-GJS-400-15)		
Discharge casing	Ductile iron (EN-GJS-400-15)		
Seal cover	Ductile iron (EN-GJS-400-15)		
Bearing bracket / motor adapter	Cast iron (EN-GJL-250)		
Pump foot (horizontal / vertical)	Cast iron (EN-GJL-250)*		
Wear ring	Optional, duplex (1.4462)		
Drum	Stainless steel (1.4057)		
Drum bush	Cast iron (EN-GJL-250)		
Shaft	Stainless steel (1.4057)		
Shaft sleeve	Stainless steel (1.4057)		
Relief pipe	Stainless steel (1.4571)		

	DCC	DNC	RNN	RRR	TTT
Nominal operating pressure	up to 100 bar / 1.450 psi				
Suction impeller (1st stage)	Cast iron (EN-GJL-200)	Stainless steel (1.4408)	Stainless steel (1.4408)	Duplex (1.4517)	Super duplex (1.4469)
Impeller	Cast iron (EN-GJL-200)	Stainless steel (1.4408)	Stainless steel (1.4408)	Duplex (1.4517)	Super duplex (1.4469)
Diffuser	Cast iron (EN-GJL-150)	Cast iron (EN-GJL-150)	Stainless steel (1.4408)	Duplex (1.4517)	Super duplex (1.4469)
Stage casing	Ductile iron (EN-GJS-400-15)	Ductile iron (EN-GJS-400-15)	Duplex (1.4517)	Duplex (1.4517)	Super duplex (1.4469)
Suction casing	Ductile iron (EN-GJS-400-15)	Ductile iron (EN-GJS-400-15)	Duplex (1.4517)	Duplex (1.4517)	Super duplex (1.4469)
Discharge casing	Cast steel (1.0619)	Cast steel (1.0619)	Duplex (1.4517)	Duplex (1.4517)	Super duplex (1.4469)
Seal cover	Duplex (1.4517)	Duplex (1.4517)	Duplex (1.4517)	Duplex (1.4517)	Super duplex (1.4469)
Bearing bracket / motor adapter	Cast iron (EN-GJL-250)				
Pump foot (horizontal / vertical)	Cast iron (EN-GJL-250)*				
Wear ring	Optional, duplex (1.4462)	Optional, duplex (1.4462)	Duplex (1.4462)	Duplex (1.4462)	Super duplex (1.4410)
Drum	Stainless steel (1.4057)	Stainless steel (1.4057)	Stainless steel (1.4057)	Duplex (1.4462)	Super duplex (1.4410)
Drum bush	Cast iron (EN-GJL-250)	Cast iron (EN-GJL-250)	Duplex (1.4462)	Duplex (1.4462)	Super duplex (1.4469)
Shaft	Stainless steel (1.4057)	Stainless steel (1.4057)	Duplex (1.4462)	Duplex (1.4462)	Super duplex (1.4410)
Shaft sleeve	Stainless steel (1.4057)	Stainless steel (1.4057)	Duplex (1.4462)	Duplex (1.4462)	Super duplex (1.4410)
Relief pipe	Stainless steel (1.4571)	Stainless steel (1.4571)	Stainless steel (1.4571)	Austenitic steel (1.4539)	Austenitic steel (1.4539)

MATERIAL		REFERENCE STANDARDS	
		EUROPE	USA**
Cast iron	(EN-GJL-150)	EN 1561 - JL1020	ASTM - CLASS 25
Cast iron	(EN-GJL-200)	EN 1561 - JL1030	ASTM - CLASS 30
Cast iron	(EN-GJL-250)	EN 1561 - JL1040	ASTM - CLASS 35
Ductile iron	(EN-GJS-400-15)	EN 1563 - JS1030	ASTM - 65-45-12
Bronze	(CuSn10-C)	EN 1982 - CC480K	ASTM - C90700
Cast steel	(1.0619)	EN 10213 - GP240GH	ASTM - WCB
Stainless steel	(1.4408)	EN 10283 - GX 5 CrNiMo 19 11 2	ASTM - CF8M
Duplex	(1.4517)	EN 10283 - GX 2 CrNiMoCuN 25 6 3 3	ASTM - CD4MCuN
Super duplex	(1.4469)	EN 10283 - GX 2 CrNiMoN 26 7 4	ASTM - CE3MN
Carbon steel	(1.0038)	EN 10025 - S235JR	ASTM - Grade C, D
Stainless steel	(1.4057)	EN 10088 - X 17CrNi 16 2	ASTM - 431
Stainless steel	(1.4571)	EN 10088 - X 6 CrNiMoTi 17 12 2	ASTM - 316Ti
Austenitic steel	(1.4539)	EN 10088 - X 1 NiCrMoCu 25 20 5	ASTM - 904L
Duplex	(1.4462)	EN 10088 - X 2 CrNiMoN 22 5 3	ASTM - F51
Super duplex	(1.4410)	EN 10088 - X 2 CrNiMoN 25 7 4	ASTM - F53

\*Carbon steel (1.0038) for size 125 and 150 in horizontal configuration. \*\*Similar grades according to U.S. standards.



# Standard scope of supply and accessories

## Standard scope of supply

(See nomenclature on page 12 for name sequence)

<p><b>Pump mounted on frame, coupled with motor</b> MPA100B/04A/BD2000/W25VCCC4</p>	
<p><b>Pump mounted on frame, with coupling, motor not part of scope or supplied by customer</b> MPA100B/04A/BD2000/-25-CCC4</p>	
<p><b>Bareshaft pump</b> MPA100B/04A/BD/-25-CCC4</p>	

## Accessories

- Frames
- Couplings and coupling guards
- Motors:
  - 2-pole: 7,5kW to 1.250kW / 10hp to 1.700hp
  - 4-pole: 2,2kW to 160kW / 3hp to 220hp
- Monitoring and control interfaces
- Temperature and vibration sensor interfaces (pressure sensor interface is standard)
- Hydrovar HVL and Hydrovar Smart (see next page for further information)

Do you have requirements outside of the standard and optional range? Consult our Xylem sales force to discuss special engineered-to-order solutions, e.g. fly wheels to avoid water shocks in piping.

# Make your system even more efficient

## HYDROVAR HVL and HYDROVAR SMART

Energy is the greatest cost of running any pump. Fifth generation Hydrovar Variable Speed Drives work with your ultra-efficient e-MP system to make it even more efficient. It can further reduce your energy use by up to 70%, depending on your costs and operating times. At that rate, the Hydrovar typically pays for itself within two years.

**HYDROVAR HVL:** 1,5kW to 22kW, can be mounted to motor or wall

**HYDROVAR SMART:** Over 22kW, combines all Hydrovar intelligence with any frequency drive, and can be installed anywhere due to its slim design (e.g. inside of the control panel)



Features	HYDROVAR HVL	HYDROVAR SMART
Fits onto any standard asynchronous motor	●	
Advanced motor control	●	●
THDi filter embedded	●	on request
Extended communication capabilities	●	●
Easy to commission and operate	●	●
Multi-pump capability	up to 8	up to 4

## Select the right pump for your variable speed system

When selecting a pump for a variable speed controlled system, the whole working range of the pump must be taken into consideration. Since a pump mostly works in partial load, the best efficiency point should not be at the maximum duty point.

The selected pump should have a maximum duty point to the right of the best efficiency point, within an acceptable range (e.g. opt -10%).

This selection guarantees that, in partial load, the pump works at high efficiency within a wide range. When it is possible that load conditions will be low for long periods, the system should be split into two pumps, or a jockey pump should be installed.

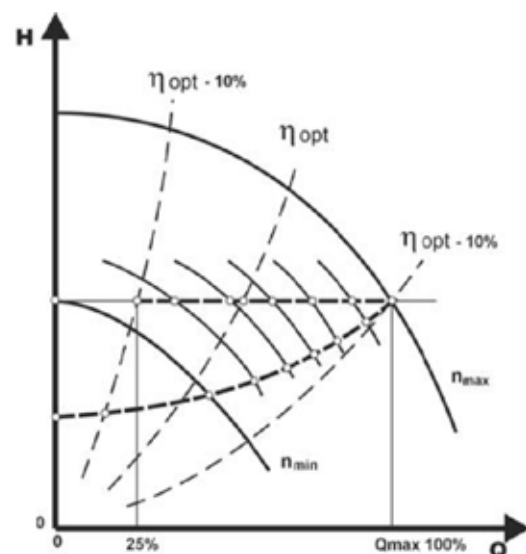

# Markets and applications



## General industry

All manufacturing industries, including steel, sugar, timber, tire and rubber, pulp and paper, car, food and beverage

**Applications:** cooling and heating circuits for industrial processes, sprinkler systems, washing and cleaning systems, firefighting systems, filter systems, water transport systems, booster systems, water treatment systems



## Power plants

Renewable energy, hydropower, biomass, geothermal, fossil power

**Applications:** boiler feed, condensate pumping, de-aerating, water injection, water transport, auxiliary systems, firefighting systems, cooling and heating circuits, district cooling and heating systems



## Oil and gas

On-shore platforms, off-shore platforms, refineries, fracking

**Applications:** transport of crude oil, sea water/water injection, firefighting systems, water transport, water treatment



## Mining

**Applications:** dewatering filtered water, water transport, firefighting systems



## Commercial building services

**Applications:** water transport, booster systems, firefighting systems, HVAC systems



## Agriculture

**Applications:** water transport, irrigation



## Public utilities

Water works, desalination plants, drainage and flood protection, tunnels

**Applications:** district cooling and heating systems, water transport, water treatment systems, desalinization, reverse osmosis, nanofiltration, firefighting systems, booster systems



## Leisure industry

Ski resorts, leisure parks, spas

**Applications:** snow making, water transport, water boosting



## Others

**Applications:** e.g. auxiliary applications in chemical industry, all water boosting applications

Xylem's multistage pump ranges have been satisfying the needs of customers for over a century. Today, they operate successfully across the world in a variety of markets and applications.

## Pumpable fluids:

- Water
- Gray/used water
- Groundwater
- Potable water
- Thermal water
- Seawater in all regions
- Brackish water
- Feed water
- Hot water
- Condensate
- Cooling/heating water
- Solvents
- Lubricants
- Crude oil
- Oil emulsions
- Fuels



# Product timeline



## 1910: the story begins

The story began with the invention of the diffuser. It dramatically increased the efficiency of multistage pumps by optimizing flow from one stage to the next.

## Multistage pump models for medium pressure

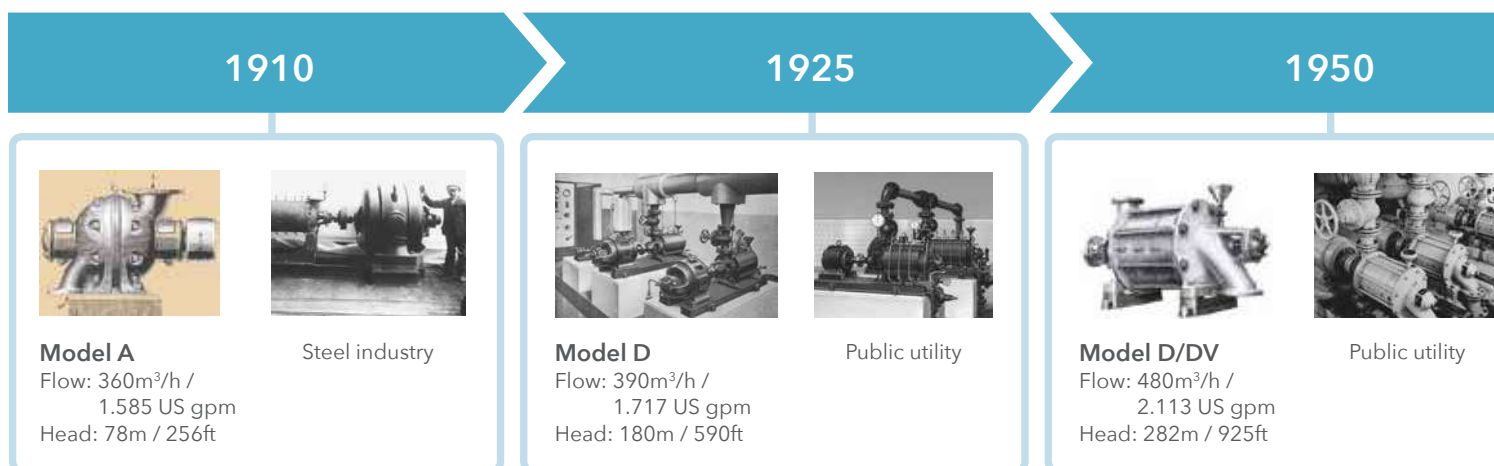

## Multistage pump models for high pressure







## 2017: the story continues

The story is continued with the e-MP. It is the next generation of highly efficient and flexible multistage pumps.

1970



### Model P

Flow: 1.800m<sup>3</sup>/h /  
7.925 US gpm  
Head: 300m / 984ft

District heating

1998



### Model MP

Flow: 340m<sup>3</sup>/h /  
1.497 US gpm  
Head: 500m / 1.640ft

Mine dewatering

2017

2000



### Model MPE

Flow: 300m<sup>3</sup>/h /  
1.320 US gpm  
Head: 800m / 2.625ft

Snow making

2017



### Model e-MP

Flow: 850m<sup>3</sup>/h /  
3.740 US gpm  
Head: 950m / 3.100ft

# Xylem |'zīləm|

- 1) The tissue in plants that brings water upward from the roots;
- 2) a leading global water technology company.

We're a global team unified in a common purpose: creating advanced technology solutions to the world's water challenges. Developing new technologies that will improve the way water is used, conserved, and re-used in the future is central to our work. Our products and services move, treat, analyze, monitor and return water to the environment, in public utility, industrial, residential and commercial building services, and agricultural settings. With its October 2016 acquisition of Sensus, Xylem added smart metering, network technologies and advanced data analytics for water, gas and electric utilities to its portfolio of solutions. In more than 150 countries, we have strong, long-standing relationships with customers who know us for our powerful combination of leading product brands and applications expertise with a strong focus on developing comprehensive, sustainable solutions.

**For more information on how Xylem can help you, go to [www.xylem.com](http://www.xylem.com)**



For information and  
technical support:

**Xylem Service Italia Srl**

Via Dottor Vittorio Lombardi 14

36075 - Montecchio Maggiore (VI)

Italy

Tel. (+39) 0444 707111

Fax (+39) 0444 491043

We reserve the right to make modification without prior notice.  
Xylem is a trademark of Xylem Inc. or one of its subsidiaries. Goulds  
is a registered trademark of Goulds Pumps, Inc. and is used under  
license. © 2018 Xylem, Inc.