

**MOTOR SPEED PRODUCT LINE:
STEEL EXTERNALS — MAG DRIVE PUMPS
SERIES 893**

Section	1343
Page	1343.1
Issue	C

TABLE OF CONTENTS

Features & Benefits 2
 Standard Materials of Construction 2
 Model Number Key 3
 Cutaway View & Pump Features 3
 Specifications 4
 Dimensions – GG, HJ, HL Sizes (*Unmounted*) 4
 Dimensions – GG Sizes – MD-A4 & MD-A9 (*B Drive*) 5
 Dimensions – HJ, HL Sizes – MD-A4 & MD-A9 (*B Drive*) 5
 Dimensions – HJ, HL Sizes – MD-B15 & MD-B40 (*M Drive*) 6
 Dimensions – AS, AK, AL Sizes (*Unmounted*) 6
 Dimensions – AS, AK, AL Sizes – MD-B15 & B40 (*B Drive*) 7
 Dimensions – AS, AK, AL Sizes – MD-C80 (*B Drive*) 8
 Dimensions – AS, AK Sizes – MD-B15 & B40 (*M Drive*) 9
 Dimensions – AL Sizes – MD-B15 & B40 (*M Drive*) 9
 NPSH Required 10
 Selecting the Correct Viking Mag Drive® Coupling 11
 Example 1 11
 Example 2 11

RELATED PRODUCTS

Steel Externals, 493/4193 Series: Catalog Section 1341
 Cast Iron, 895 Series Mag Drive: Catalog Section 1443
 Stainless Steel, 897 Series Mag Drive: Catalog Section 1743

SERIES DESCRIPTION

893 Series pumps are designed to provide positive displacement pumping capability in those situations that require the highest assurance of liquid containment. These mag drive pumps provide for the safe, trouble-free transfer of hazardous, EPA-regulated fluids without electronic monitoring as required with mechanical face-type shaft seals. Hard-to-seal liquids are also easily handled with the Viking Mag Drive which eliminates the high cost of mechanical seal replacement and repair. A variety of coupling sizes are available for flow requirements to 75 GPM. The torque-carrying ability of high-strength magnets allows pumps to be coupled with gear reducers for slow-speed handling of viscous liquids. The self-priming positive-displacement pumping principle provides low-shear, non-pulsing flow. Internal gear pumps are available in stainless steel, steel, and cast iron construction.

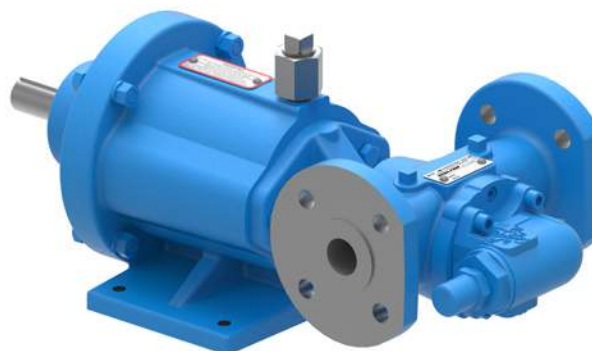

**GG893
MD-B40B, bearing carrier, footed bracket,
and mounted pump with flanged ports
(shown with optional temperature probe connection)**

OPERATING RANGE

SERIES	NOMINAL FLOW		MAXIMUM PRESSURE		TEMPERATURE RANGE		VISCOSITY RANGE	
	GPM	m ³ h	PSI	Bar	°F	°C	SSU	cSt
893	7 - 75	1.6 - 17	125	8.5	-60 to +500	-50 to +260	28 to 250,000	1 to 55,000

Section	1343
Page	1343.2
Issue	C

MOTOR SPEED PRODUCT LINE: STEEL EXTERNALS — MAG DRIVE PUMPS SERIES 893

FEATURES & BENEFITS

- Internal Gear
 - » With only two moving parts, Viking Mag Drive and Viking's gear-within-a-gear principle provides low-shear pumping.
- Magnetic Coupling
 - » Viking Mag Drive magnetically couples the pump to the driver. Magnetic force passing through a stainless steel canister is used to drive the inner coupling, eliminating the need for shaft seals.

STANDARD MATERIALS OF CONSTRUCTION

Component		Standard Material
Casing		Steel, ASTM A216, Grade WCB
Head		Steel, ASTM A216, Grade WCB
Idler	Standard	② PPS Composite
	Optional	Cast Iron, ASTM A48, Class 35B (GG, HL)
Rotor	Standard	Cast Iron, ASTM A48, Class 35B (GG, HL) Ductile Iron, ASTM A536 Grade 60-40-18 (HL, AS, AK, AL)
	Optional	① Steel, ASTM A148, Grade 80-50
Rotor Shaft		Hardened Steel ASTM A108, Grade 1045
Idler Pin		Hardened Steel ASTM A108, Grade 1045
Idler & Casing Bushing	Standard	Carbon Graphite
	Optional	Hardened Cast Iron, Silicon Carbide
Internal Pressure Relief Valve		③ Steel, ASTM A216, Grade WCB
Canister		③ 316L Stainless Steel
Coupling Magnets	Standard	Neodymium Iron Boron
	Optional	Samarium Cobalt
O-rings	Standard	FKM
	Optional	PTFE (Derivative) Encapsulated, FFKM

① Hardened steel rotor will be provided on GG & HJ sizes. GG uses steel idler when steel fitted pump is required.

② Standard Material is Polyphenylene Sulfide composite material. Recommend using metal idler above 10,000 SSU.

③ MD-A canisters are 316 stainless steel.

**MOTOR SPEED PRODUCT LINE:
STEEL EXTERNALS — MAG DRIVE PUMPS
SERIES 893**

Section	1343
Page	1343.3
Issue	C

MODEL NUMBER KEY

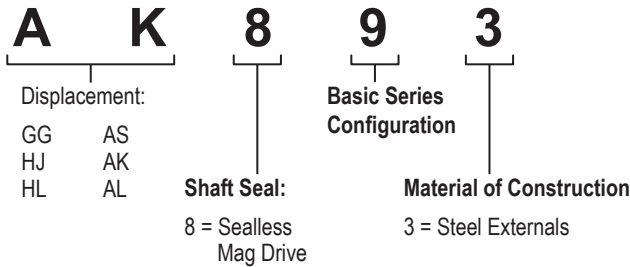

CUTAWAY VIEW & PUMP FEATURES

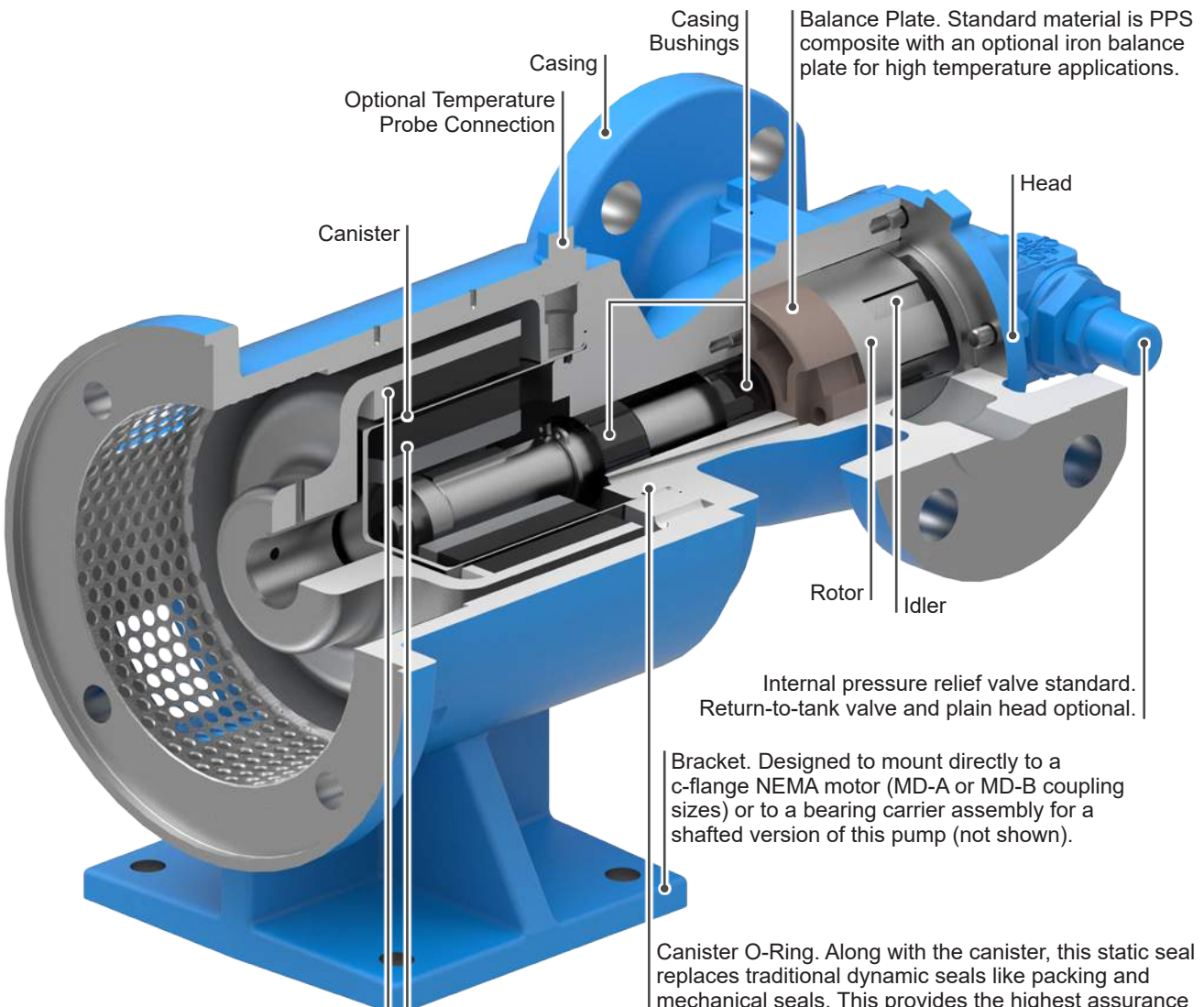

Internal pressure relief valve standard.
Return-to-tank valve and plain head optional.

Bracket. Designed to mount directly to a c-flange NEMA motor (MD-A or MD-B coupling sizes) or to a bearing carrier assembly for a shafted version of this pump (not shown).

Canister O-Ring. Along with the canister, this static seal replaces traditional dynamic seals like packing and mechanical seals. This provides the highest assurance against leakage on difficult to seal liquids.

The outer magnet is the drive magnet, driven directly by the motor.

Inner Magnet Assembly. The inner magnet is the driven magnet, aligned by magnetic force passing through the canister. The inner magnet assembly is shielded in a laser welded 316SS housing to prevent exposure of the magnets to the liquid.

Section	1343
Page	1343.4
Issue	C

MOTOR SPEED PRODUCT LINE: STEEL EXTERNALS — MAG DRIVE PUMPS SERIES 893

SPECIFICATIONS

Model Number	Port Size Inches	Nominal Pump Rating (100 SSU & below)			① Magnetic Coupling Availability			② Maximum Temperature		④ Maximum Hydrostatic Pressure		Approximate Pump Shipping Weight with Valve (less power)		③ Approximate Coupling Only Shipping Weight (ready to accept but less power)	
					Series	Torque		°F	°C	PSIG	BAR	Lbs.	Kg.	Lbs.	Kg.
						Ft-Lbs	Nm								
GG893	1	10 7	2.3 1.6	1800 1200	MD-A	4 9	5.4 12.2	225	93	400	28	22	10	31	14
					MD-B	40	54								
HJ893	1½	20 13	4.5 3	1800 1200	MD-A	4 9	5.4 12.2	225	93	400	28	30	14	31	14
					MD-B	40	54								
HL893	1½	30 20	6.8 4.5	1800 1200	MD-A	4 9	5.4 12.2	225	93	400	28	30	14	31	14
					MD-B	40	54								
AS893	3	35	8	1200	MD-B	40	54	225	93	400	28	78	35	71	32
					MD-C	80	108	225	93	400	28	78	35	95	43
AK893	3	50	11	1200	MD-B	40	54	225	93	400	28	78	35	71	32
					MD-C	80	108	225	93	400	28	78	35	95	43
AL893	3	75	17	1200	MD-B	40	54	225	93	400	28	78	35	71	32
					MD-C	80	108	225	93	400	28	78	35	95	43

① See Performance Curves, which can be electronically generated with the Viking Pump Curve Generator, located on www.vikingpump.com, for specific coupling recommendation on other pressures and viscosities. See page 11 for "Selecting the correct Mag Drive coupling."

② Higher temperatures can be handled with Samarium Cobalt magnets. See page 11 for torque and temperature limits.

③ For bearing carrier weights add 8 Lbs (2 Kg) for "MD-A" size, add 17 Lbs (4 Kg) for "MD-B" size.

④ Hydrostatic pressure limit is a function of ports, head gaskets, and canister ratings. Higher pressures available with special construction.

DIMENSIONS – GG, HJ, HL SIZES (UNMOUNTED)

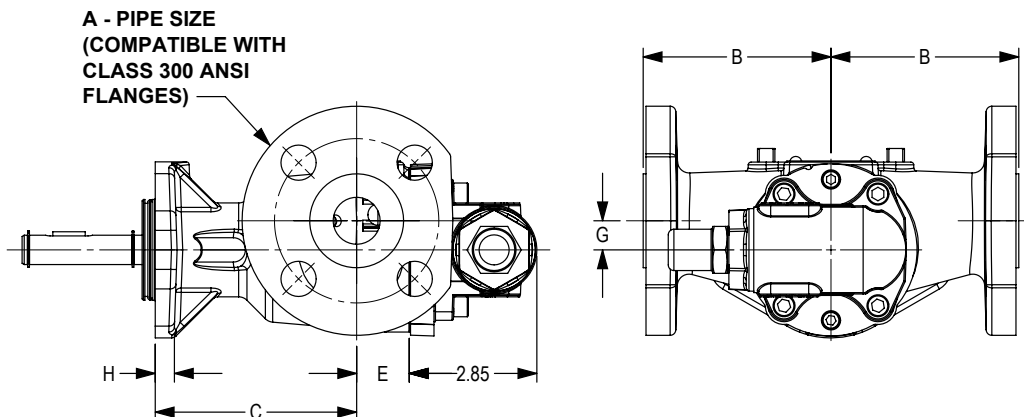

Model Number	A (in)		B	C	E	G	H
GG-893	1	in	4.00	4.29	1.12	0.62	0.50
		mm	102	108	29	16	13
HJ-893 HL-893	1½	in	4.00	5.44	1.50	0.62	0.50
		mm	102	138	38	16	13

These dimensions are average and not for construction purposes. Certified prints on request.

**MOTOR SPEED PRODUCT LINE:
STEEL EXTERNALS — MAG DRIVE PUMPS**

SERIES 893

Section	1343
Page	1343.5
Issue	C

DIMENSIONS – GG SIZES – MD-A4 & MD-A9 (B DRIVE)

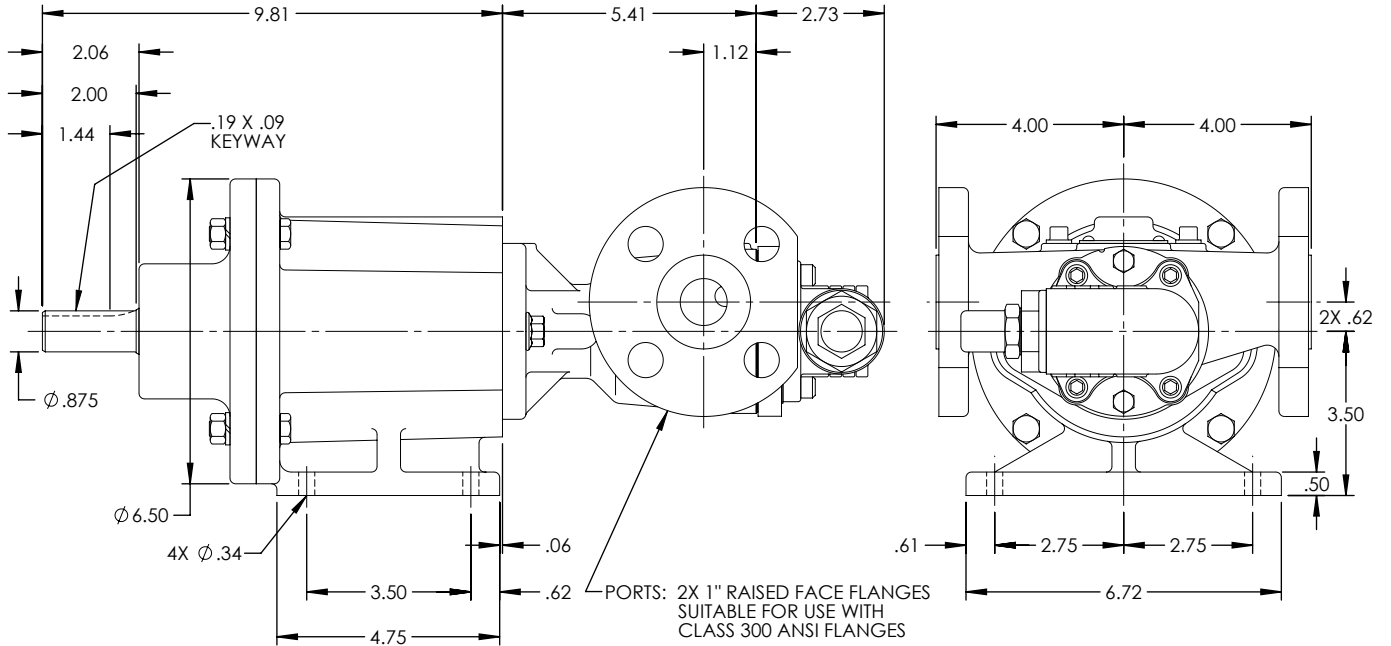

DIMENSIONS – HJ, HL SIZES – MD-A4 & MD-A9 (B DRIVE)

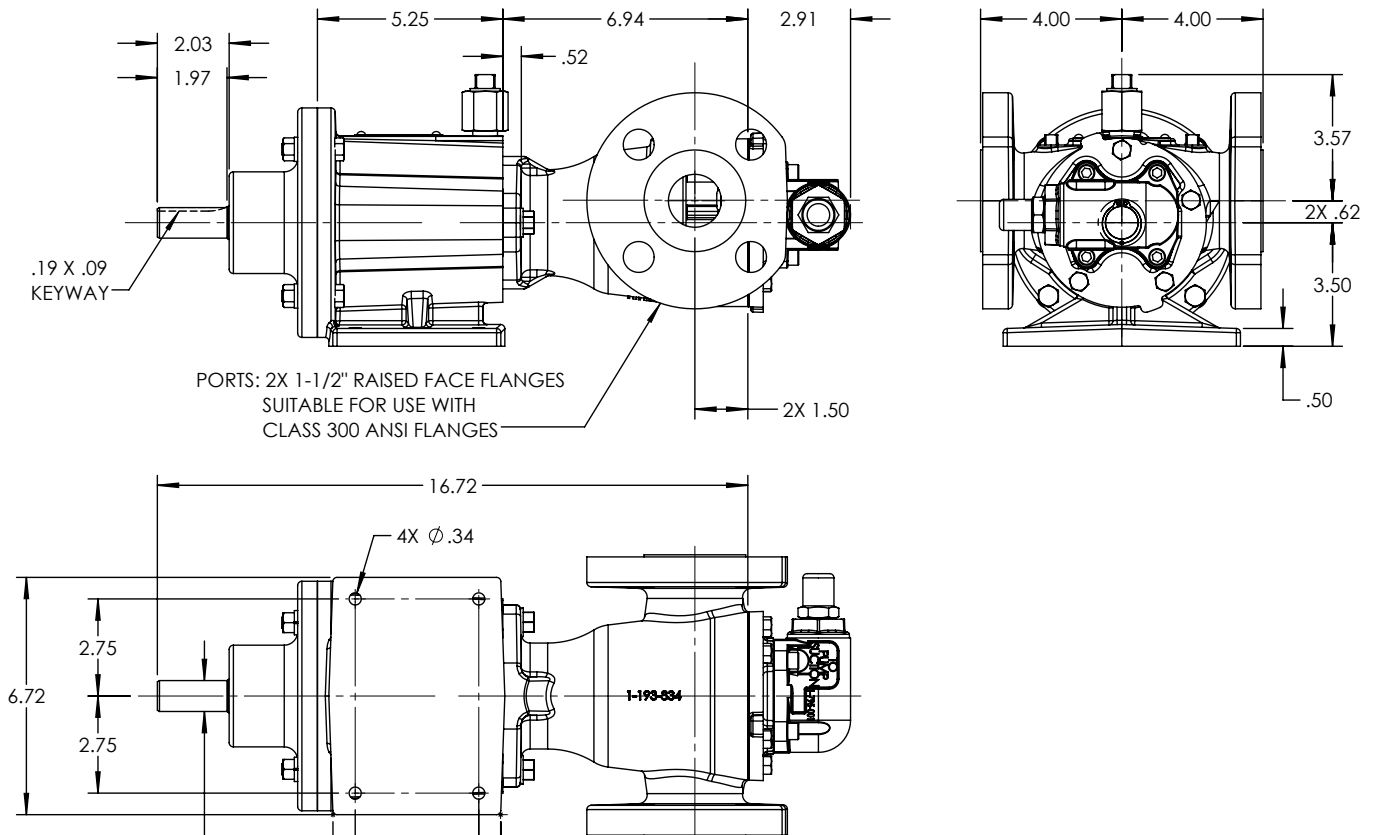

These dimensions are average and not for construction purposes. Certified prints on request.

Section	1343
Page	1343.6
Issue	C

**MOTOR SPEED PRODUCT LINE:
STEEL EXTERNALS — MAG DRIVE PUMPS
SERIES 893**

DIMENSIONS – HJ, HL SIZES – MD-B15 & MD-B40 (M DRIVE)

MOTOR: FRAMES
182TC-184TC
213TC-215TC

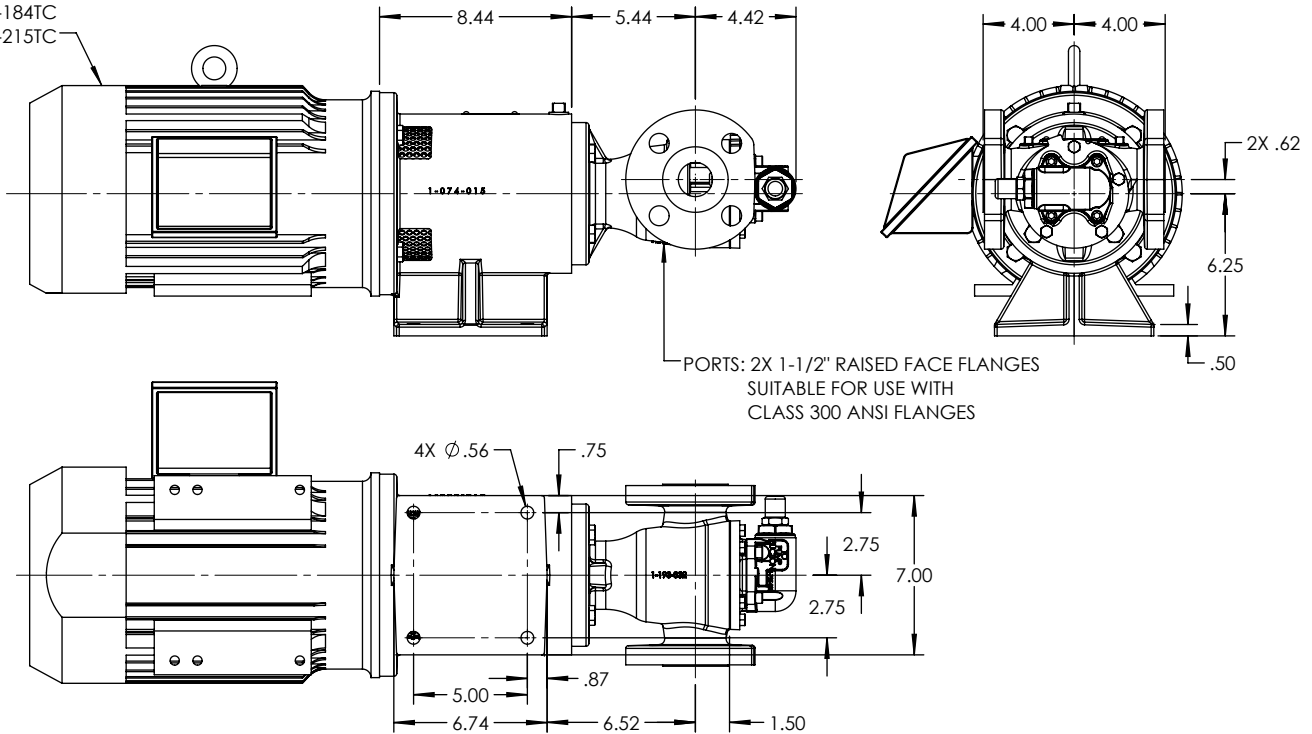

DIMENSIONS – AS, AK, AL SIZES (UNMOUNTED)

A - PIPE SIZE
(COMPATIBLE WITH
CLASS 300 ANSI FLANGES)

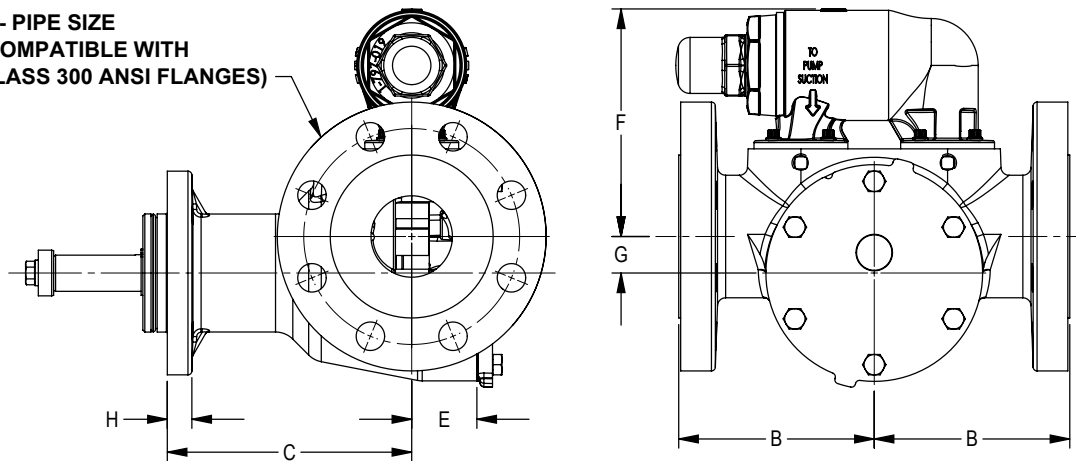

Model Number	A (in)		B	C	E	F	G	H
AS-893 AK-893	3	in	6.00	7.50	2.00	7.00	1.12	0.75
		mm	152	190	51	178	29	19
AL-893	3	in	6.00	7.25	2.50	7.00	1.12	0.75
		mm	152	184	63	178	29	19

These dimensions are average and not for construction purposes. Certified prints on request.

**MOTOR SPEED PRODUCT LINE:
STEEL EXTERNALS — MAG DRIVE PUMPS
SERIES 893**

Section	1343
Page	1343.7
Issue	C

DIMENSIONS – AS, AK, AL SIZES – MD-B15 & B40 (B DRIVE)

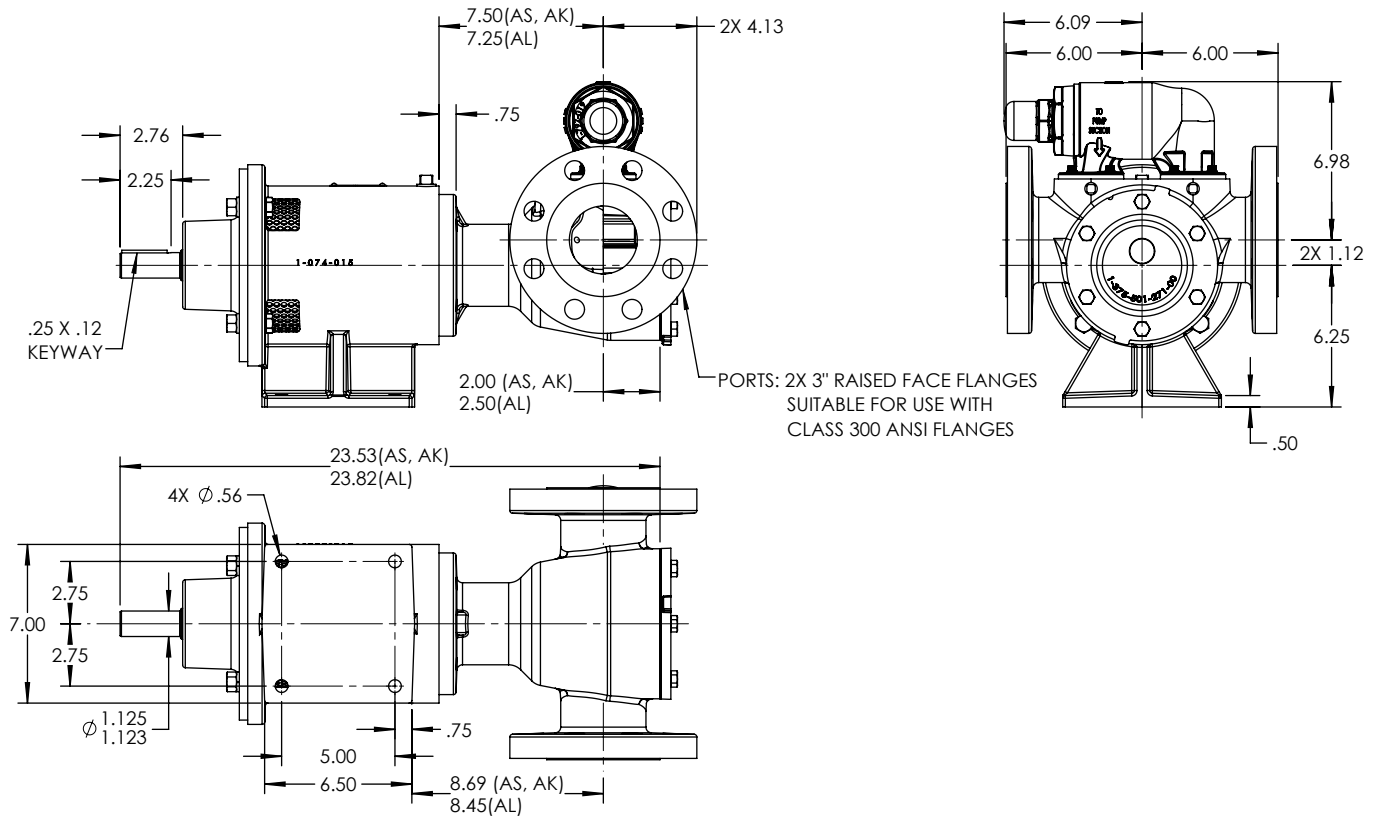

These dimensions are average and not for construction purposes. Certified prints on request.

Section	1343
Page	1343.8
Issue	C

**MOTOR SPEED PRODUCT LINE:
STEEL EXTERNALS — MAG DRIVE PUMPS
SERIES 893**

DIMENSIONS – AS, AK, AL SIZES – MD-C80 (B DRIVE)

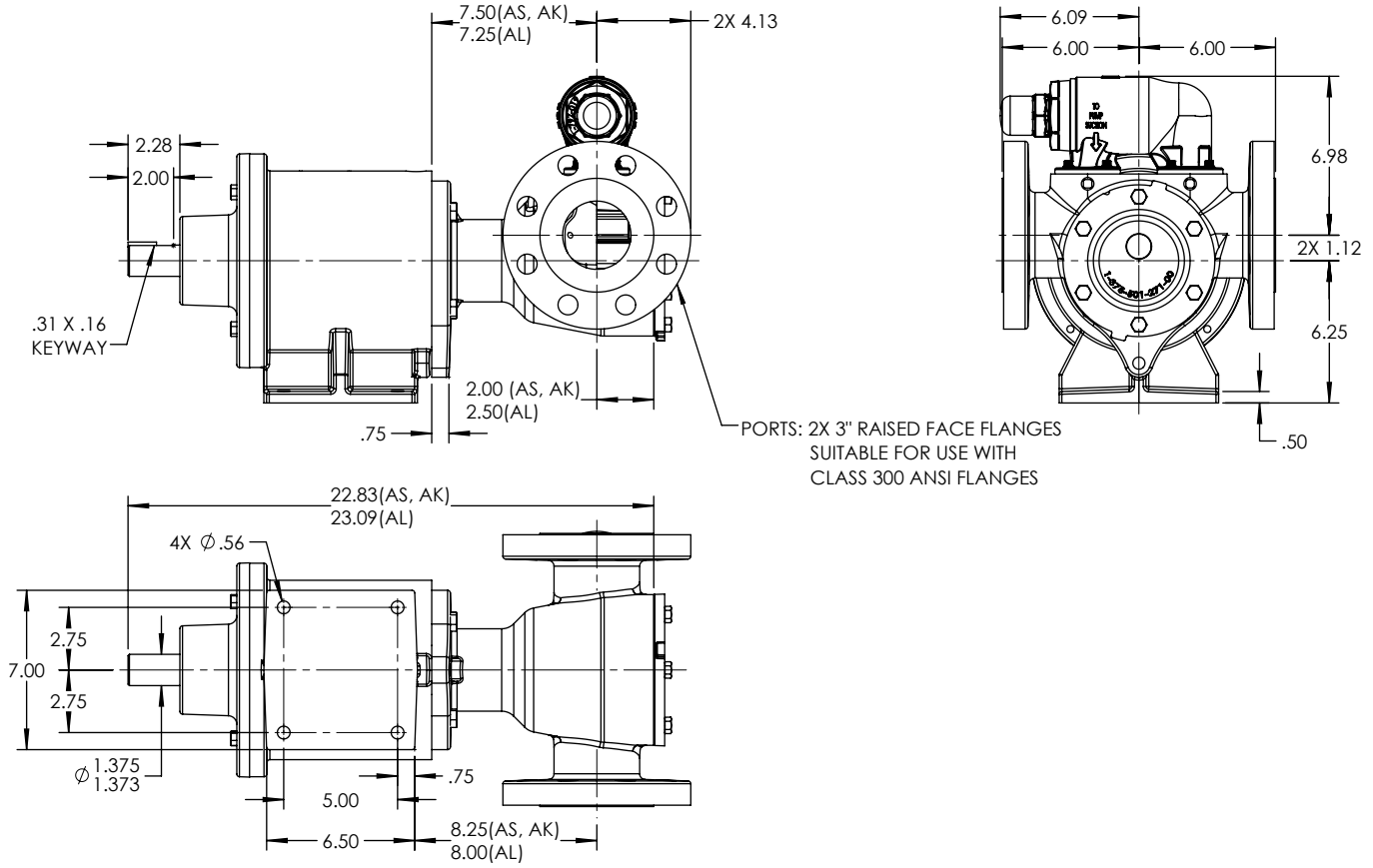

MOTOR SPEED PRODUCT LINE: STEEL EXTERNALS — MAG DRIVE PUMPS

SERIES 893

Section	1343
Page	1343.9
Issue	C

DIMENSIONS — AS, AK SIZES — MD-B15 & B40 (M DRIVE)

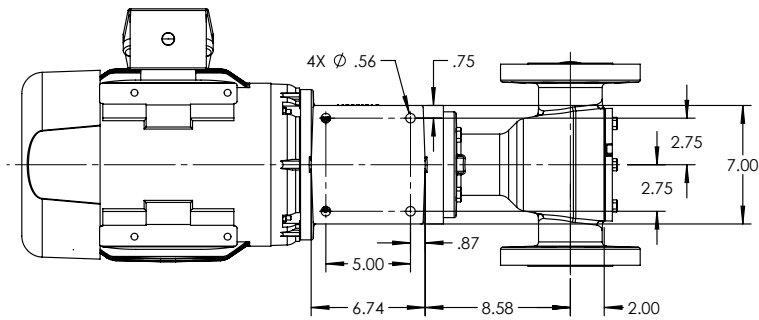
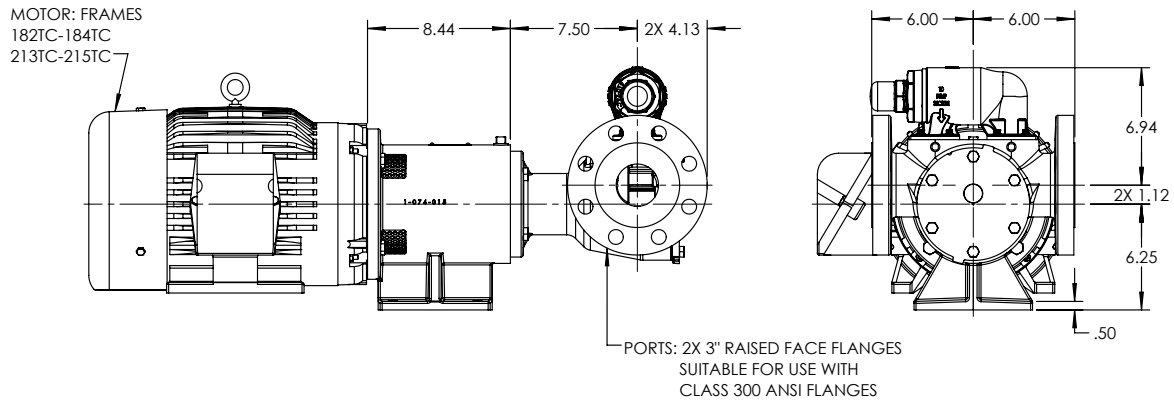

DIMENSIONS — AL SIZES — MD-B15 & B40 (M DRIVE)

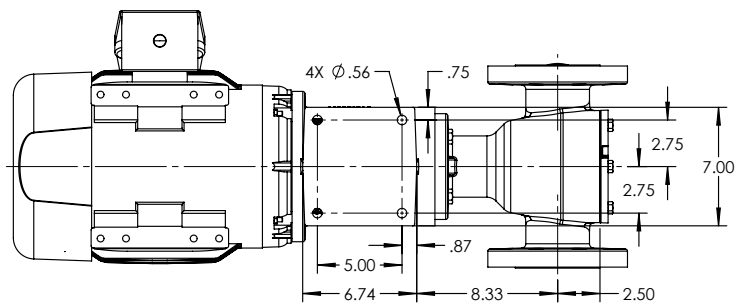
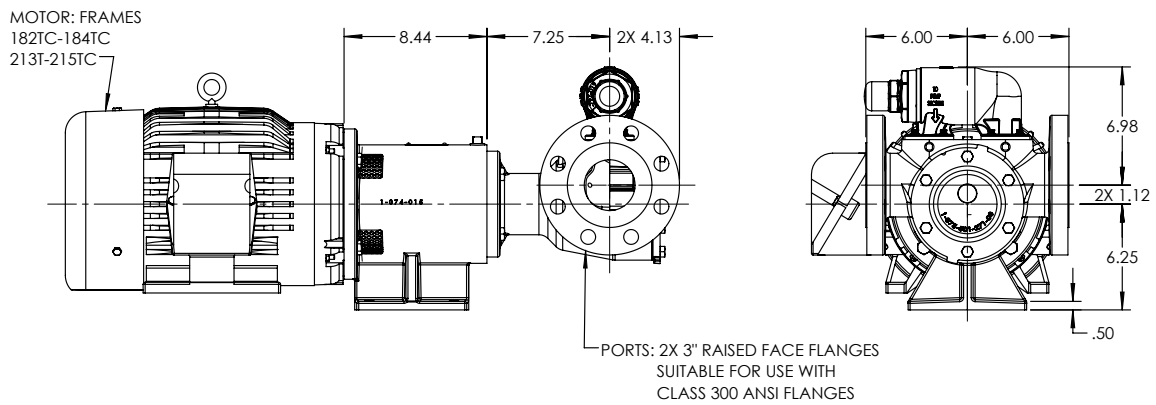

These dimensions are average and not for construction purposes. Certified prints on request.

Section	1343
Page	1343.10
Issue	C

**MOTOR SPEED PRODUCT LINE:
STEEL EXTERNALS — MAG DRIVE PUMPS
SERIES 893**

NPSH REQUIRED

Printed performance curves are not available.

Performance curves can be electronically generated with the Viking Pump Curve Generator on vikingpump.com.

NPSH_R data is not available on the Curve Generator.

NPSH (Net Positive Suction Head): The NPSH_R (Net Positive Suction Head Required by the pump) is given in the table below and applies for viscosities through 750 SSU. NPSH_A (Net Positive Suction Head – Available in the system) must be greater than the NPSH_R. For a complete explanation of NPSH, see Application Data Sheet AD-19.

FOR VISCOSITIES UP TO 750 SSU – See NPSH_R table below.

NPSH_R for high viscosities can be estimated using the following method:

1. Calculate line loss for a 1 foot long pipe of a diameter matching the pump inlet port size. Use your flow rate and max viscosity.
2. Convert this value into Feet of Liquid (S.G. 1.0)
3. Add this value to the NPSH_R value in the chart below.

NPSH_R – FEET OF LIQUID (Specific Gravity 1.0), Viscosities up to 750 SSU

PUMP SIZE	PUMPS SPEED, RPM					
	840	780	950	1150	1450	1750
GG	2.2	2.6	3.1	3.9	5.6	7.6
HJ, HL	2.8	3.4	4.5	6.2	9.5	13.5
AS, AK, AL	3.9	5.5	7.7	11.2	—	—

**MOTOR SPEED PRODUCT LINE:
STEEL EXTERNALS — MAG DRIVE PUMPS
SERIES 893**

Section	1343
Page	1343.11
Issue	C

**SELECTING THE CORRECT
VIKING MAG DRIVE® COUPLING**

1. Find pump HP and speed from the performance curves, which can be electronically generated with the Viking Pump Selector Program, located on www.vikingpump.com.

2. Calculate the application torque (T), using this formula:

$$T \text{ (FT-LB)} = \frac{\text{HP}}{\text{SPEED}} \times 5252$$

3. Select the temperature correction factor (TCF) from Table 1 or Table 2.

STANDARD NEODYMIUM MAGNETS (For Application Temperatures Below 225°F.)							
Application Temp. (°F)	AMB	100	125	150	175	200	225
TCF	1.0	.94	.88	.82	.76	.70	.64

Table 1: Temperature Correction Factors

OPTIONAL SAMARIUM COBALT MAGNETS (For Application Temperatures Above 225°F.)					
Application Temp. (°F)	175	200	300	400	500
TCF	.74	.73	.69	.63	.59

Table 2: Temperature Correction Factors

4. Divide calculated application torque by TCF to get adjusted application torque.

5. Select coupling with rating equal to or greater than “adjusted application torque” from Table 3.

MAGNETIC COUPLING TORQUE RATING TABLE	
Coupling Size	Torque (FT-LBS)
MD-A4	4
MD-A9	9
MD-B40	40
MD-C80	80

Table 3

EXAMPLE 1

1. A GG893 is required to pump 100 SSU liquid at 1750 RPM, 50 PSI differential pressure.

Temperature is 100°F.

From the pump selector, required HP is 0.85.

2. Calculate torque (T).

$$\begin{aligned} \text{TORQUE (T)} &= \frac{0.85}{1750} \times 5252 \\ &= 2.6 \text{ FT-LB} \end{aligned}$$

3. From the temperature correction factor table, the correction factor (TCF) = 0.94.

4. Calculate adjusted application torque.

$$\begin{aligned} \text{ADJUSTED APPLICATION TORQUE} &= \frac{2.6}{0.94} \\ &= 2.8 \text{ FT-LB} \end{aligned}$$

5. Select coupling.

A STANDARD NEODYMIUM MD-A4 COUPLING IS THE PROPER SELECTION

EXAMPLE 2

1. AN AL893 is required to pump 38 SSU liquid at 1150 RPM, 50 PSI differential pressure.

Temperature is 300°F.

From the pump selector, required HP is 3.7.

2. Calculate torque (T).

$$\begin{aligned} \text{TORQUE (T)} &= \frac{3.7}{1150} \times 5252 \\ &= 16.9 \text{ FT-LB} \end{aligned}$$

3. From the temperature correction factor table, the correction factor (TCF) = 0.69.

4. Calculate adjusted application torque.

$$\begin{aligned} \text{ADJUSTED APPLICATION TORQUE} &= \frac{16.9}{0.69} \\ &= 24.5 \text{ FT-LB} \end{aligned}$$

5. Select coupling.

AN MD-B40 WITH OPTIONAL SAMARIUM COBALT MAGNETS IS THE PROPER SELECTION