

CURVES
CAC2000 R1

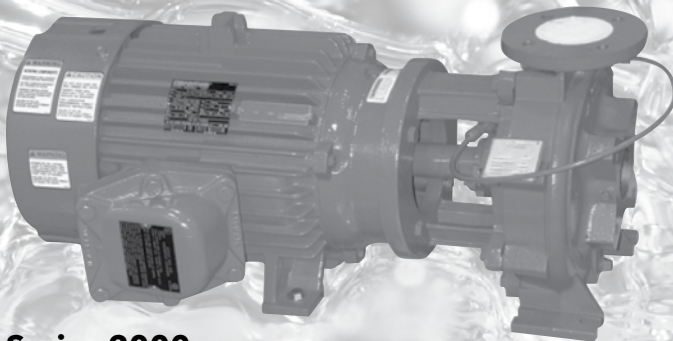

**Series 2000
Closed Coupled**

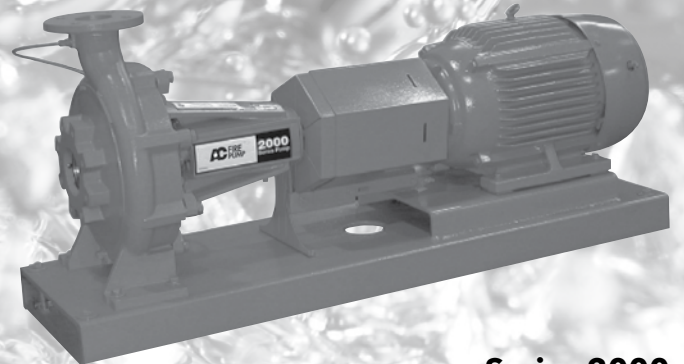

**Series 2000
Frame Mounted**

Series A-C 2000 60 Hz

CLOSED COUPLED & FRAME MOUNTED CENTRIFUGAL PUMP PERFORMANCE CURVES

TABLE OF CONTENTS

Useful Pump Formulas	3	2 x 1.5 x 9	23
60 Hz Range Curves	4	3 x 2.5 x 9	23
Selection Charts	5	3 x 2.5 x 11	24
		3 x 2.5 x 13	24
1750 RPM PUMP CURVES		3 x 2 x 10	25
1.5 x 1.5 x 9	6	3 x 2 x 11	25
2.5 x 2 x 6.5L.....	6	4 x 3 x 6.5	26
2.5 x 2 x 6.5S.....	7	4 x 3 x 9	26
2.5 x 2 x 9L	7	4 x 3 x 11	27
2.5 x 2 x 9S	8	4 x 3 x 13	27
2 x 1.5 x 6.5	8	4 x 4 x 11	28
2 x 1.5 x 9	9	6 x 4 x 9	28
3 x 2.5 x 9	9	6 x 4 x 13	29
3 x 2.5 x 11	10	6 x 6 x 9.5	29
3 x 2.5 x 13	10	6 x 6 x 11	30
3 x 2 x 6.5L	11	6 x 6 x 13L.....	30
3 x 2 x 6.5S	11	6 x 6 x 13S.....	31
3 x 2 x 9	12	8 x 6 x 9.5	31
3 x 2 x 10	12	8 x 6 x 11	32
3 x 2 x 11	13	8 x 6 x 13	32
4 x 3 x 6.5	13	10 x 8 x 13.....	33
4 x 3 x 9	14		
4 x 3 x 11	14	3500 RPM PUMP CURVES	
4 x 3 x 13	15	1.5 x 1.5 x 9	34
4 x 4 x 11	15	2.5 x 2 x 6.5L.....	34
6 x 4 x 9	16	2.5 x 2 x 6.5S.....	35
6 x 4 x 13	16	2.5 x 2 x 9L	35
6 x 6 x 9.5	17	2.5 x 2 x 9S	36
6 x 6 x 11	17	2 x 1.5 x 6.5	36
6 x 6 x 13L.....	18	2 x 1.5 x 9	37
6 x 6 x 13S.....	18	3 x 2.5 x 9	37
8 x 6 x 9.5	19	3 x 2 x 6.5L	38
8 x 6 x 11	19	3 x 2 x 6.5S	38
8 x 6 x 13	20	3 x 2 x 9	39
10 x 8 x 13.....	20	3 x 2 x 10	39
		4 x 3 x 6.5	40
		4 x 3 x 9	40
1150 RPM PUMP CURVES			
1.5 x 1.5 x 9	21		
2.5 x 2 x 6.5L.....	21		
2.5 x 2 x 6.5S.....	22		
2 x 1.5 x 6.5	22		

USEFUL PUMP FORMULAS

$$\text{Pressure (PSI)} = \frac{\text{Head (feet)} \times \text{Specific Gravity}}{2.31}$$

$$\text{Head (feet)} = \frac{\text{Pressure (PSI)} \times 2.31}{\text{Specific Gravity}}$$

$$\text{Vacuum (in. of mercury)} = \frac{\text{Dynamic Suction Lift (feet)} \times .883}{\text{Specific Gravity}}$$

$$\text{Horsepower (brake)} = \frac{\text{GPM} \times \text{Head (feet)} \times \text{Specific Gravity}}{3960 \times \text{Pump Efficiency}}$$

$$\text{Horsepower (water)} = \frac{\text{GPM} \times \text{Head (feet)} \times \text{Specific Gravity}}{3960}$$

$$\text{Efficiency (pump)} = \frac{\text{Horsepower (water)}}{\text{Horsepower (brake)}} \times 100 \text{ per cent}$$

$$\text{NPSH (available)} = \text{Positive Factors} - \text{Negative Factors}$$

AFFINITY LAWS: Effect of change of speed or impeller diameter on centrifugal pumps

	GPM Capacity	Feet Head	BHP
Impeller Diameter Change	$Q_2 = \frac{D_2}{D_1} Q_1$	$H_2 = \left(\frac{D_2}{D_1}\right)^2 H_1$	$P_2 = \left(\frac{D_2}{D_1}\right)^3 P_1$
Speed Change	$Q_2 = \frac{\text{RPM}_2}{\text{RPM}_1} Q_1$	$H_2 = \left(\frac{\text{RPM}_2}{\text{RPM}_1}\right)^2 H_1$	$P_2 = \left(\frac{\text{RPM}_2}{\text{RPM}_1}\right)^3 P_1$

Where Q = GPM, H = Head, P = BHP, D = Impeller Diameter, RPM = Pump Speed

60 HZ FULL HYDRAULIC RANGE CURVES

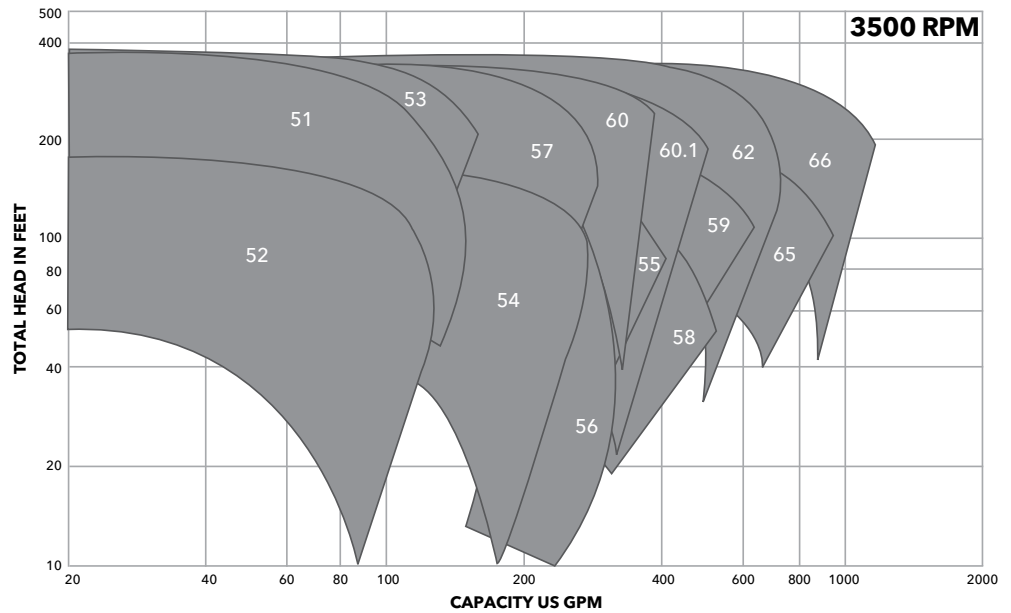
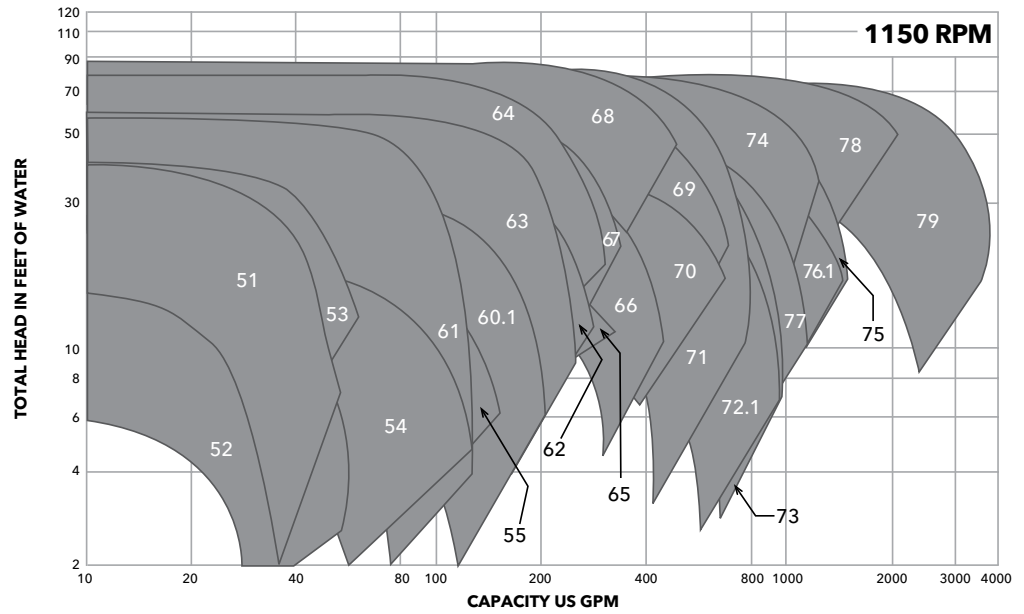
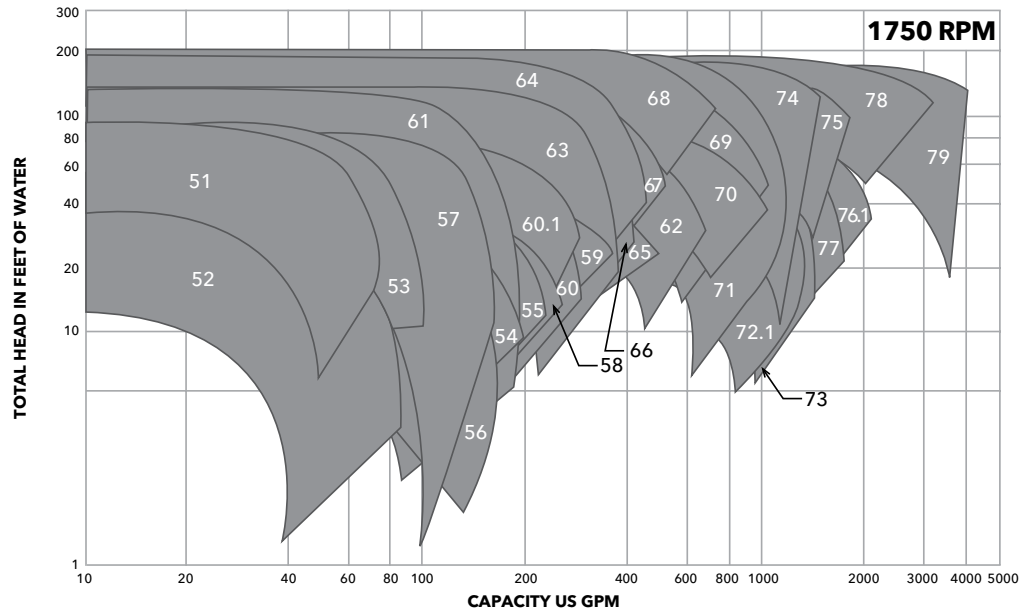

SERIES A-C 2000 - 60 Hz

1750 RPM SELECTION CHART

Key No.	Pump Size and Type	Key No.	Pump Size and Type
51	1.5x1.5x9	65	4x3x6.5
52	2x1.5x6.5	66	4x3x9
53	2x1.5x9	67	4x3x11
54	2.5x2x6.5S	68	4x3x13
55	2.5x2x6.5L	69	4x4x11
56	2.5x2x9S	70	6x4x9
57	2.5x2x9L	71	6x4x13
58	3x2x6.5S	72.1	6x6x9.5
59	3x2x6.5L	73	6x6x11
60	3x2x9	74	6x6x13S
60.1	3x2x10	75	6x6x13L
61	3x2x11	76.1	8x6x9.5
62	3x2.5x9	77	8x6x11
63	3x2.5x11	78	8x6x13
64	3x2.5x13	79	10x8x13

3500 RPM SELECTION CHART

Key No.	Pump Size and Type	Key No.	Pump Size and Type
51	1.5x1.5x9	58	3x2x6.5S
52	2x1.5x6.5	59	3x2x6.5L
53	2x1.5x9	60	3x2x9
54	2.5x2x6.5S	60.1	3x2x10
55	2.5x2x6.5L	62	3x2.5x9
56	2.5x2x9S	65	4x3x6.5
57	2.5x2x9L	66	4x3x9

1150 RPM SELECTION CHART

Key No.	Pump Size and Type	Key No.	Pump Size and Type
51	1.5x1.5x9	68	4x3x13
52	2x1.5x6.5	69	4x4x11
53	2x1.5x9	70	6x4x9
54	2.5x2x6.5S	71	6x4x13
55	2.5x2x6.5L	72.1	6x6x9.5
60.1	3x2x10	73	6x6x11
61	3x2x11	74	6x6x13S
62	3x2.5x9	75	6x6x13L
63	3x2.5x11	76.1	8x6x9.5
64	3x2.5x13	77	8x6x11
65	4x3x6.5	78	8x6x13
66	4x3x9	79	10x8x13
67	4x3x11		

SERIES A-C 2000 - 60 Hz

1750 RPM PUMP CURVES

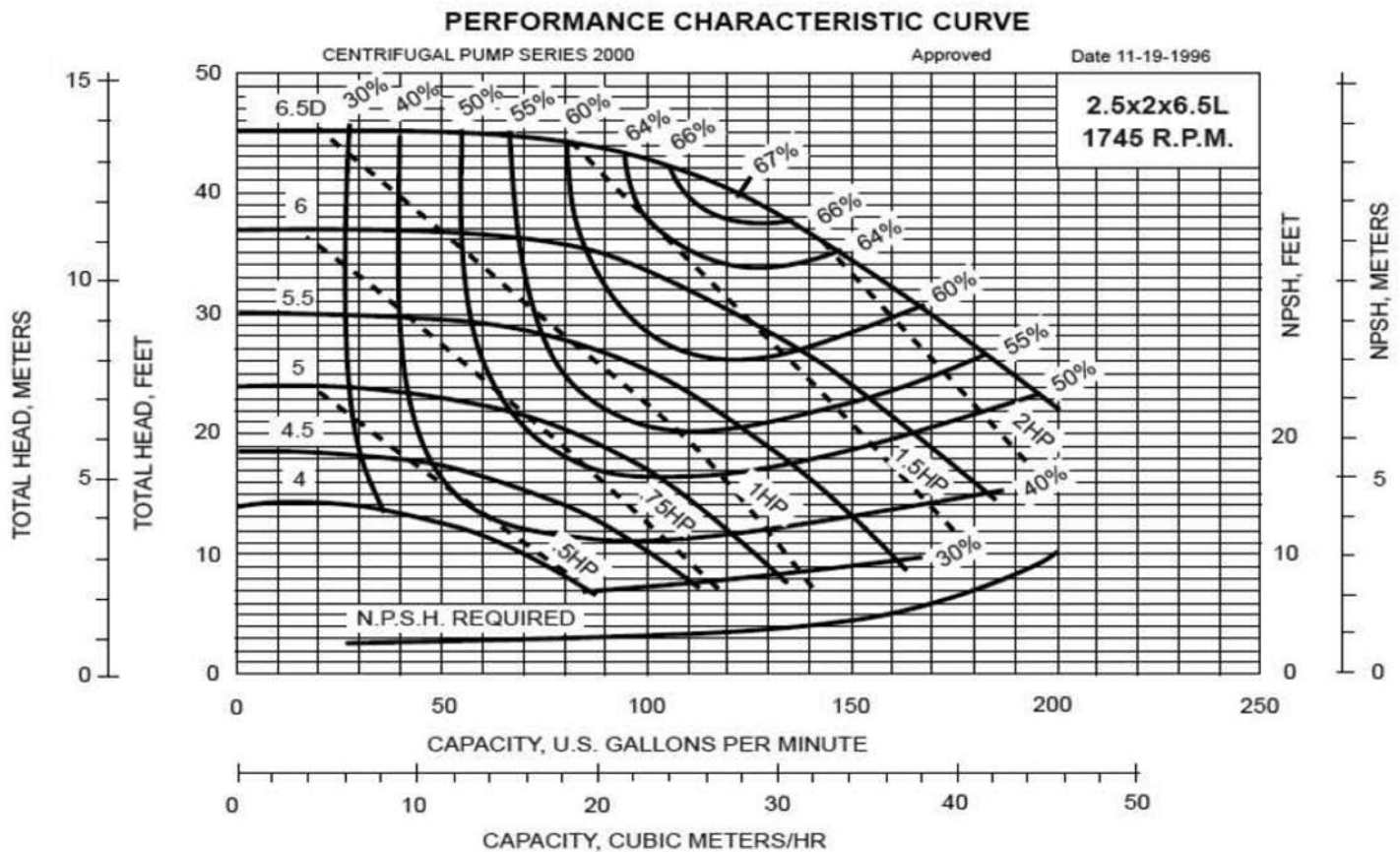
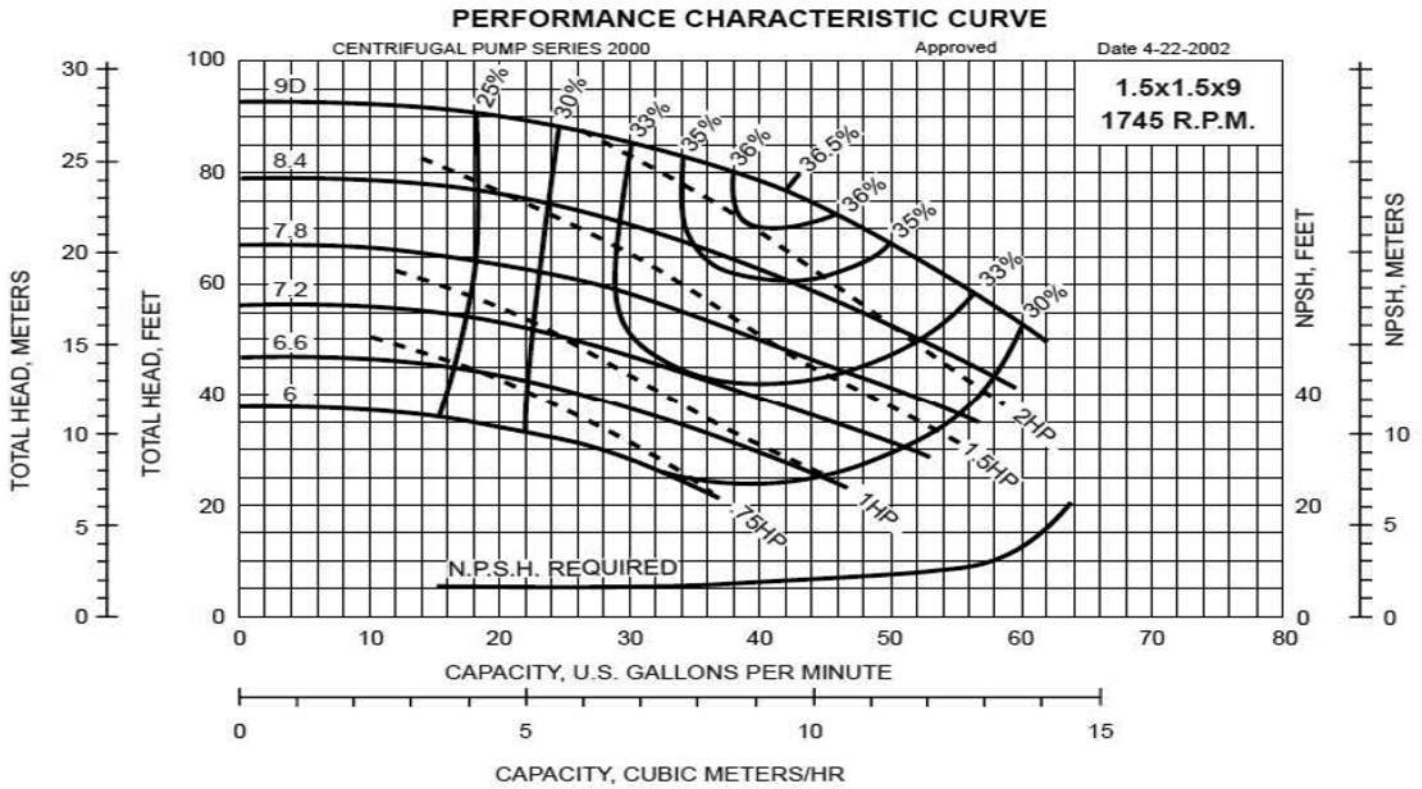

SERIES A-C 2000 - 60 Hz

1750 RPM PUMP CURVES

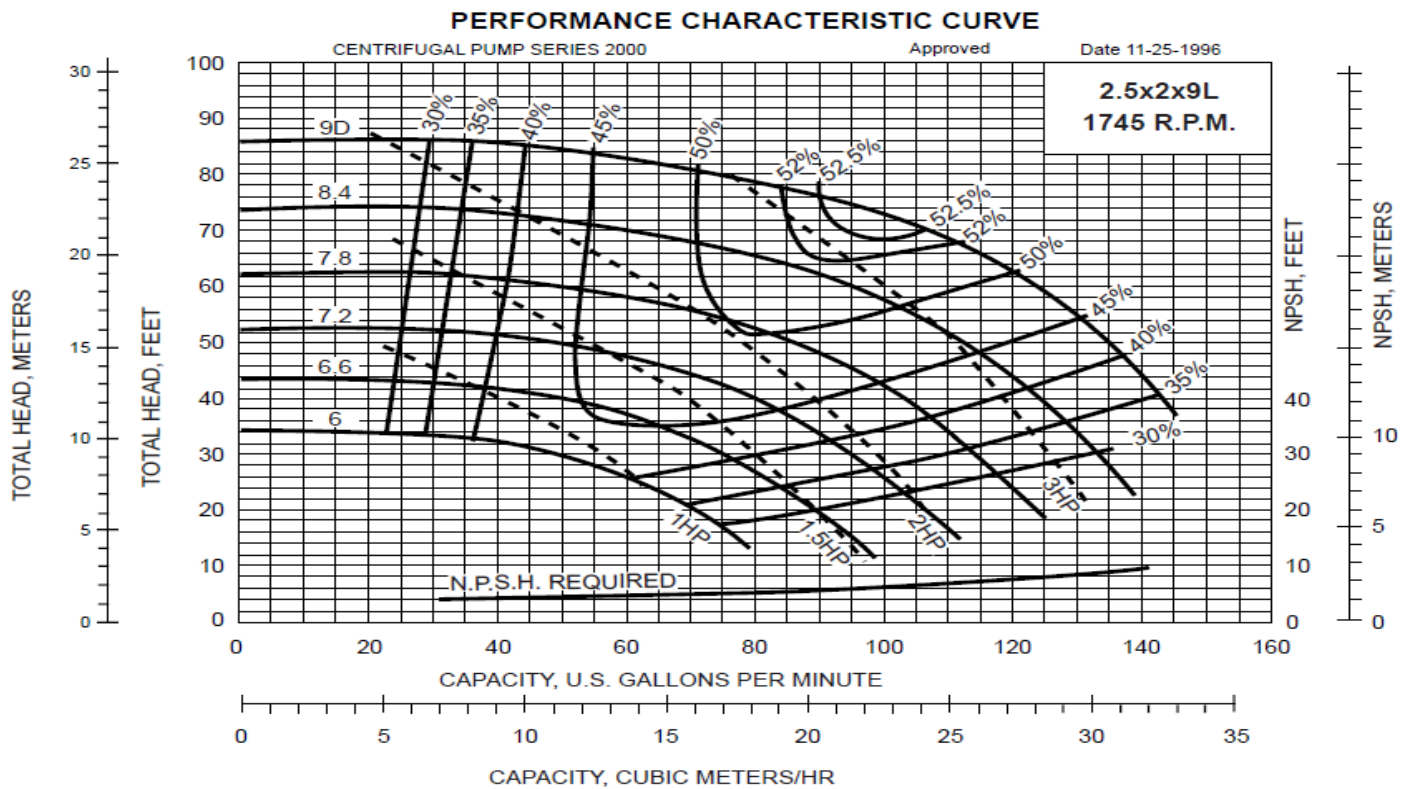
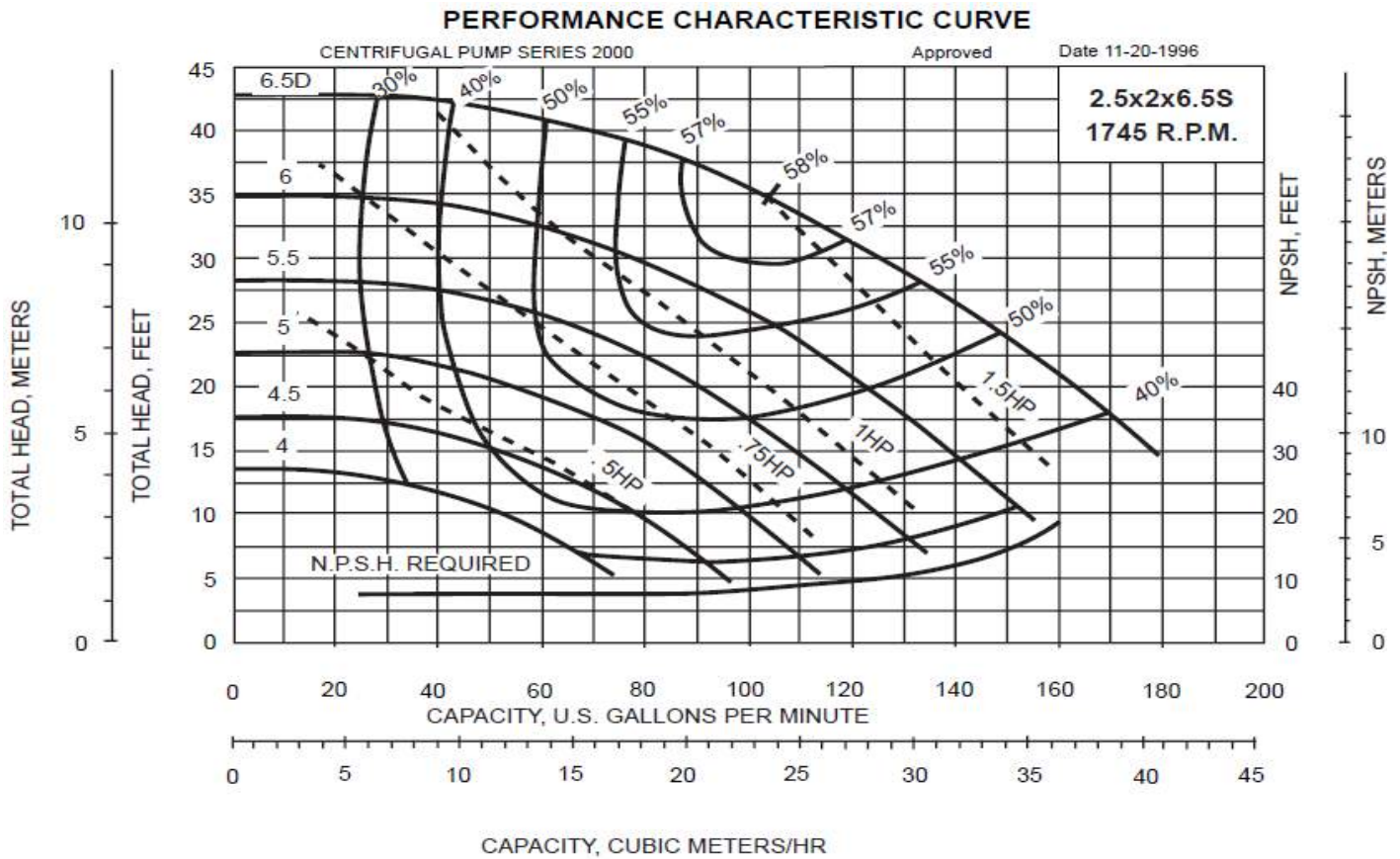

SERIES A-C 2000 - 60 Hz

1750 RPM PUMP CURVES

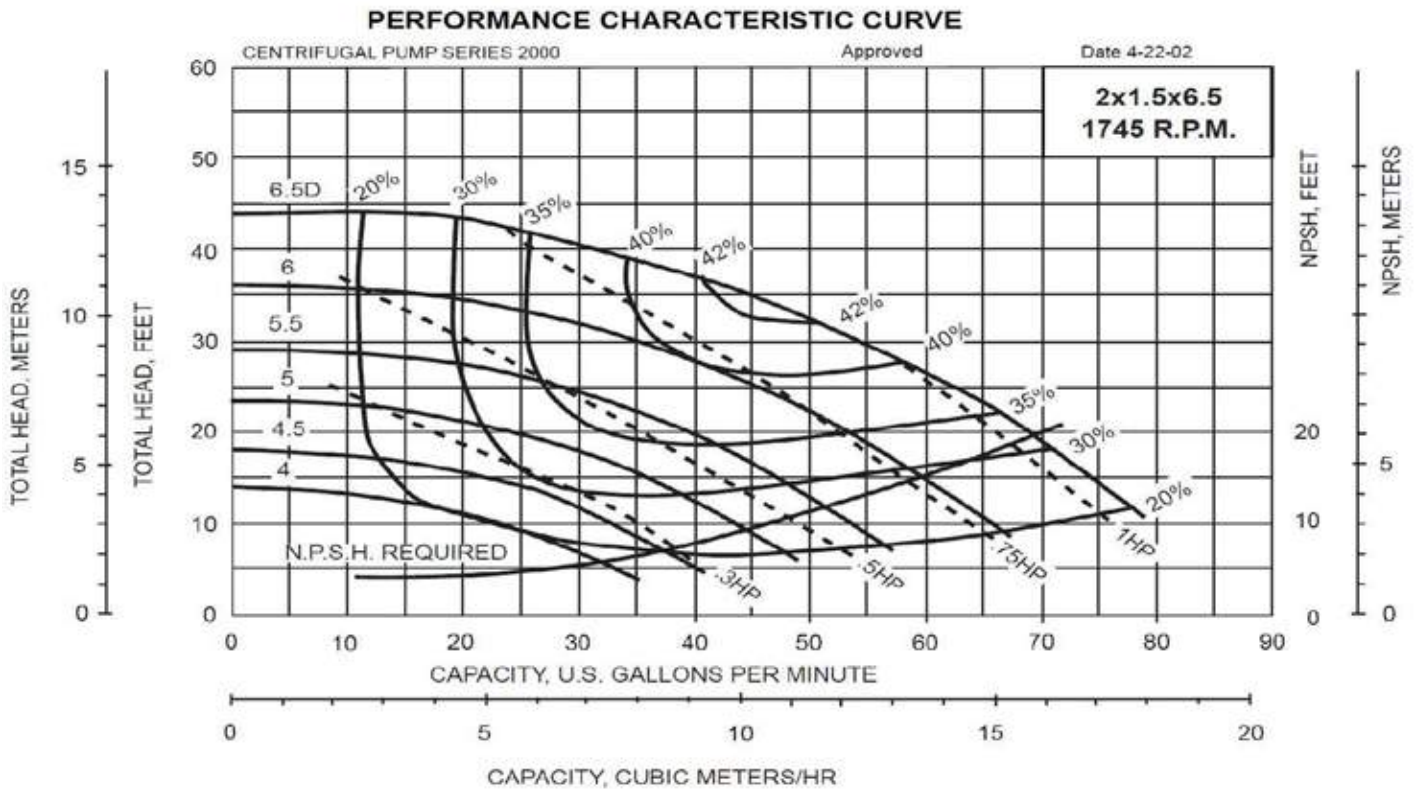
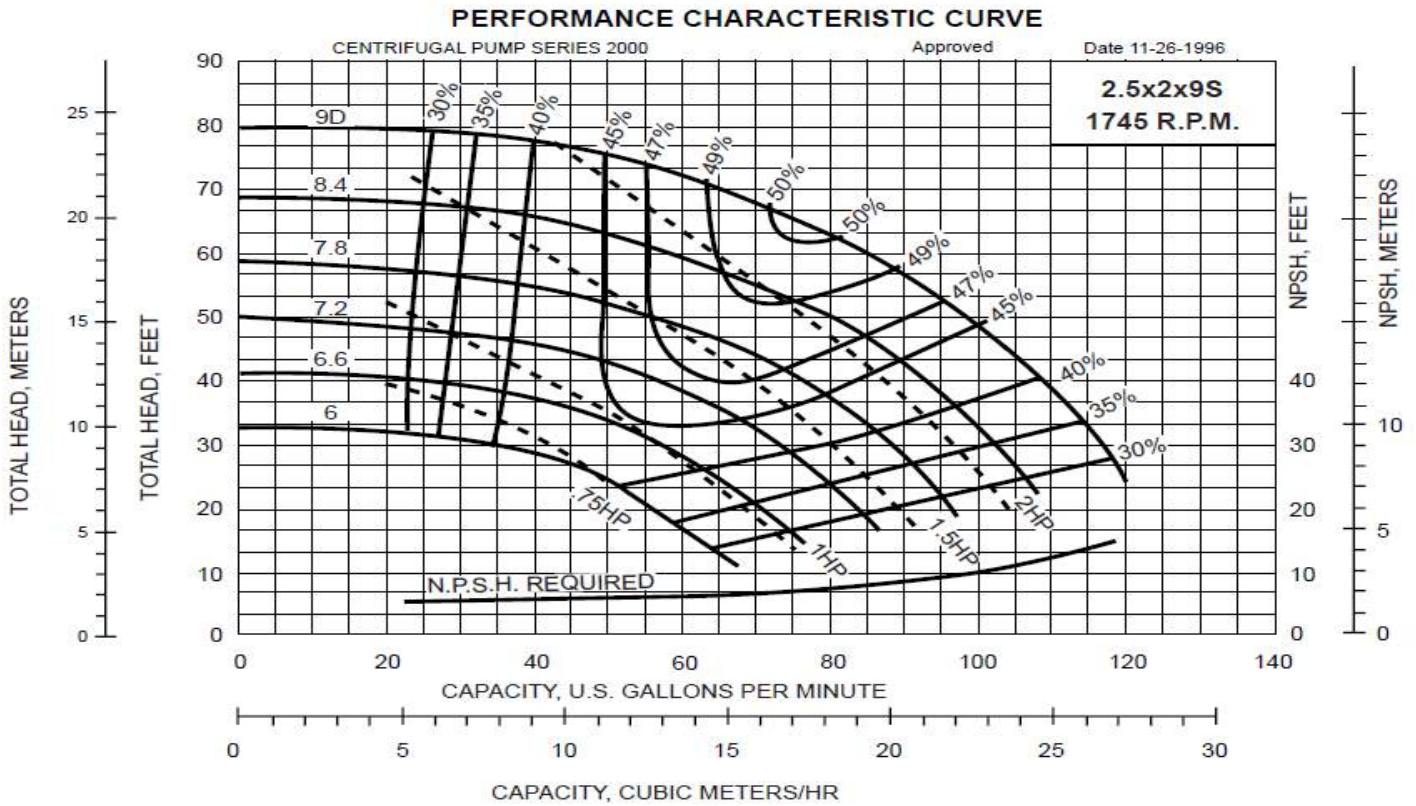

SERIES A-C 2000 - 60 Hz

1750 RPM PUMP CURVES

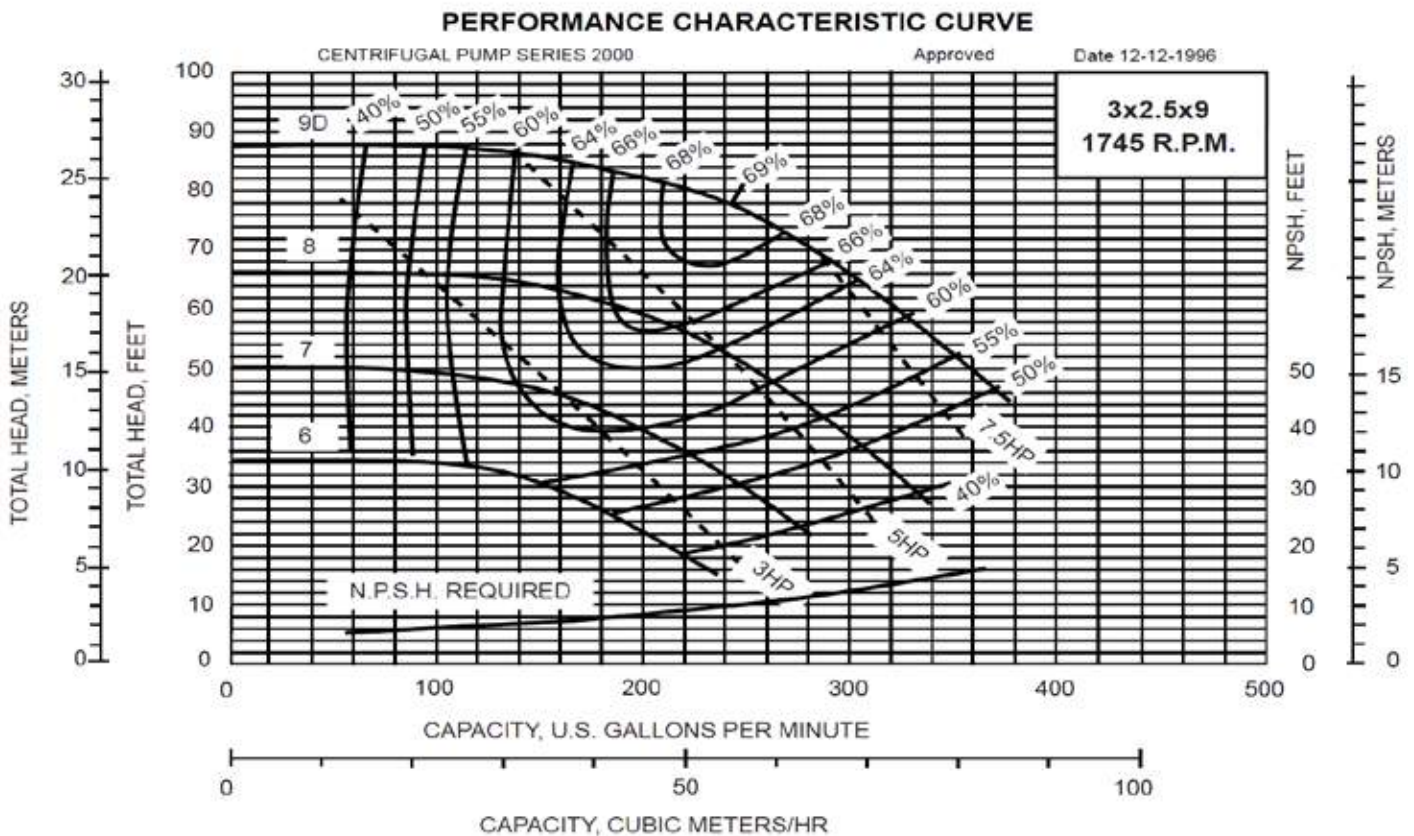
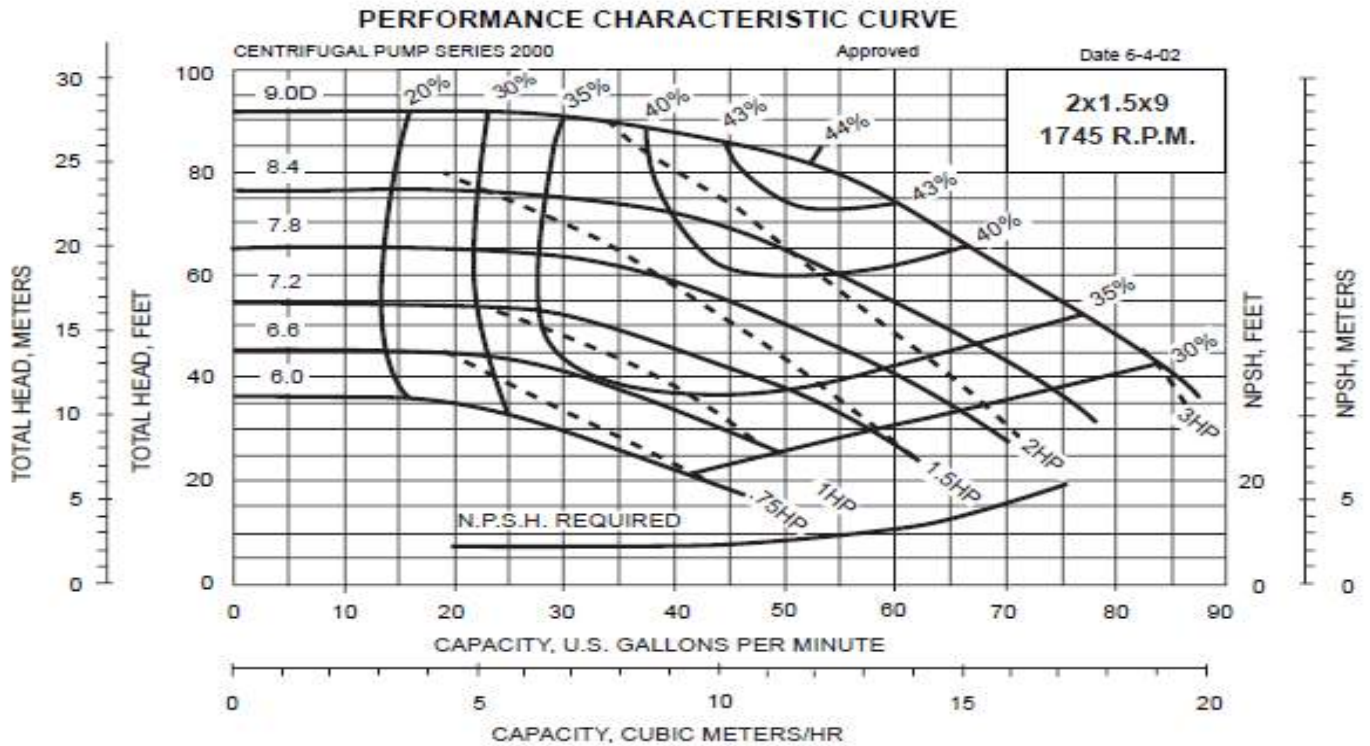

SERIES A-C 2000 - 60 Hz

1750 RPM PUMP CURVES

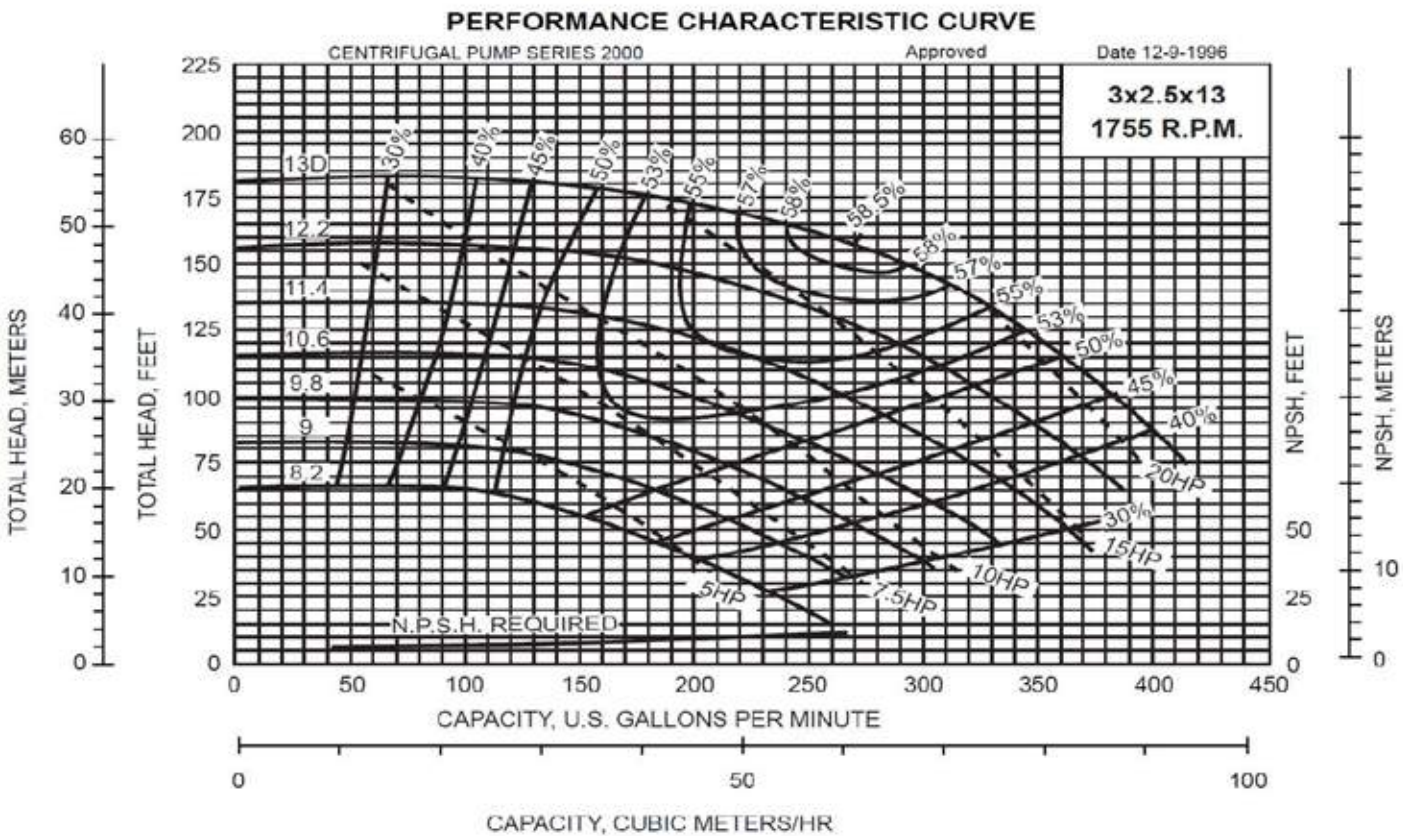
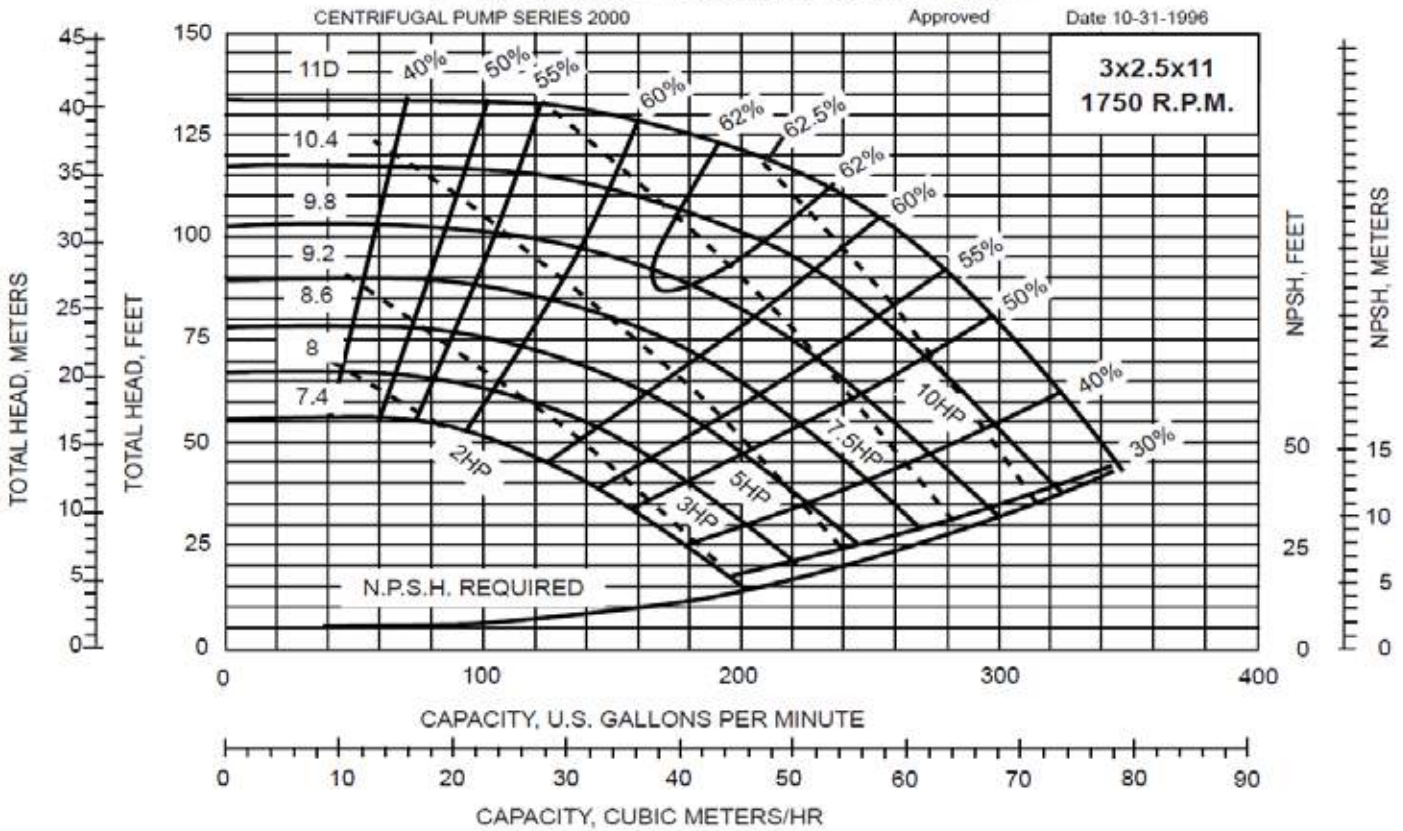

SERIES A-C 2000 - 60 Hz

1750 RPM PUMP CURVES

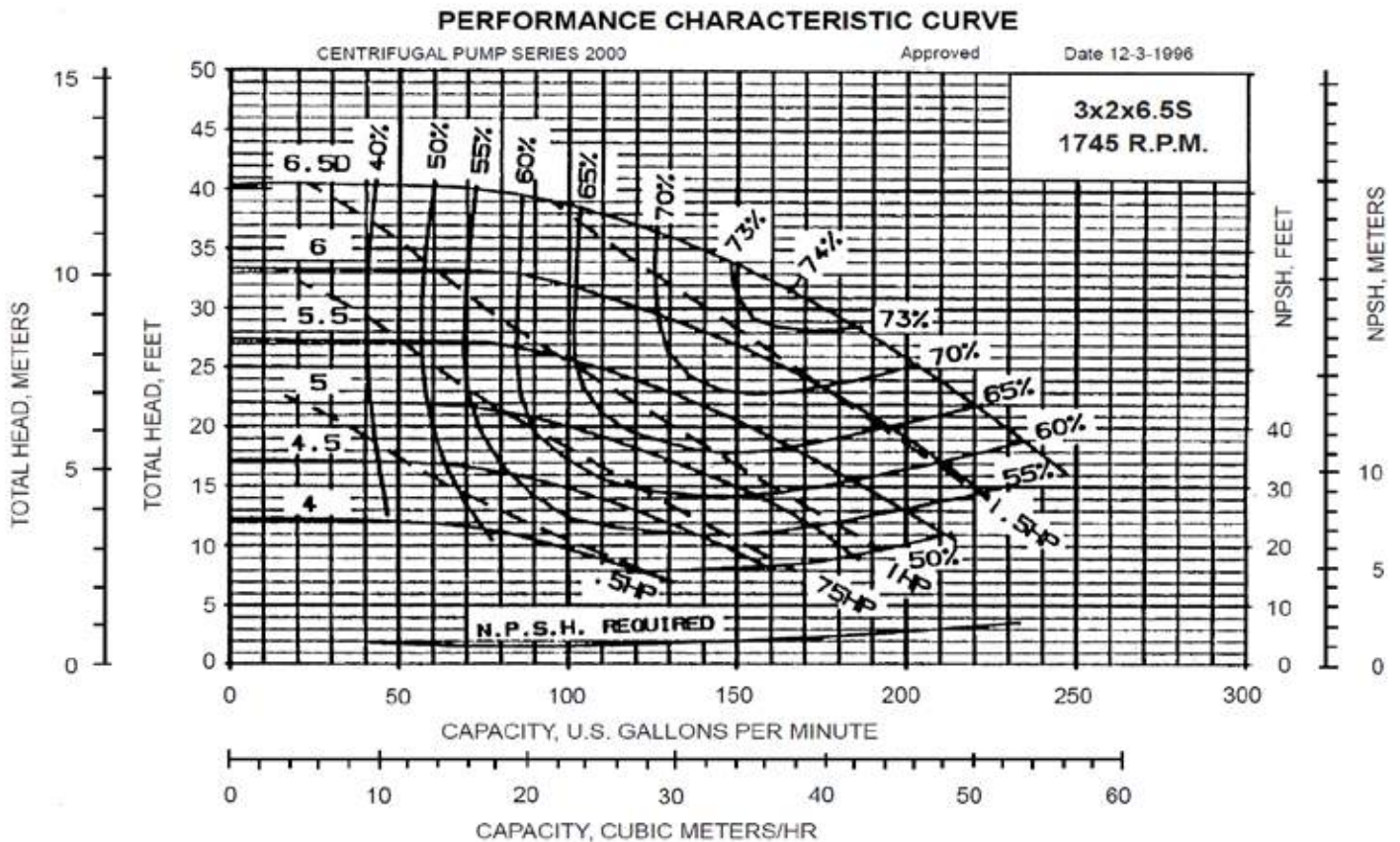
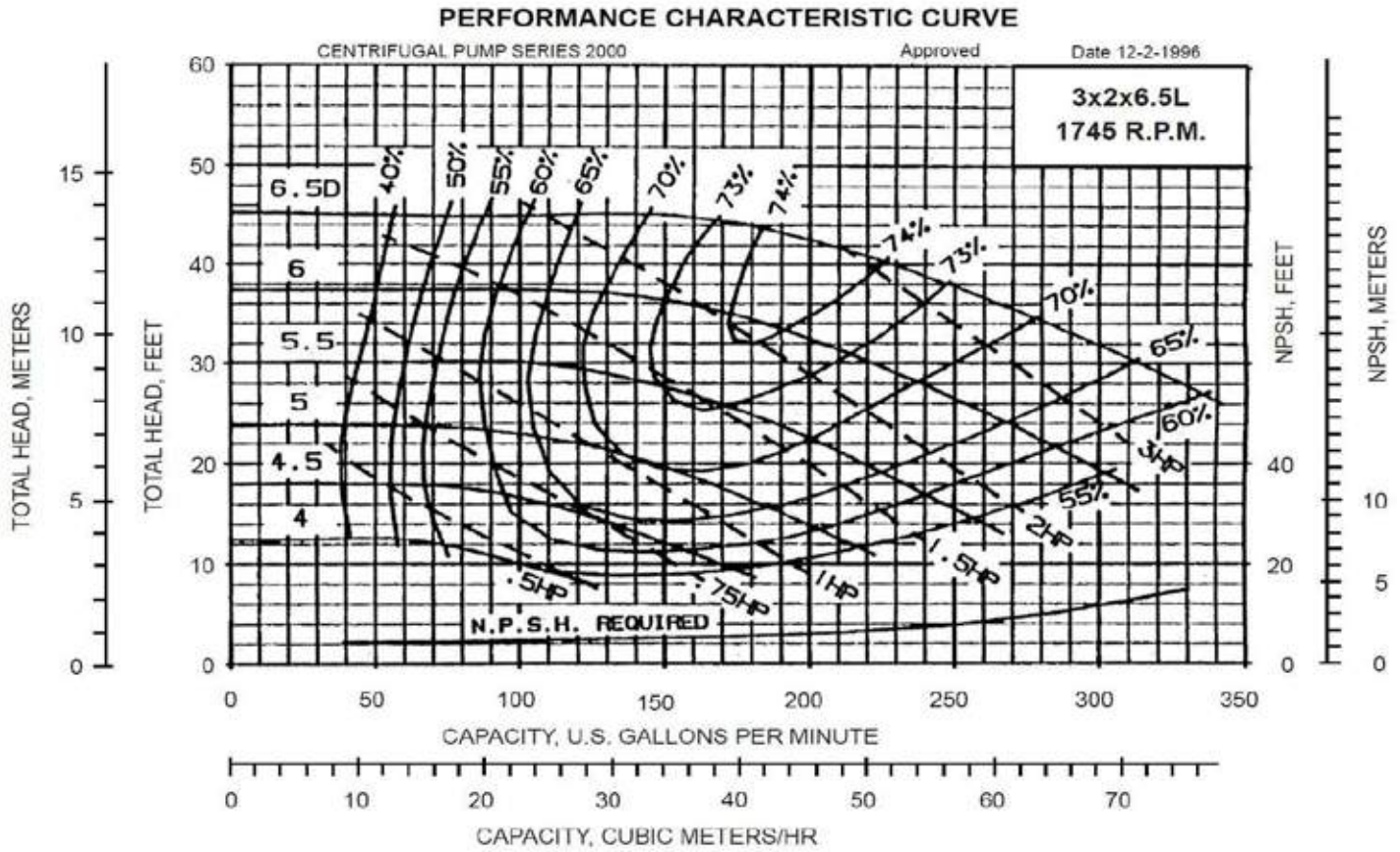

SERIES A-C 2000 - 60 Hz

1750 RPM PUMP CURVES

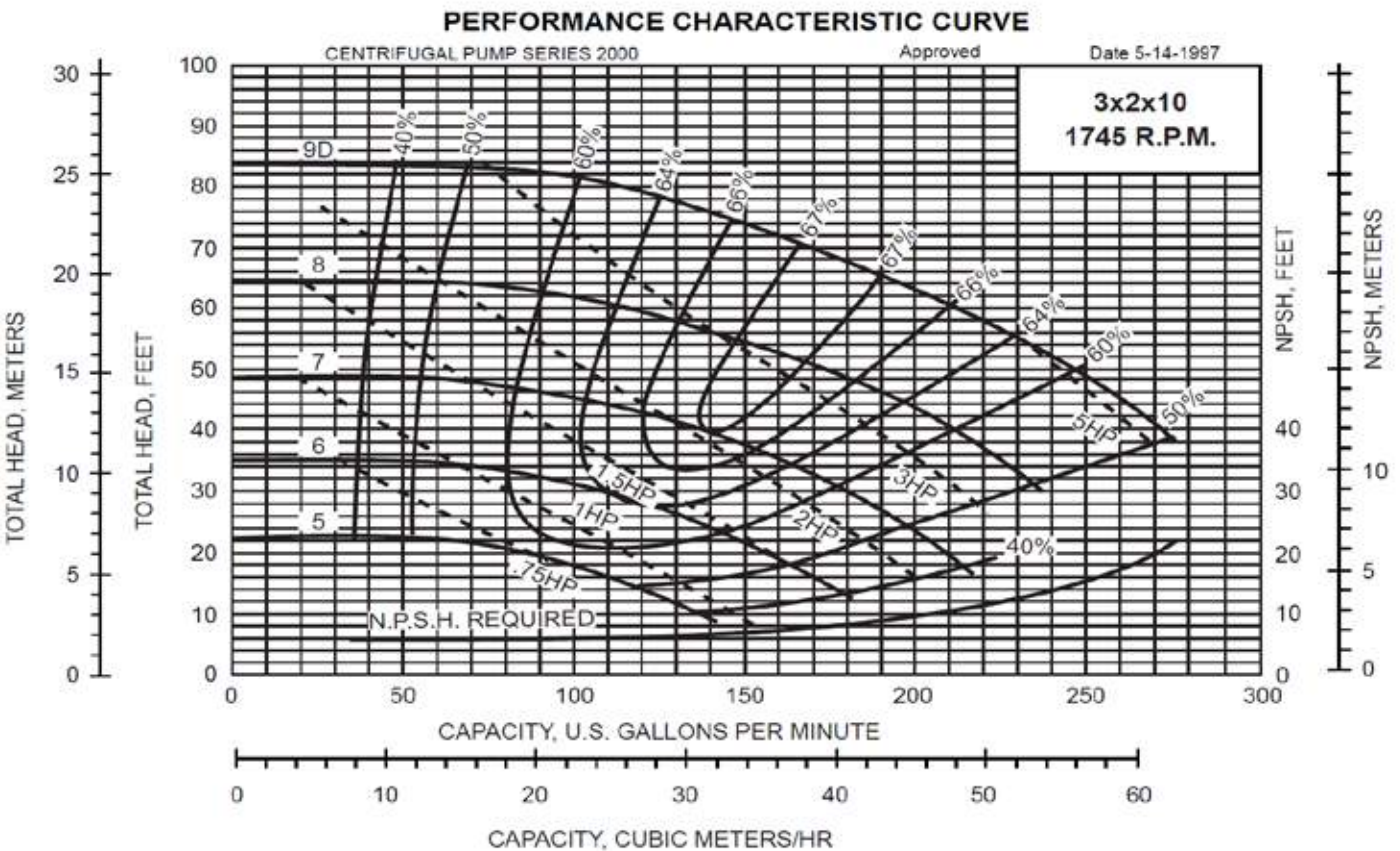
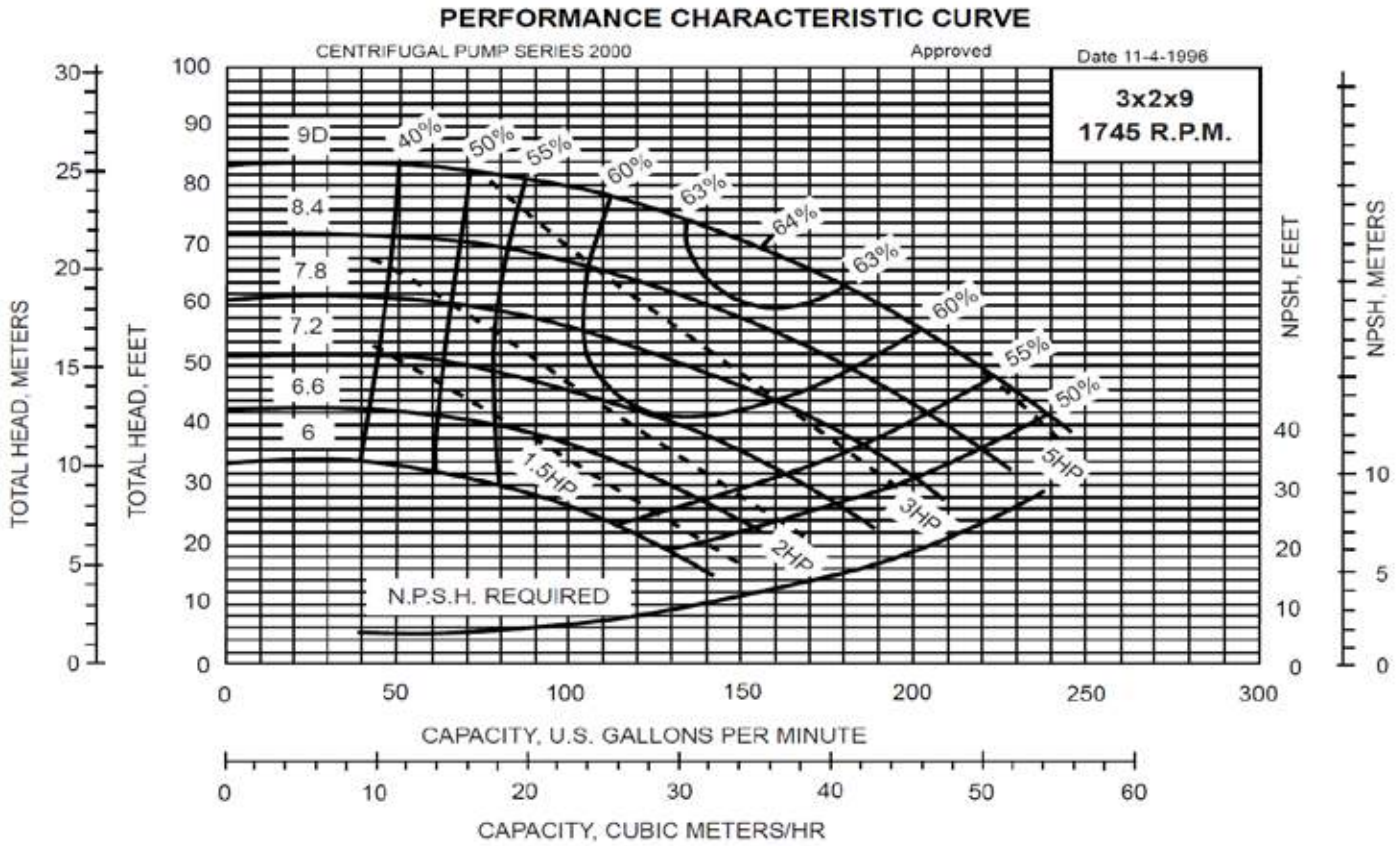

SERIES A-C 2000 - 60 Hz

1750 RPM PUMP CURVES

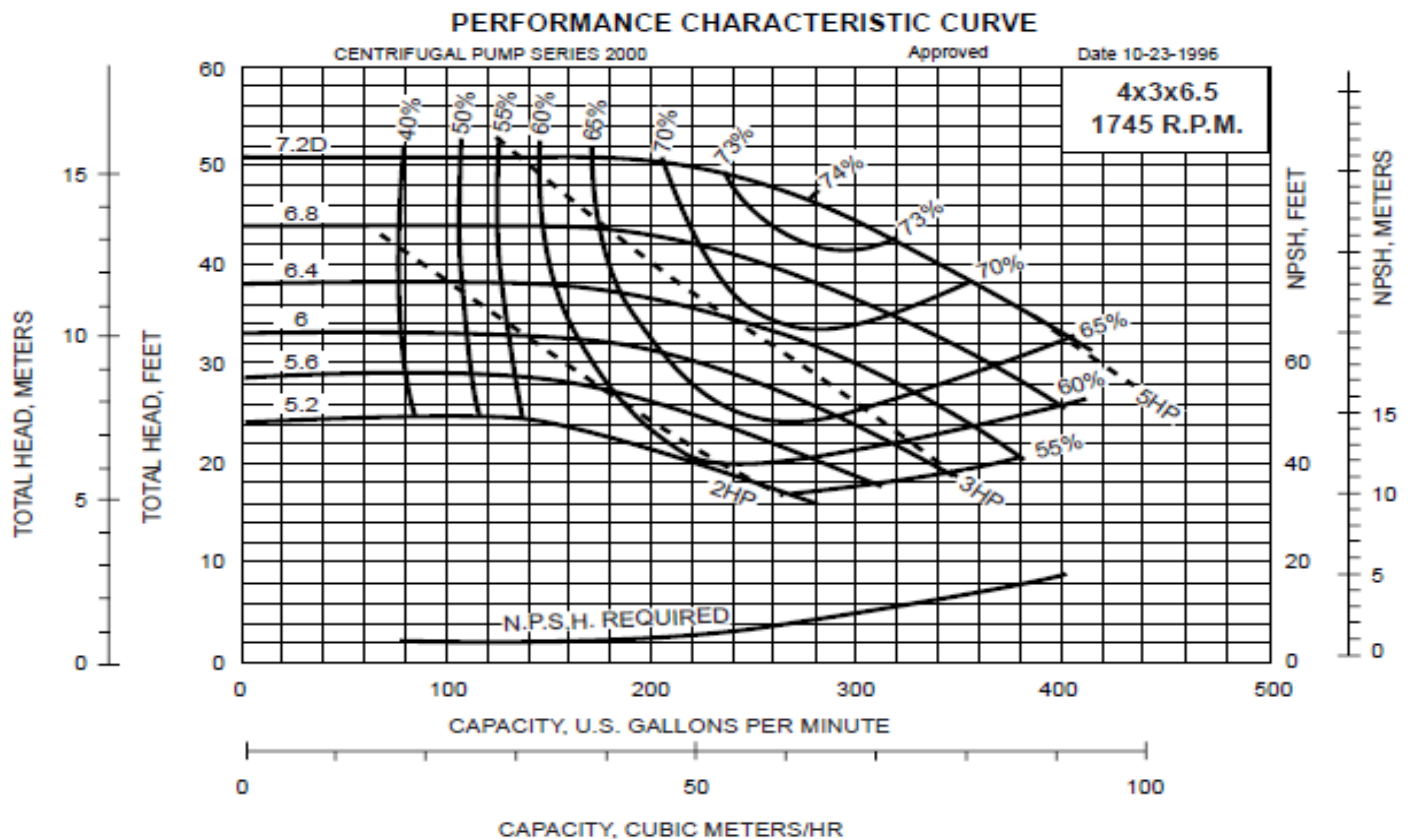
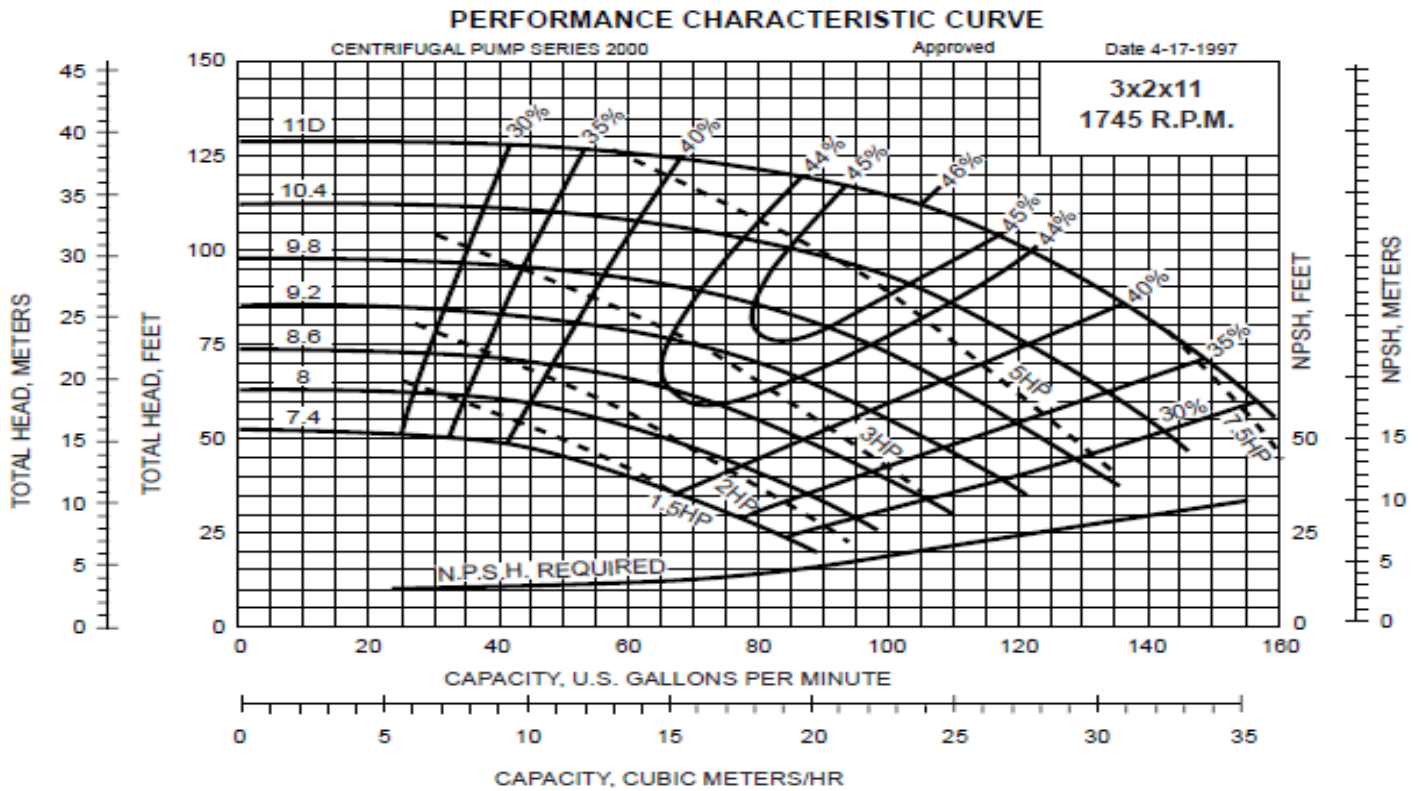

SERIES A-C 2000 - 60 Hz

1750 RPM PUMP CURVES

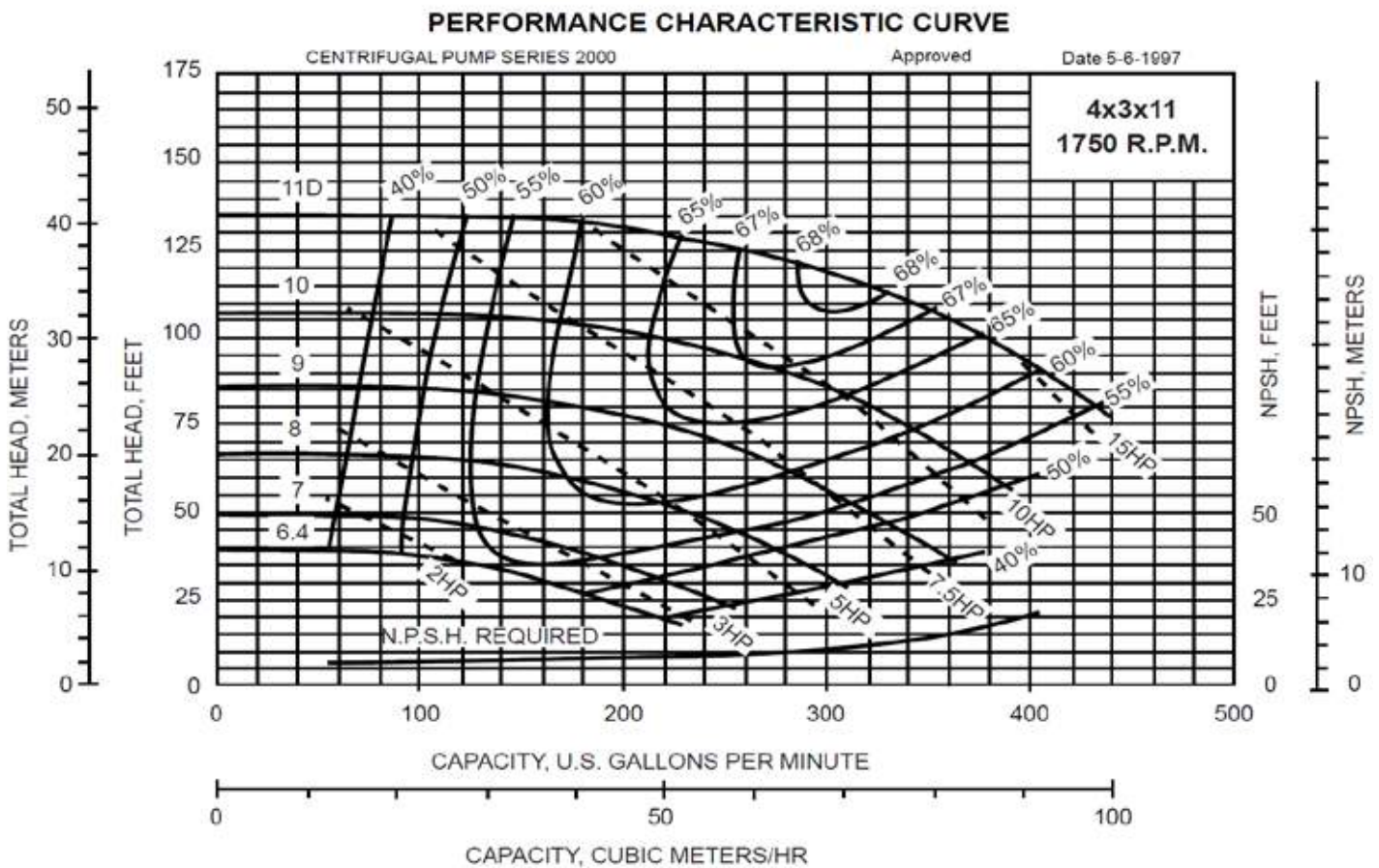
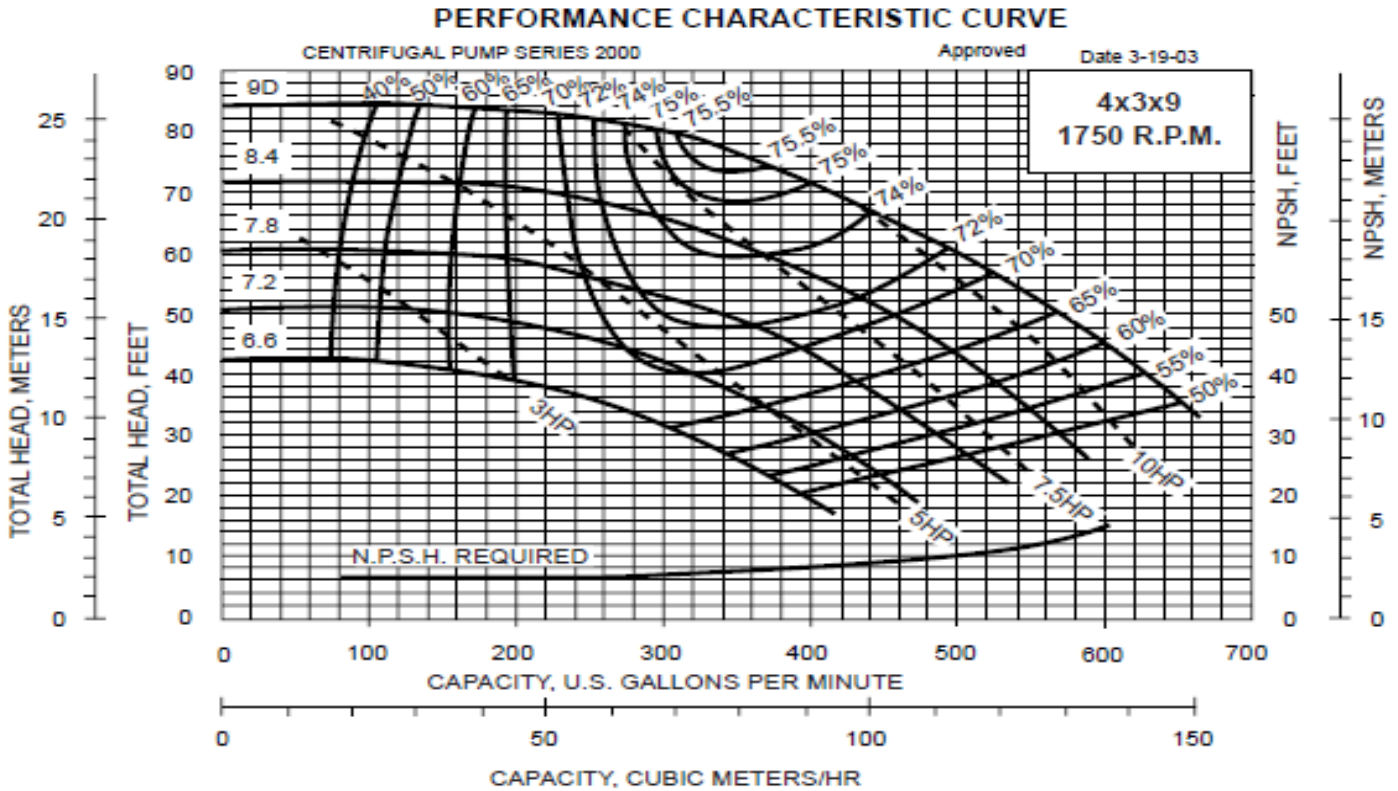

SERIES A-C 2000 - 60 Hz

1750 RPM PUMP CURVES

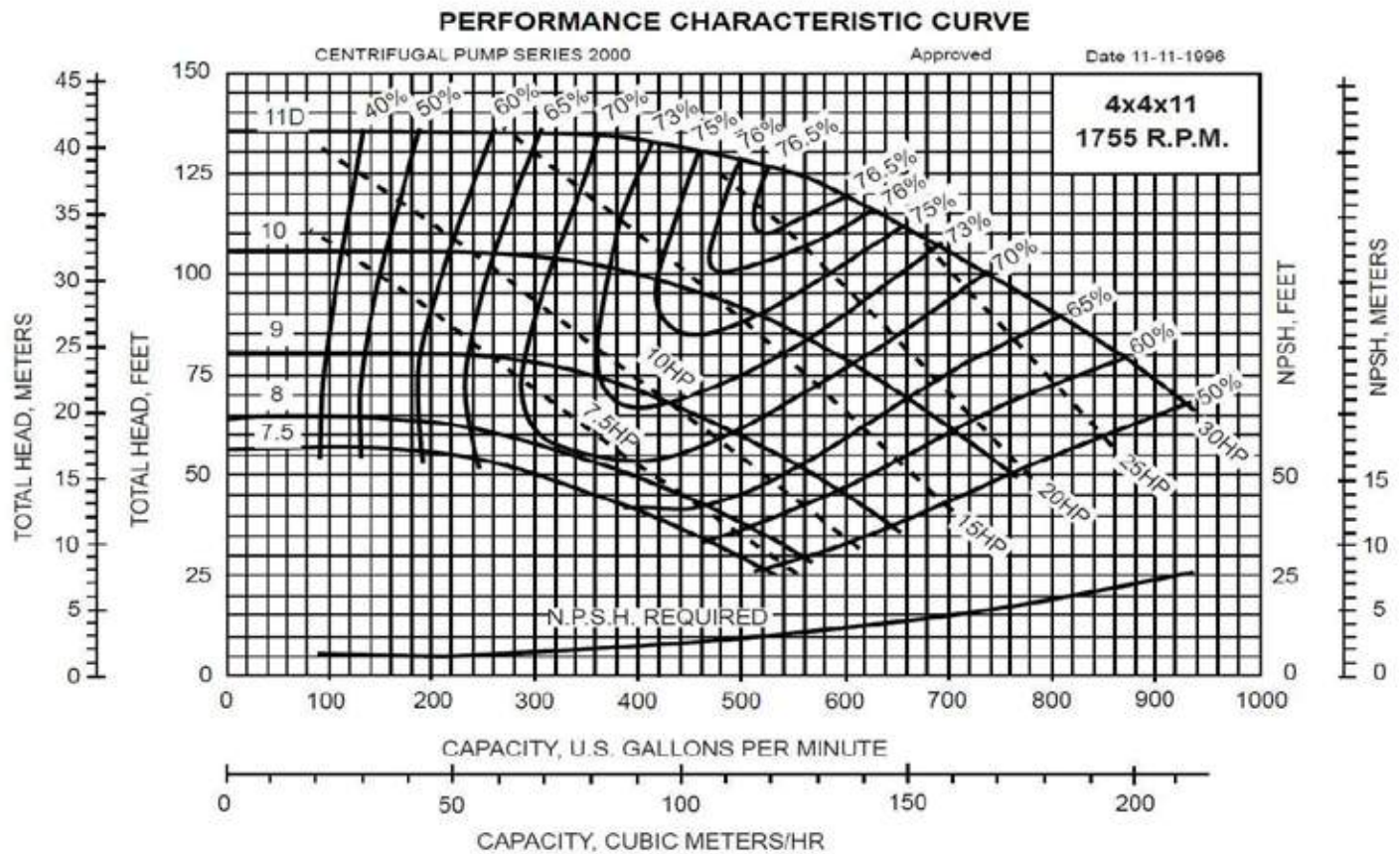
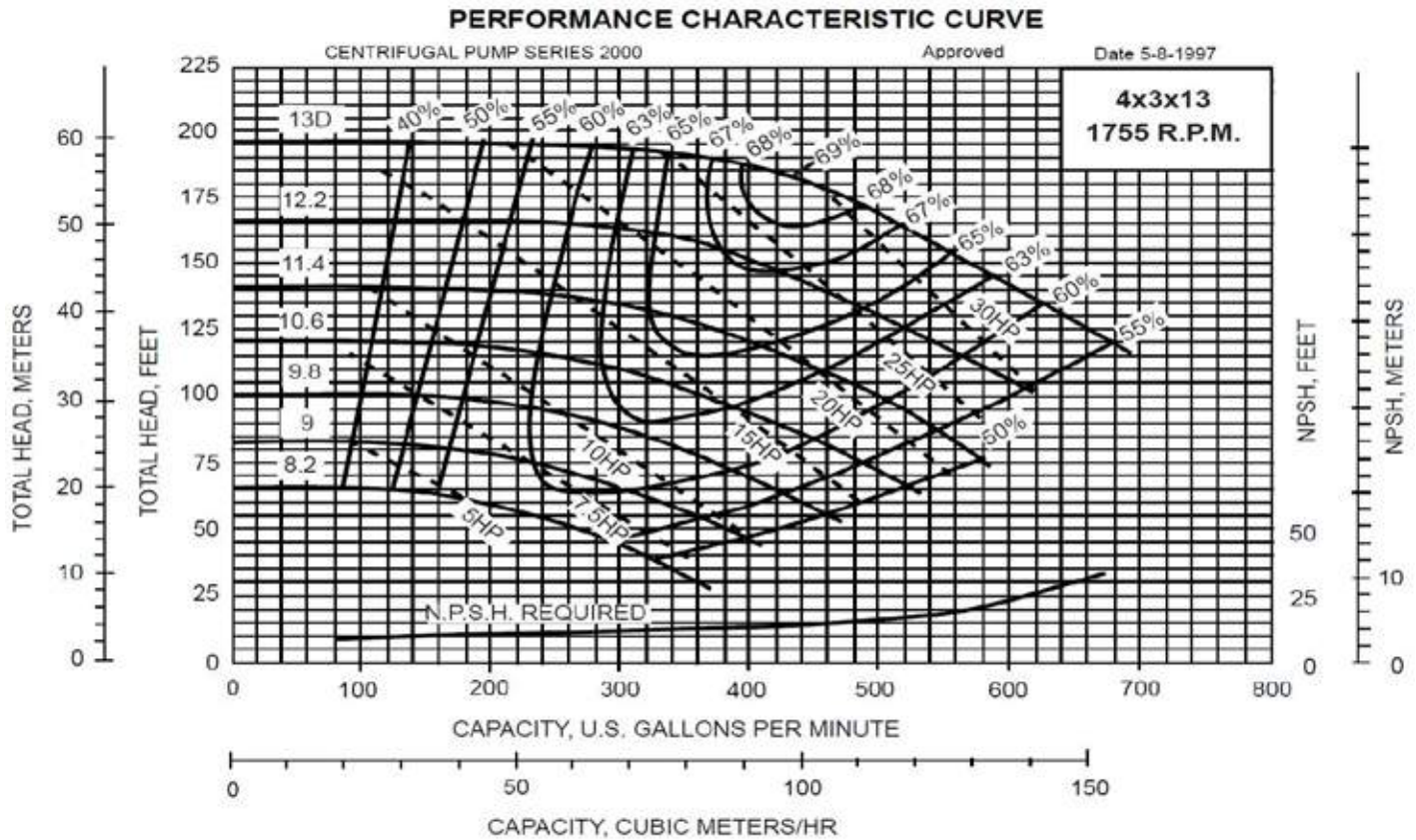

SERIES A-C 2000 - 60 Hz

1750 RPM PUMP CURVES

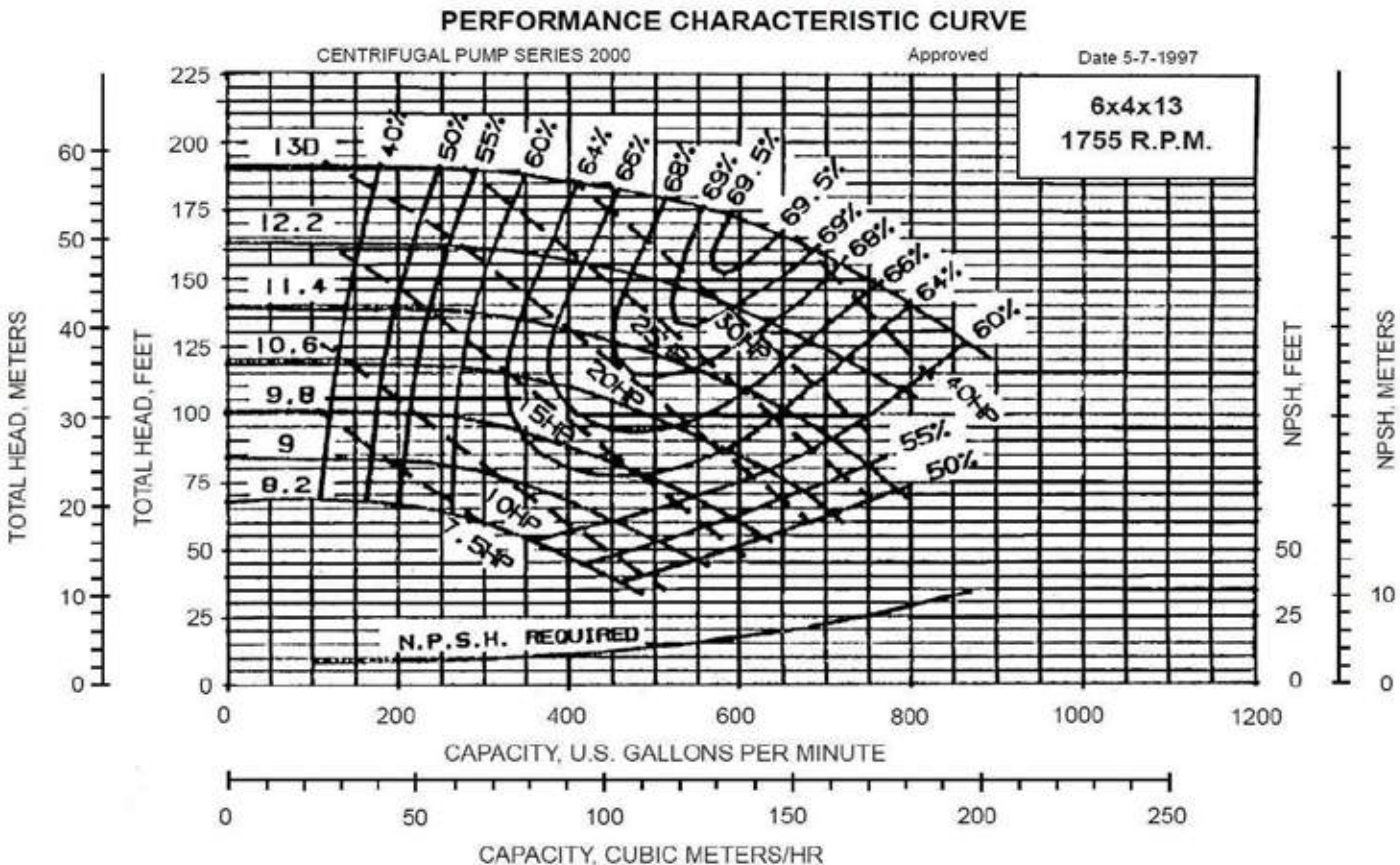
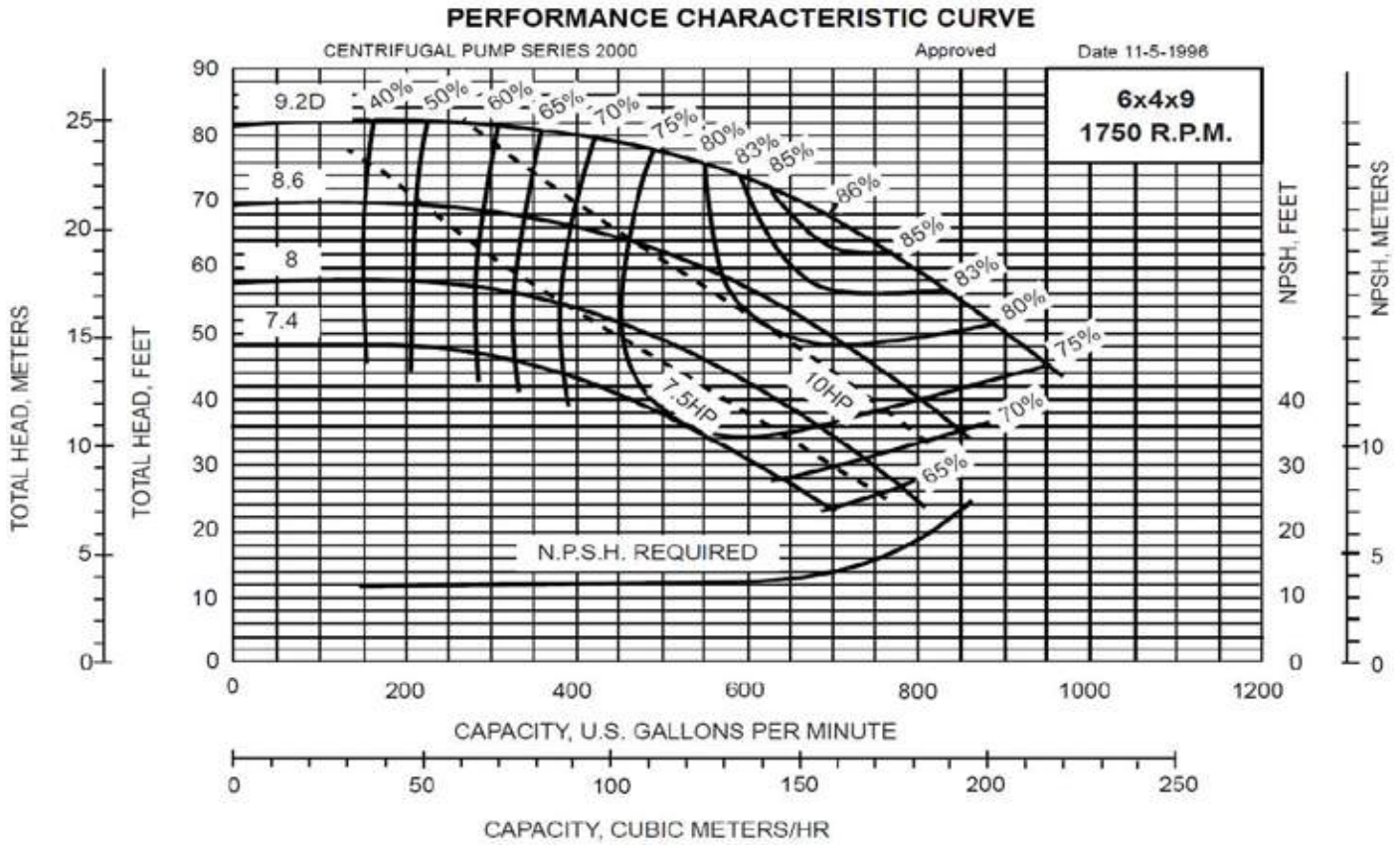

SERIES A-C 2000 - 60 Hz

1750 RPM PUMP CURVES

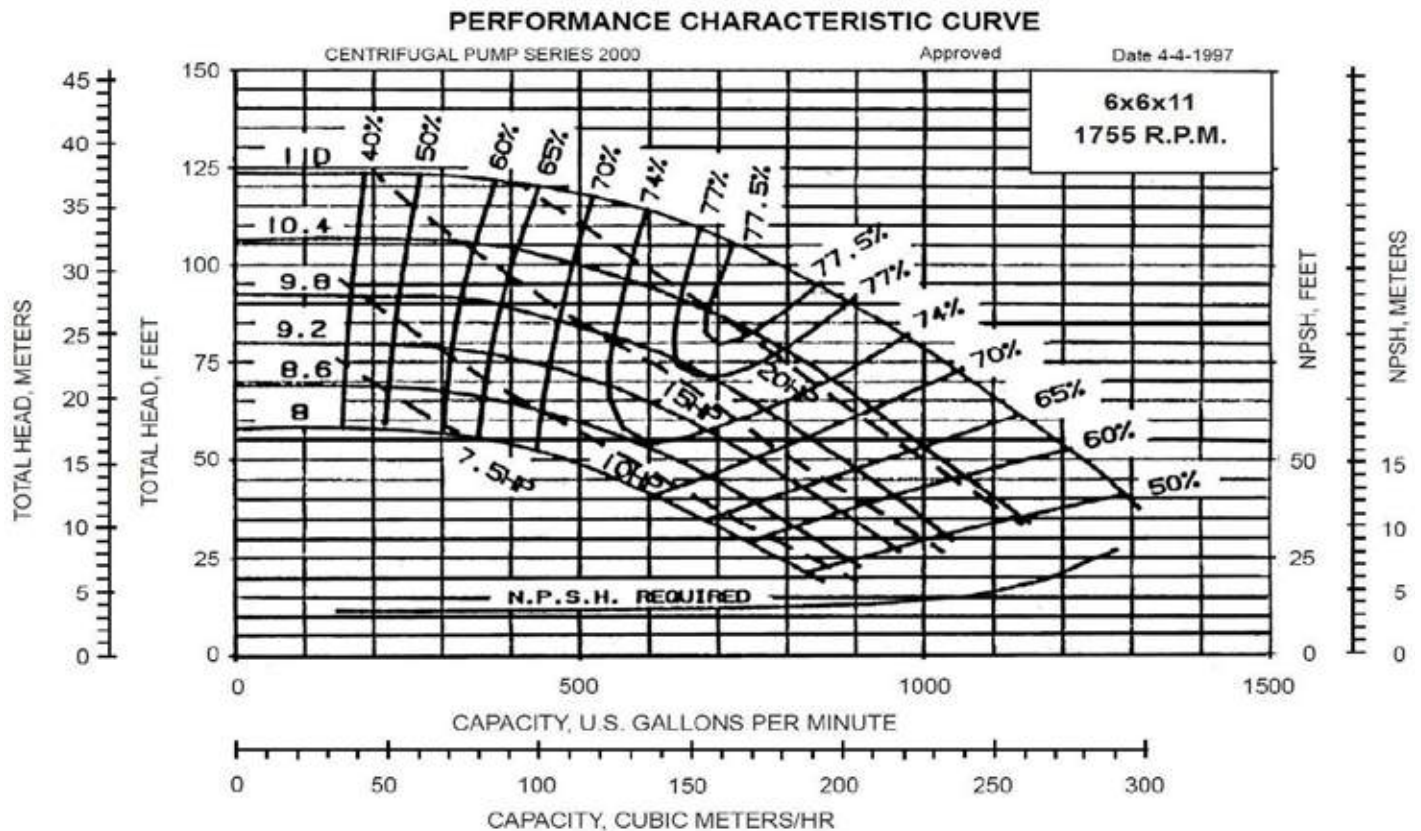
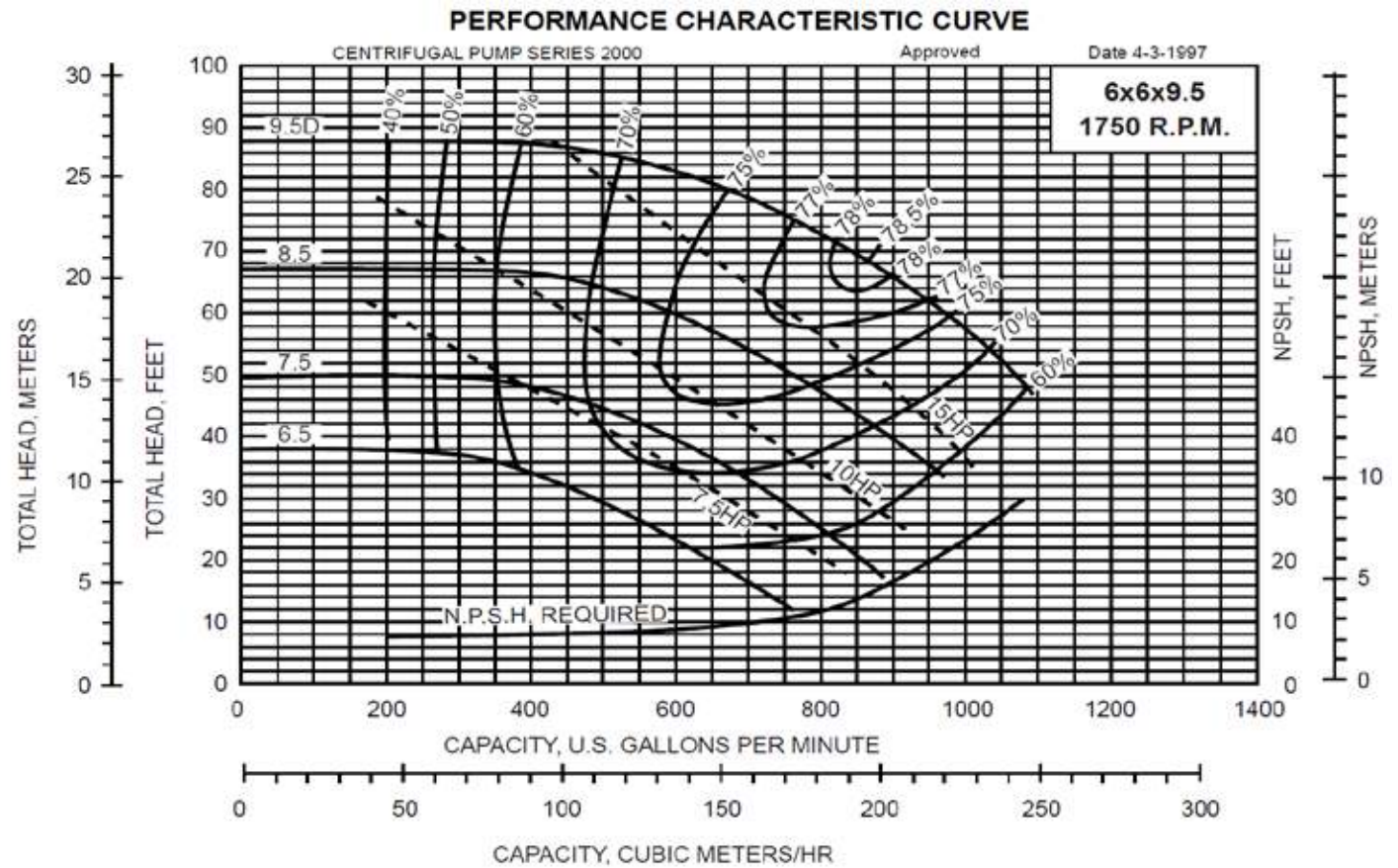

SERIES A-C 2000 - 60 Hz

1750 RPM PUMP CURVES

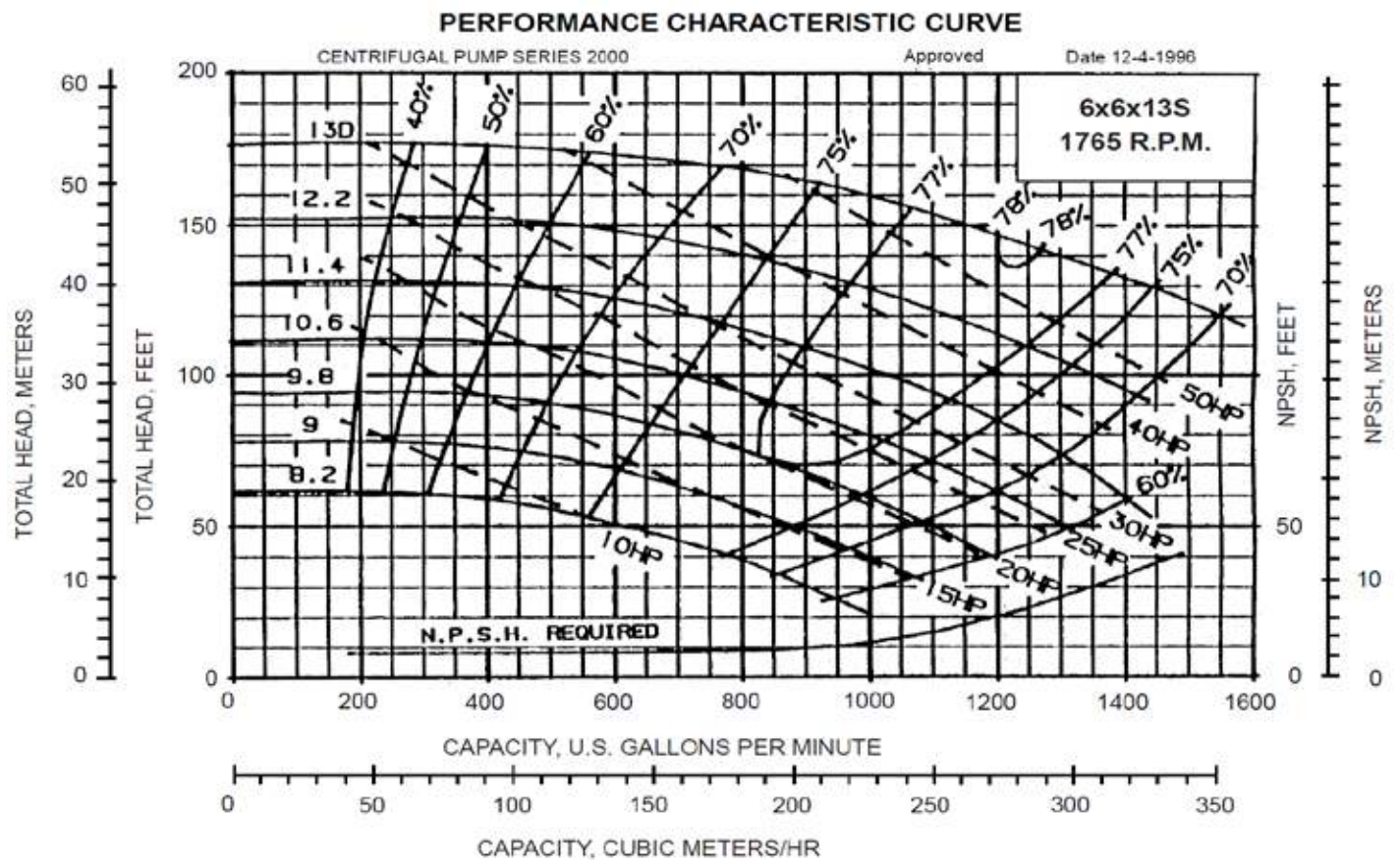
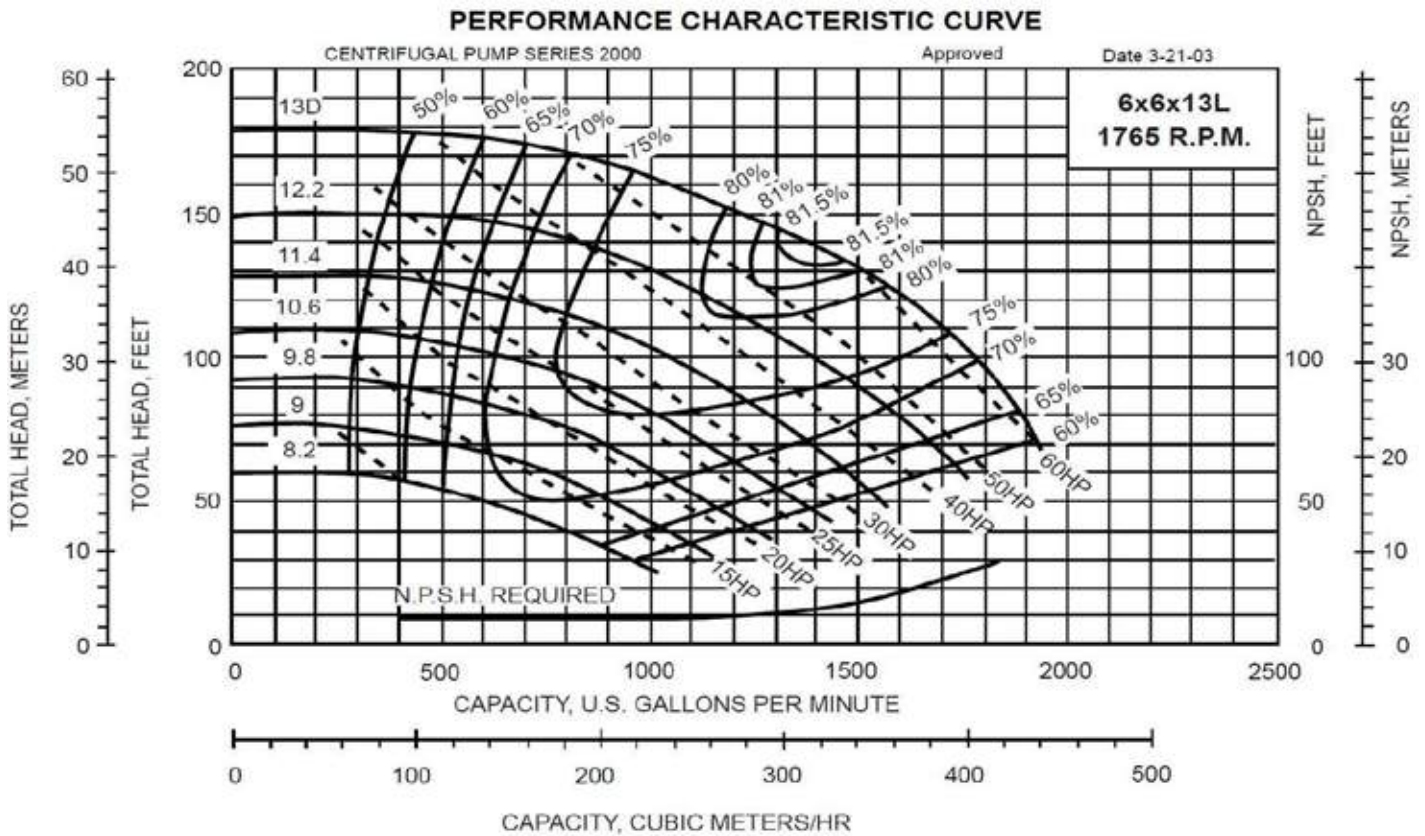

SERIES A-C 2000 - 60 Hz

1750 RPM PUMP CURVES

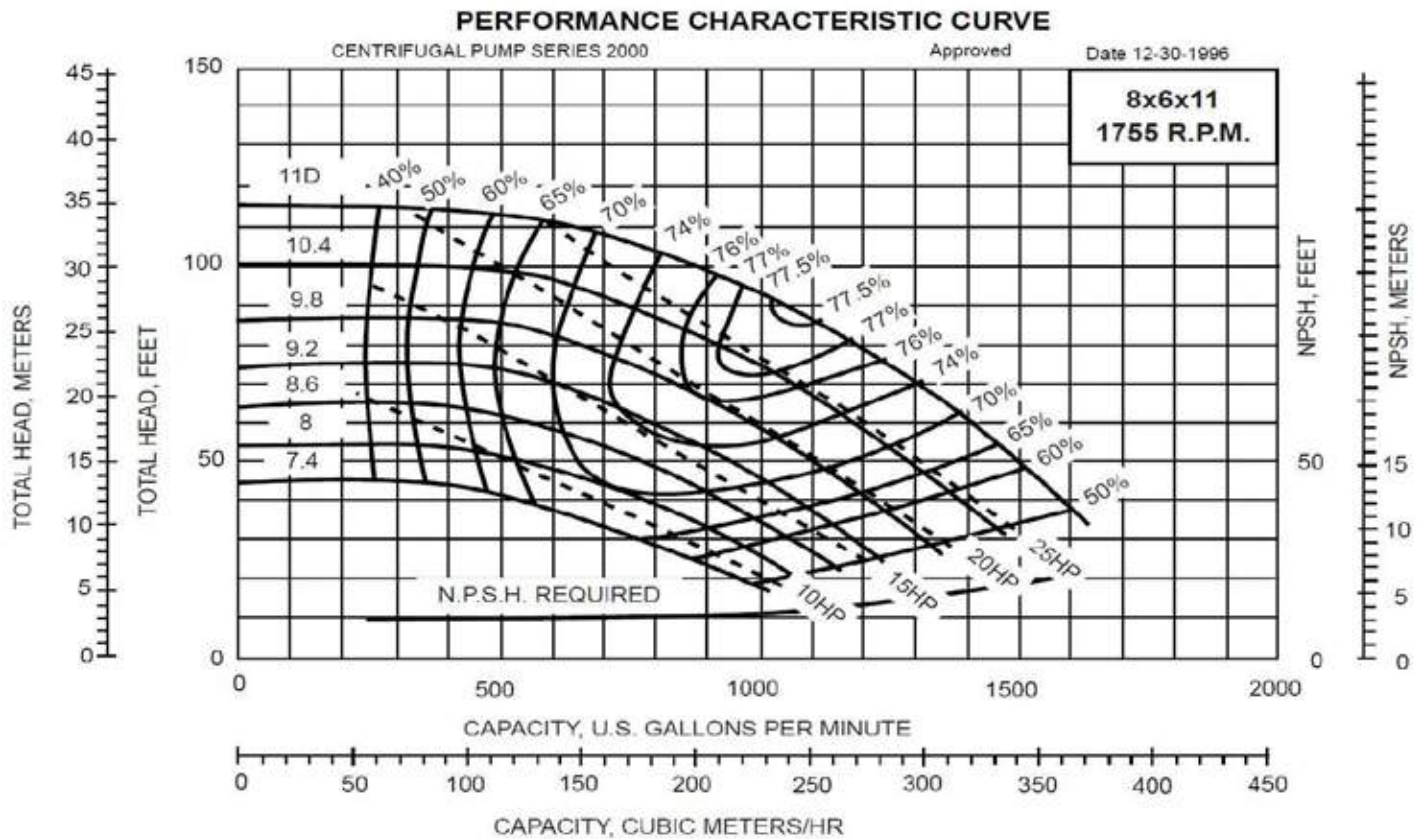
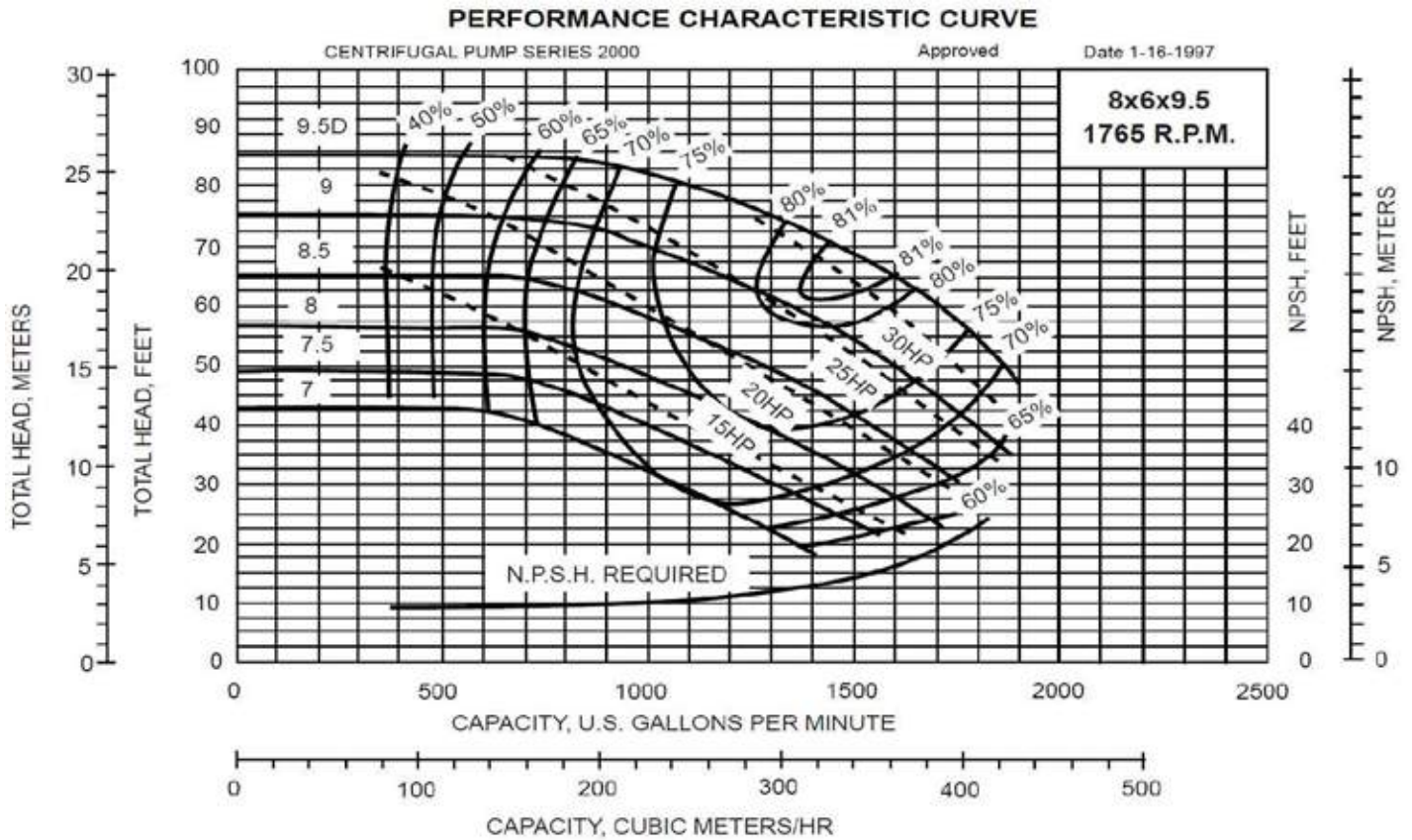

SERIES A-C 2000 - 60 Hz

1750 RPM PUMP CURVES

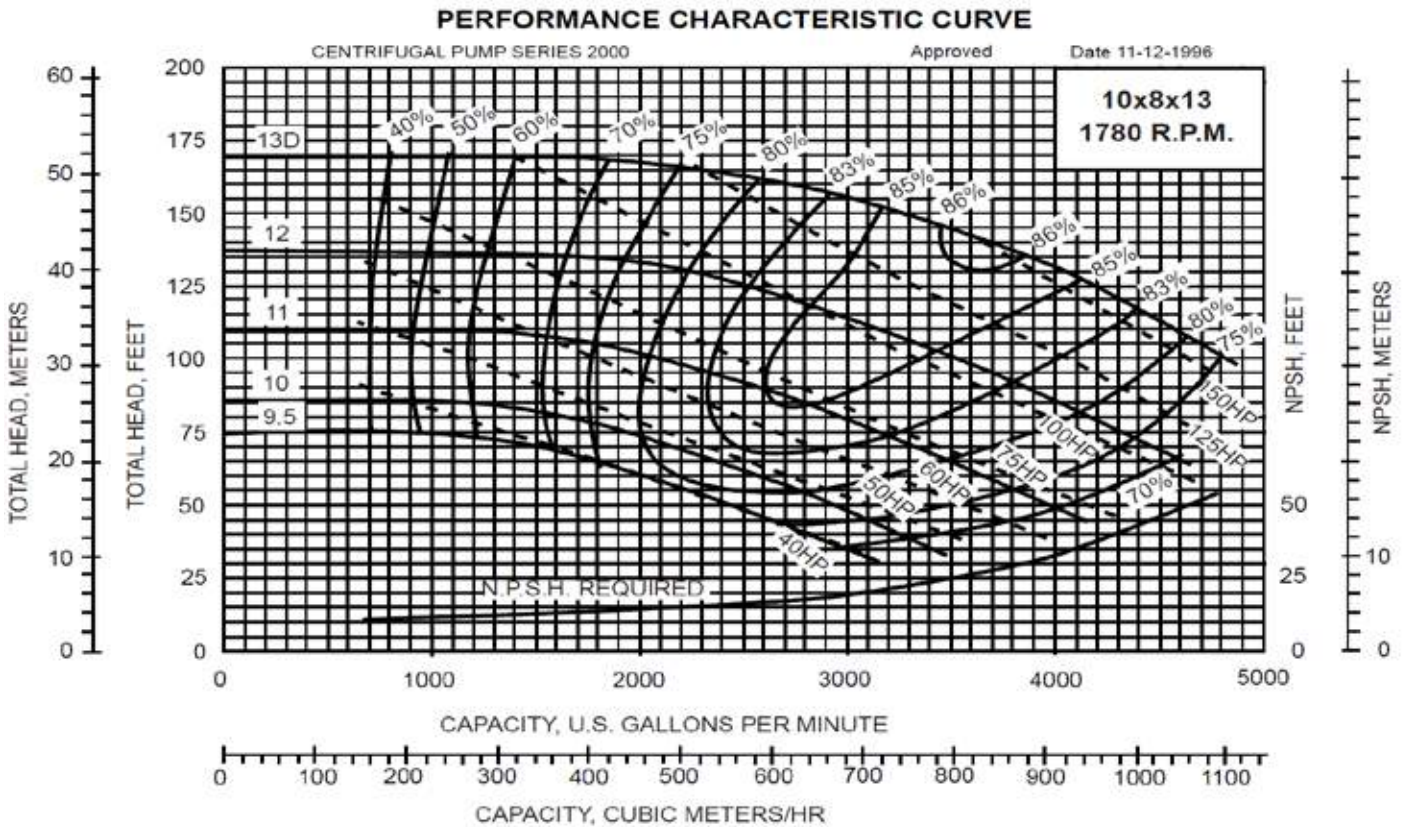
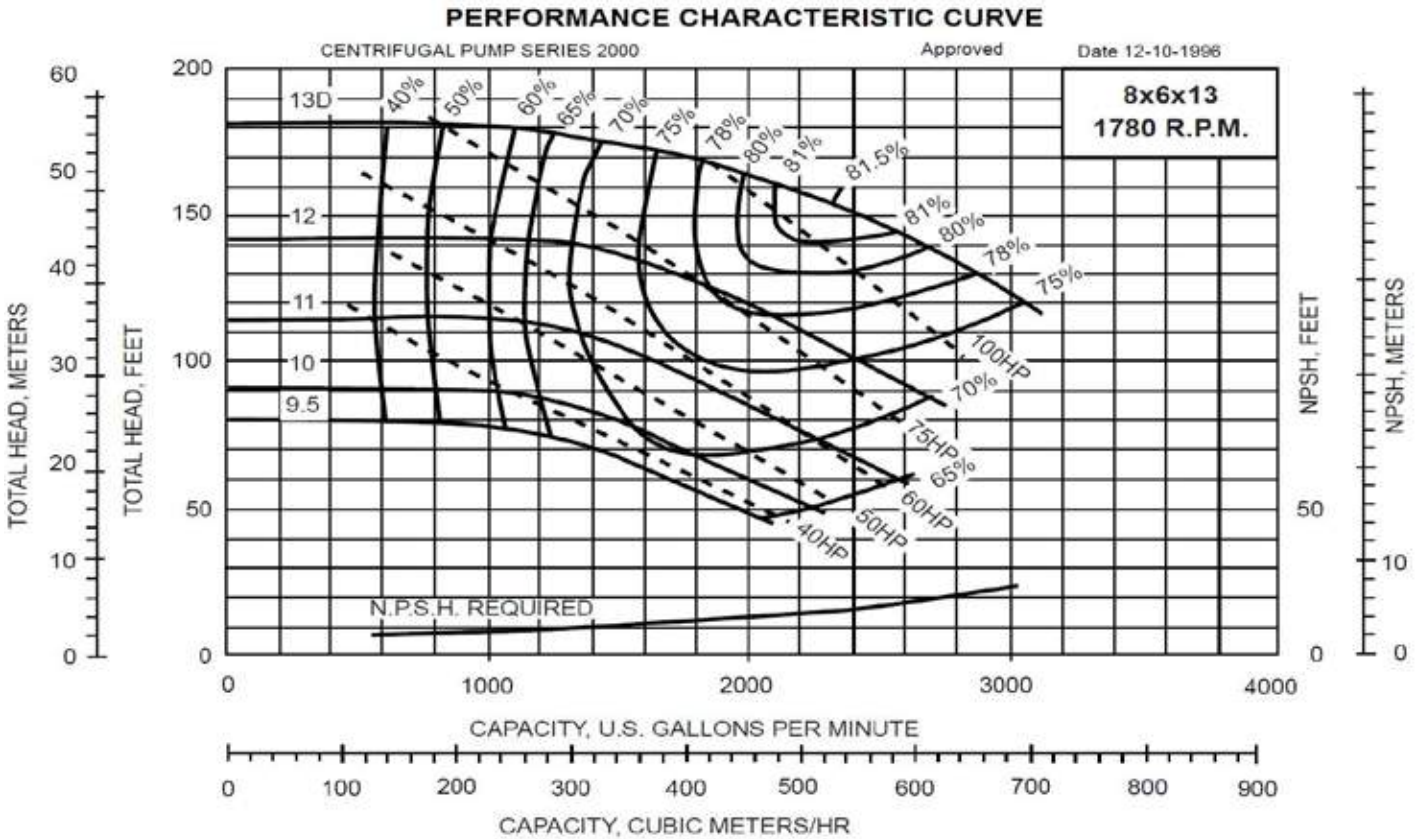

SERIES A-C 2000 - 60 Hz

1150 RPM PUMP CURVES

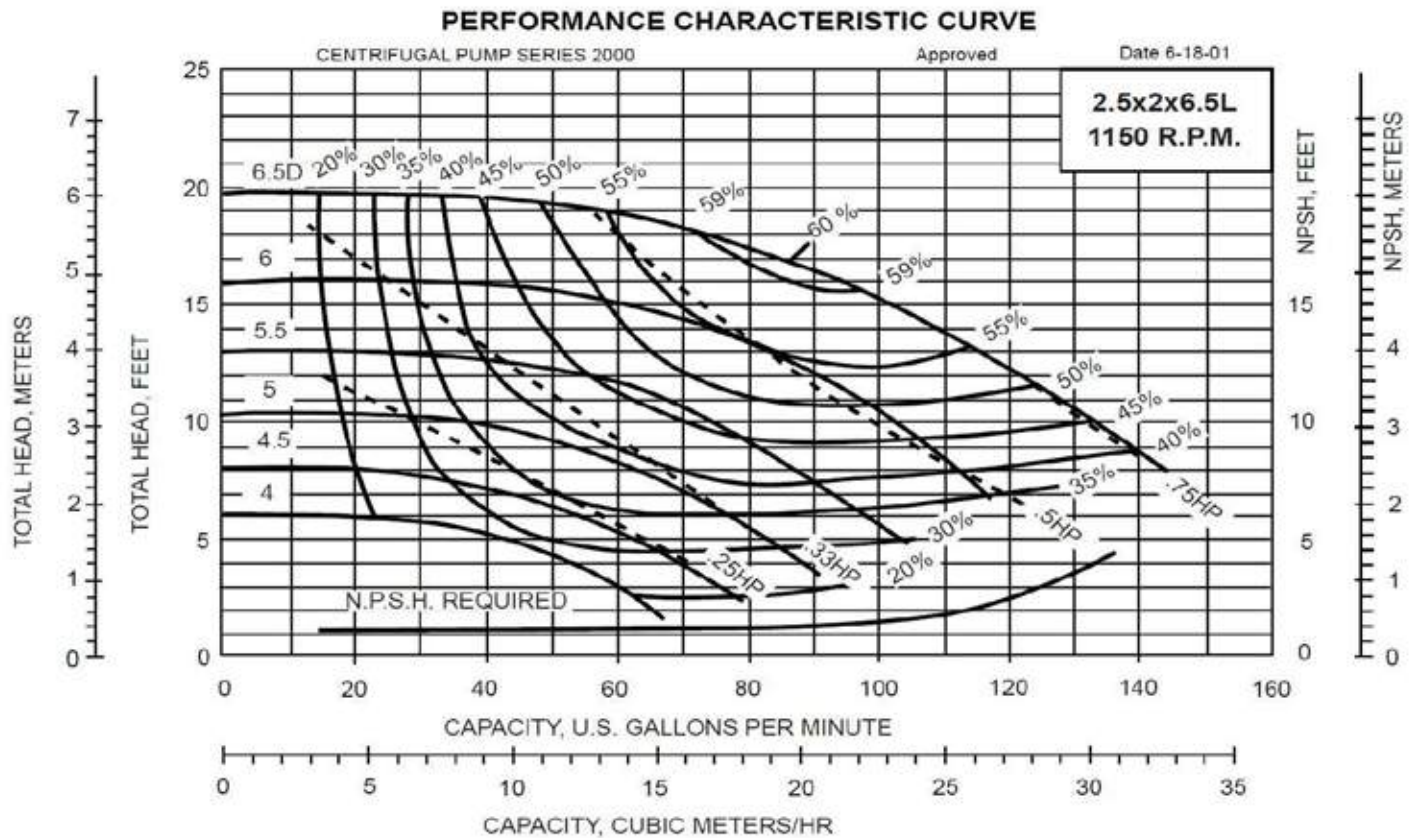
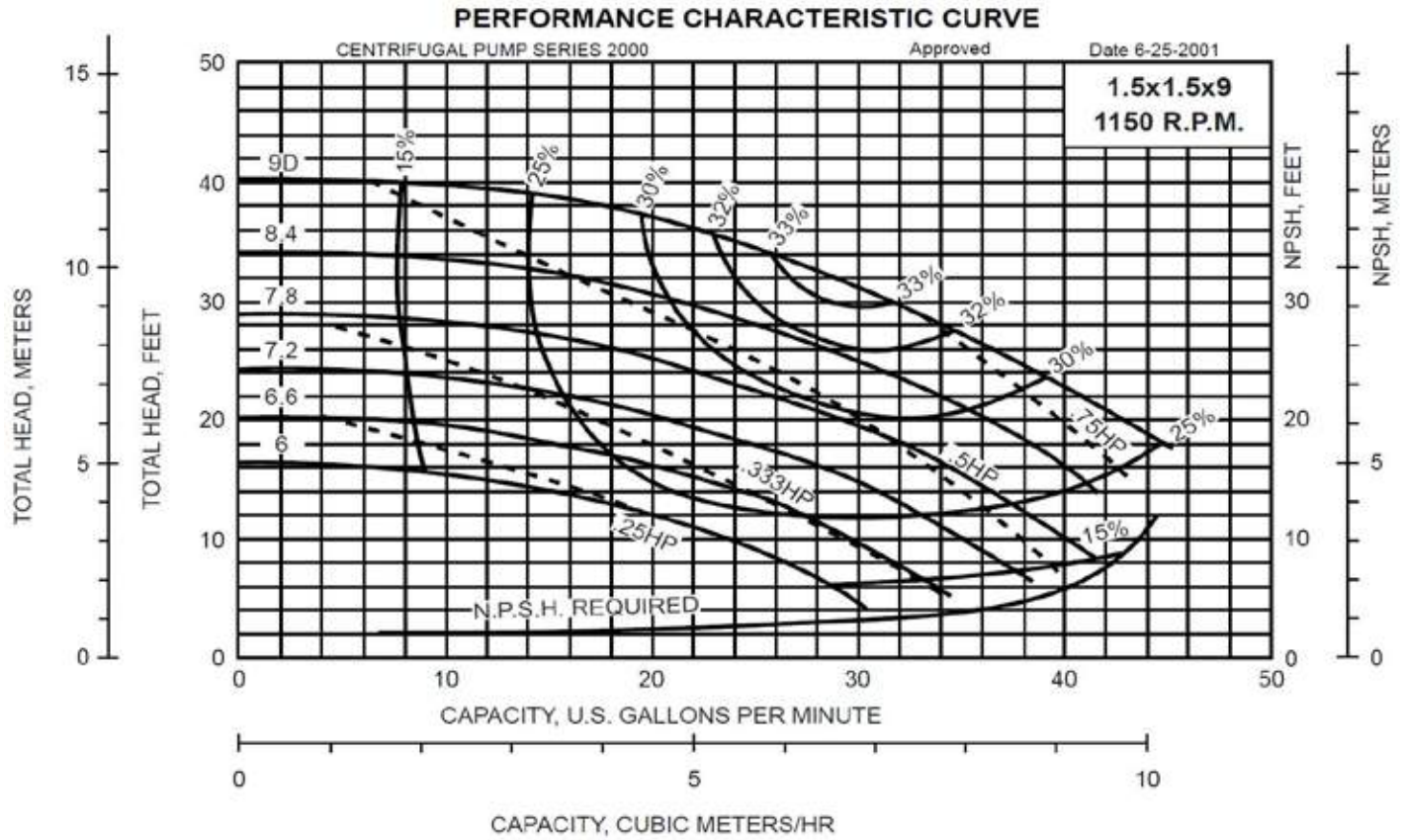

SERIES A-C 2000 - 60 Hz

1150 RPM PUMP CURVES

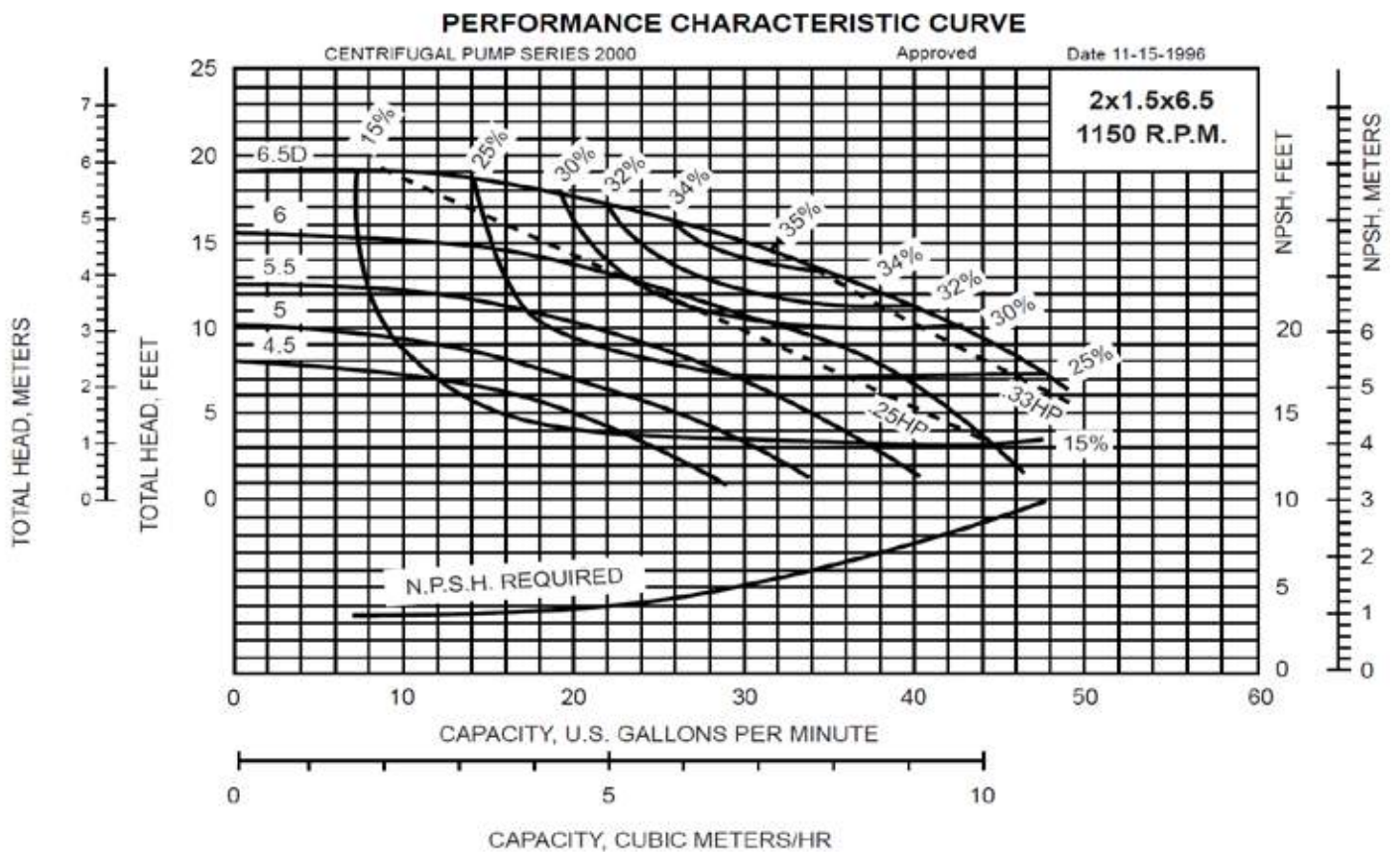
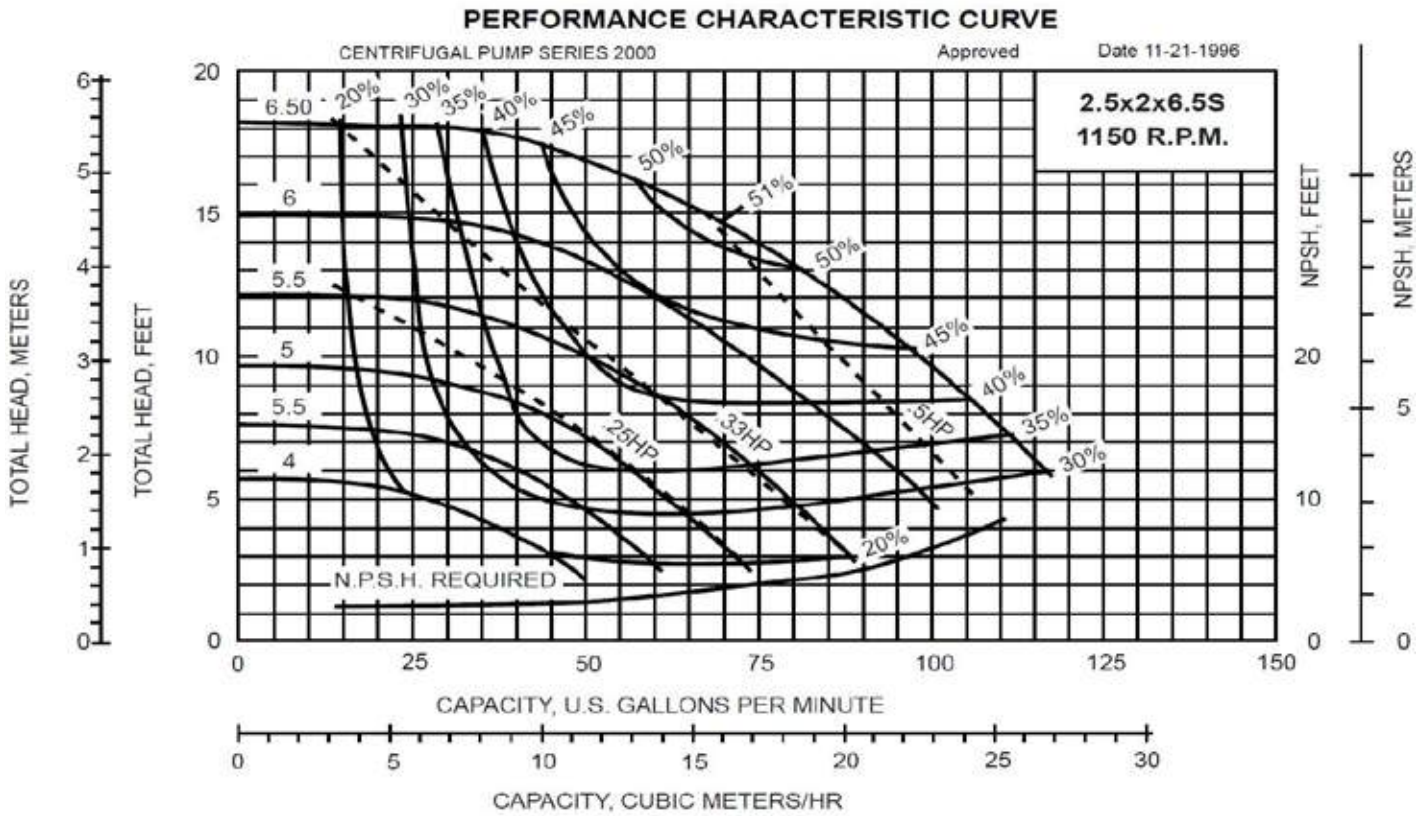

SERIES A-C 2000 - 60 Hz

1150 RPM PUMP CURVES

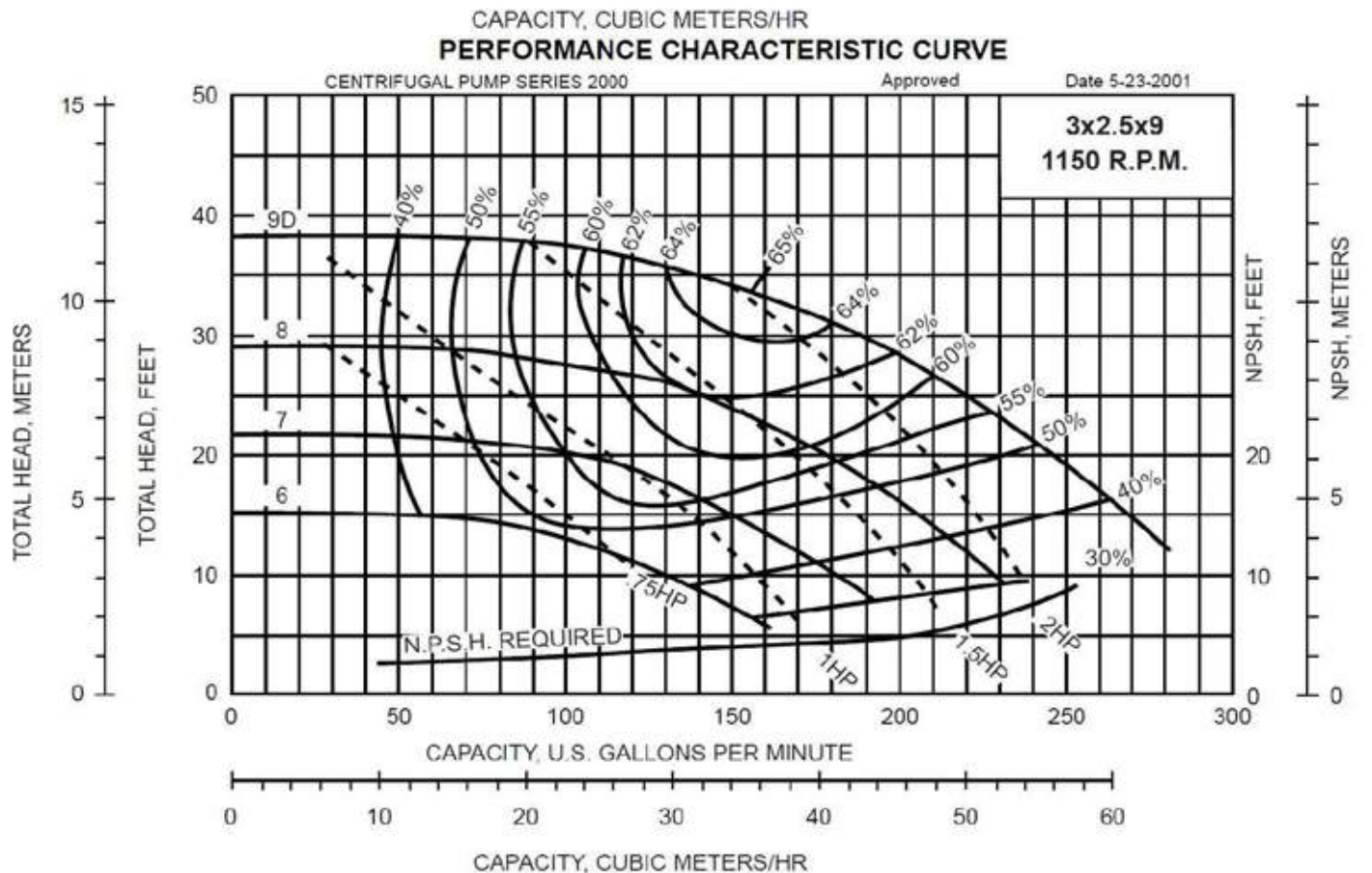
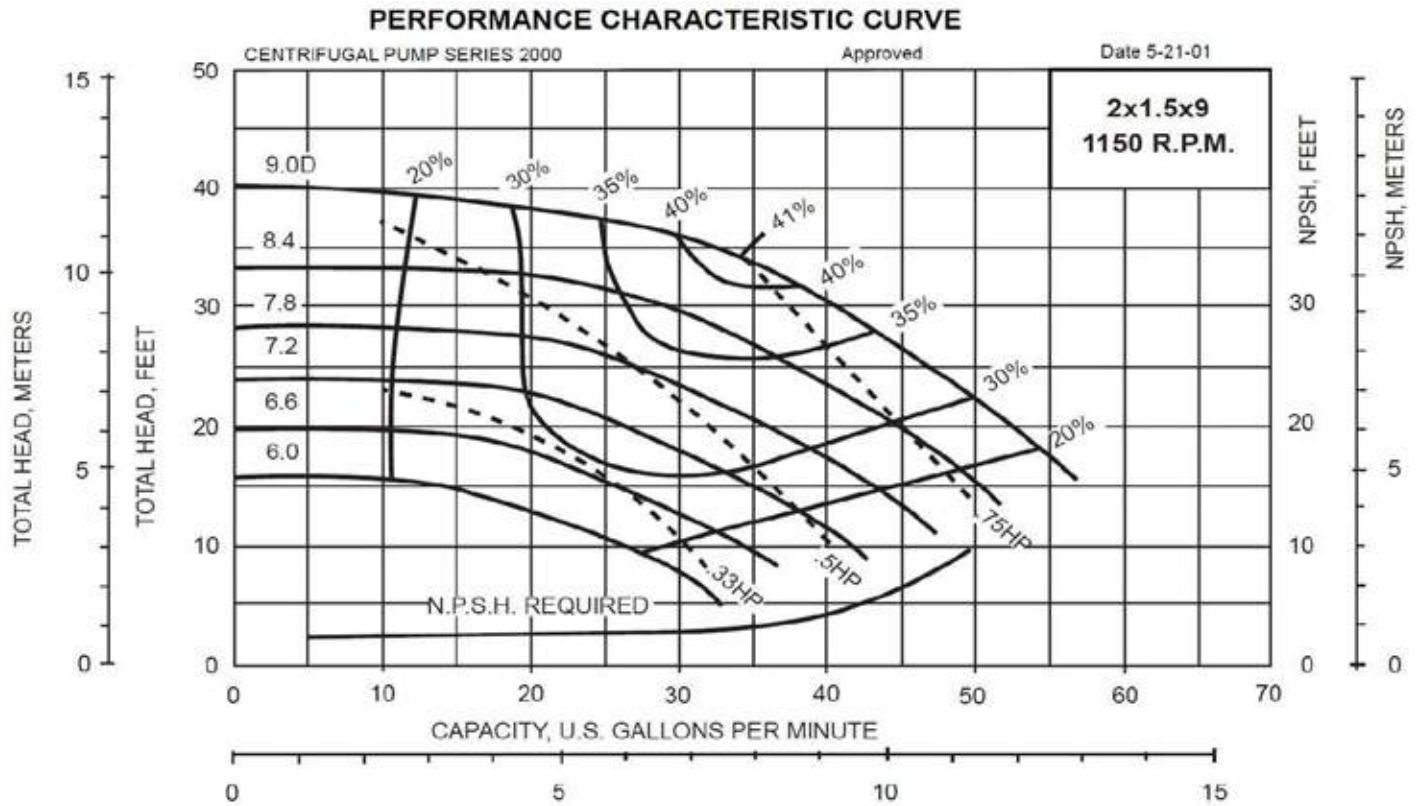

SERIES A-C 2000 - 60 Hz

1150 RPM PUMP CURVES

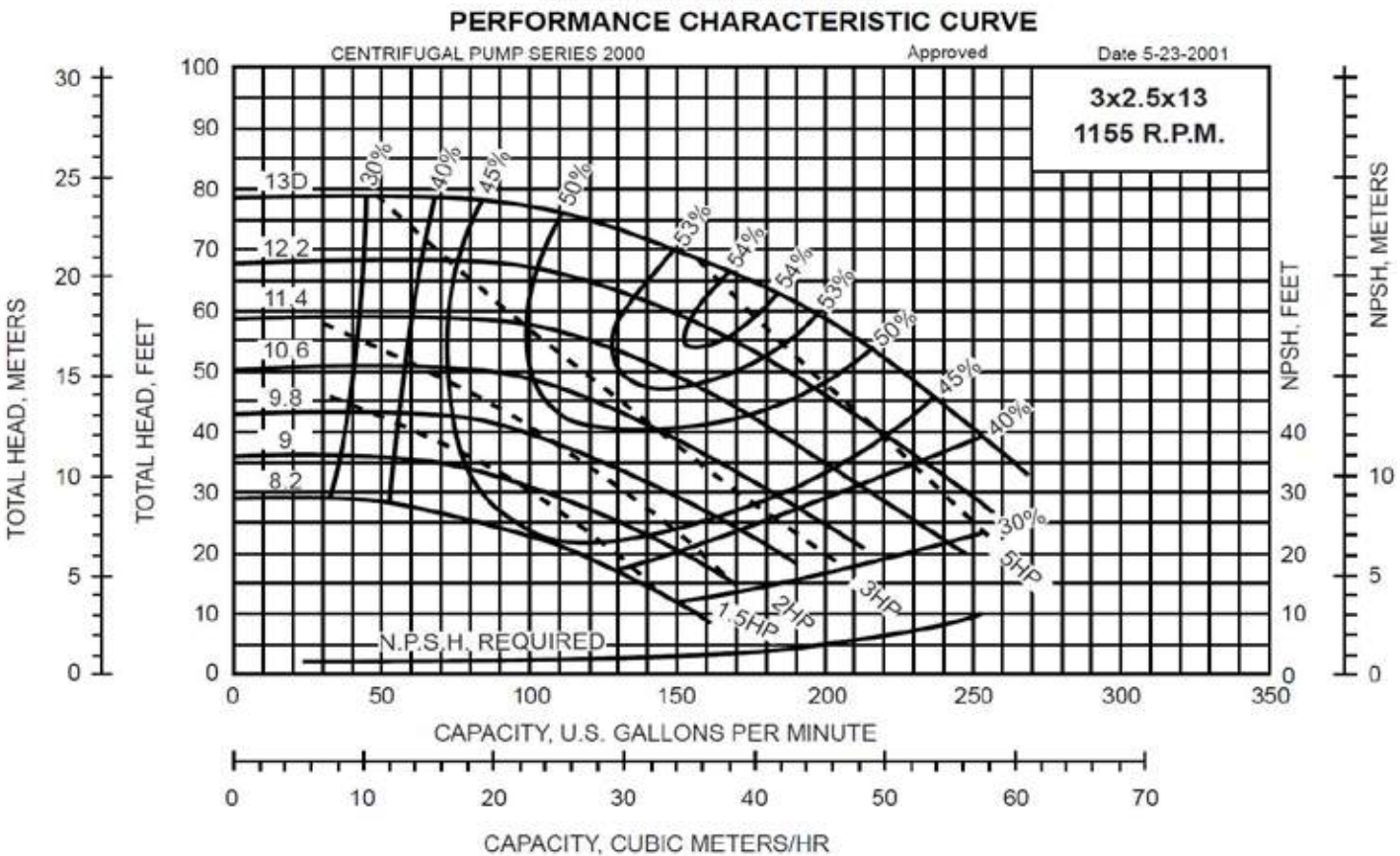
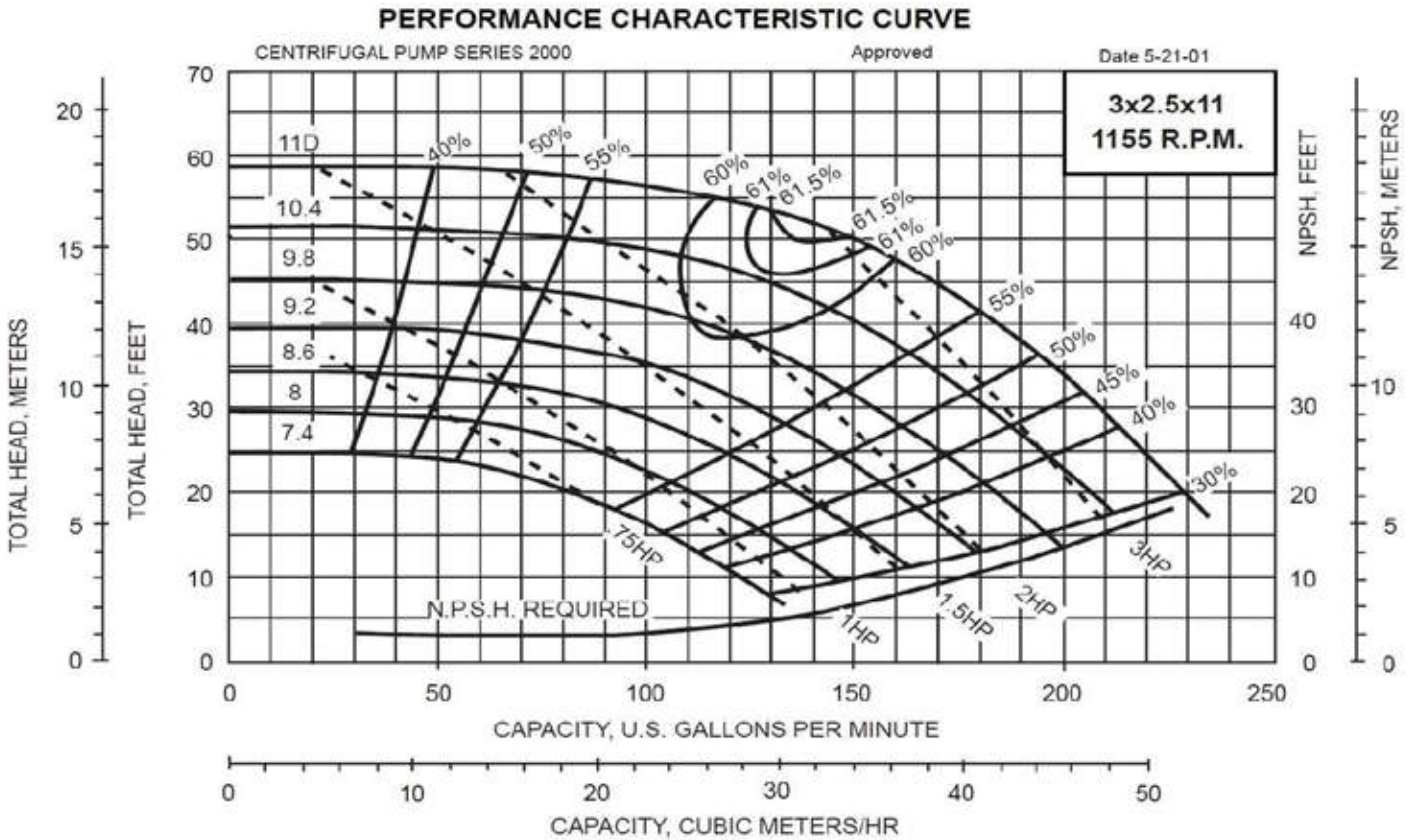

SERIES A-C 2000 - 60 Hz

1150 RPM PUMP CURVES

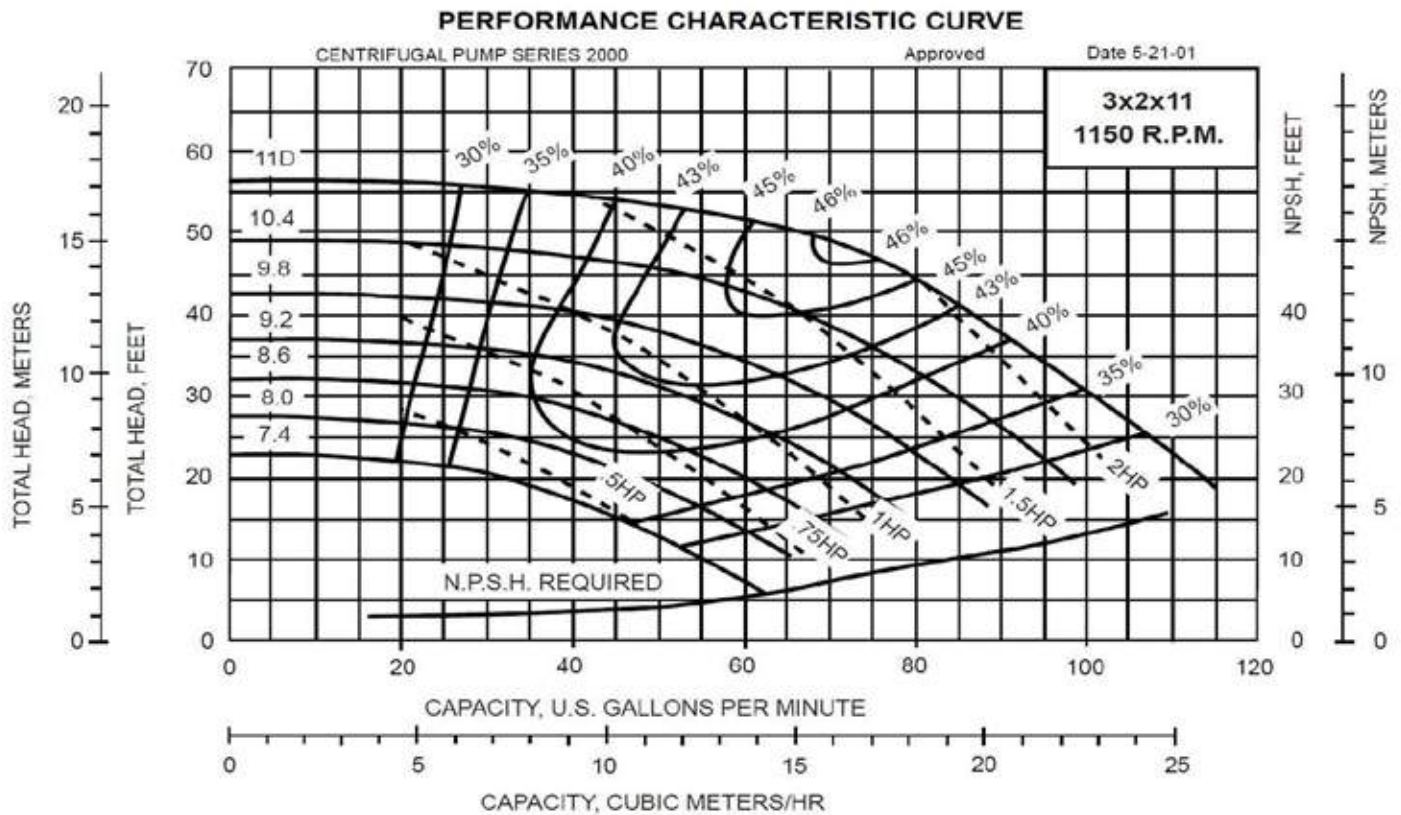
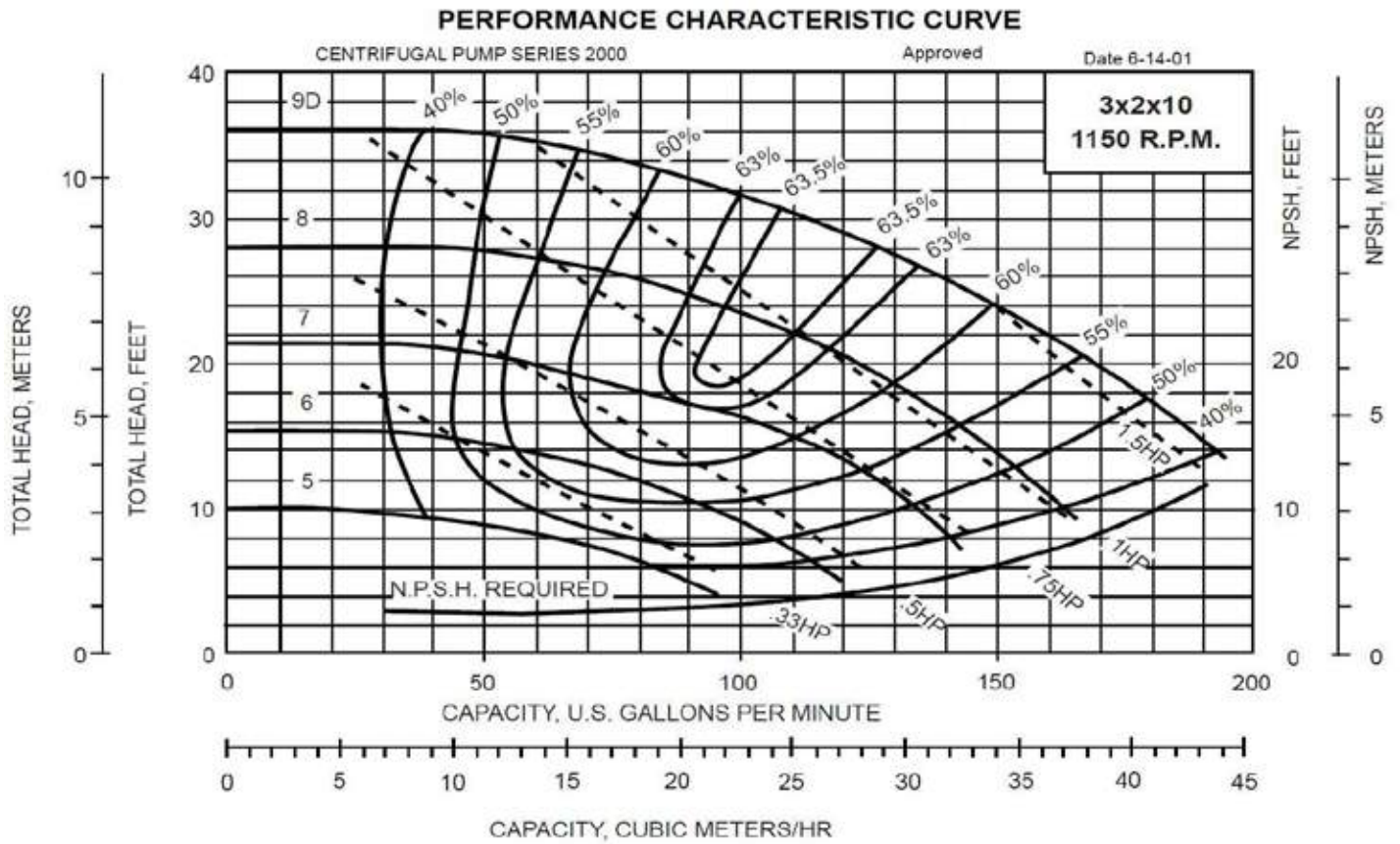

SERIES A-C 2000 - 60 Hz

1150 RPM PUMP CURVES

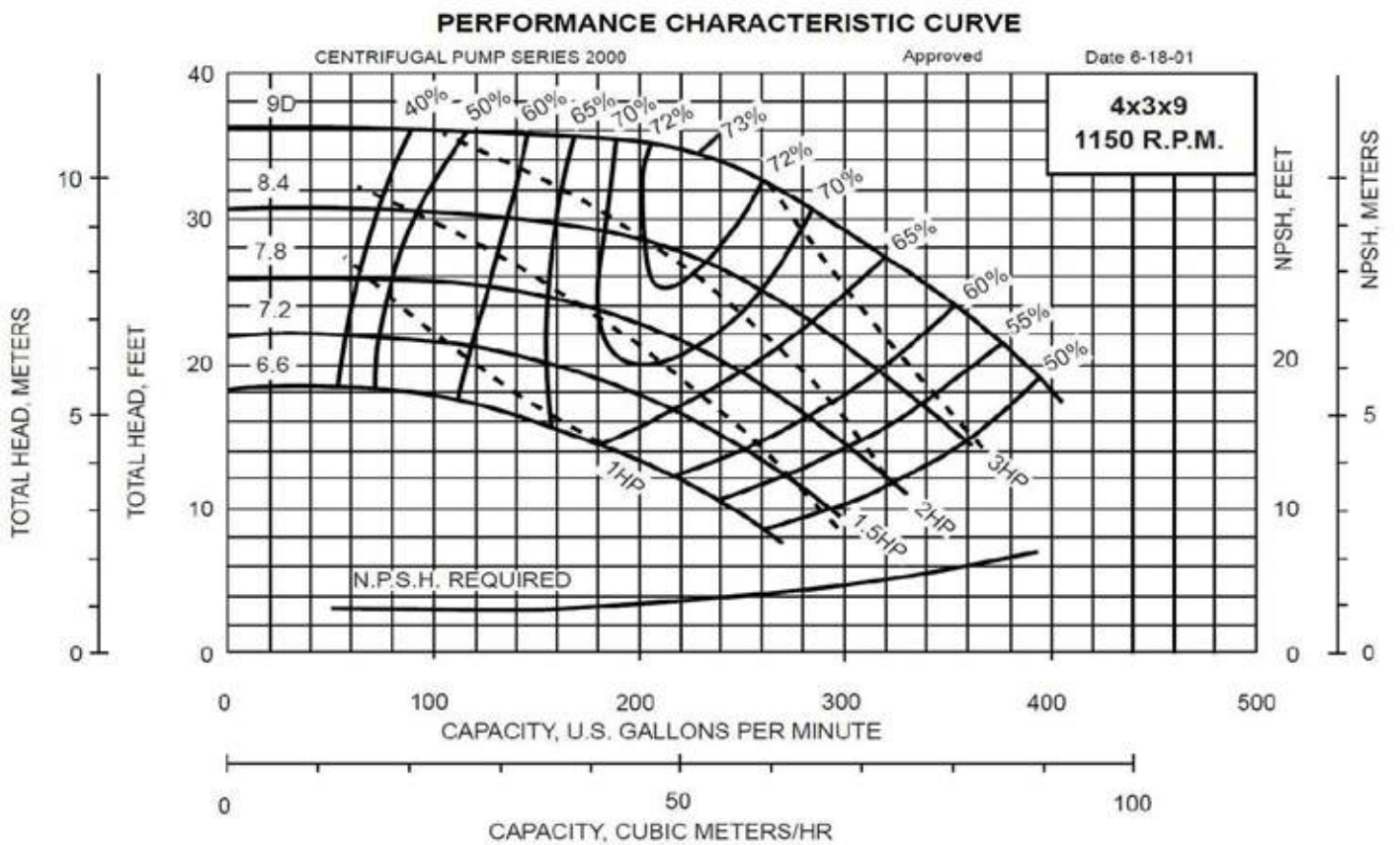
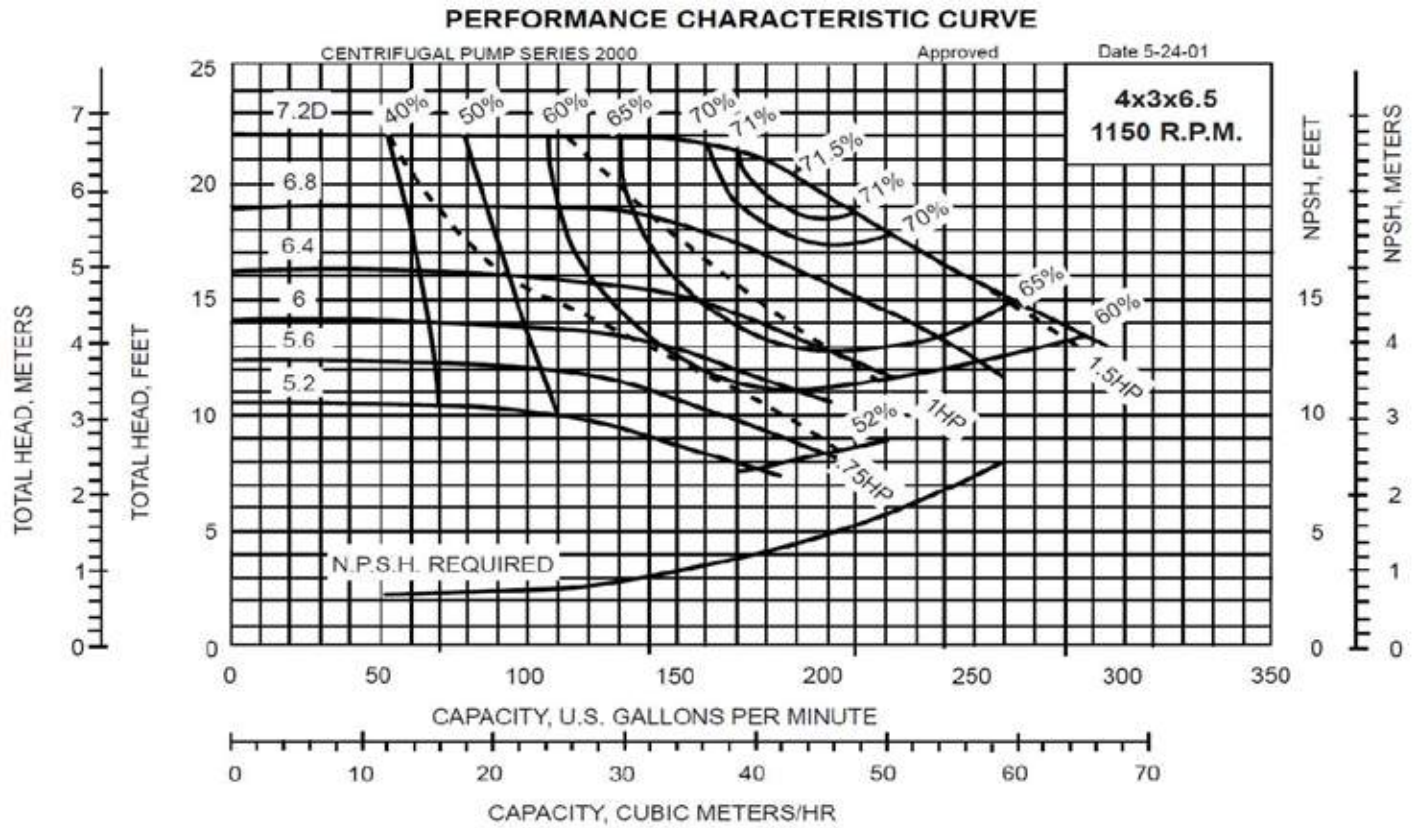

SERIES A-C 2000 - 60 Hz

1150 RPM PUMP CURVES

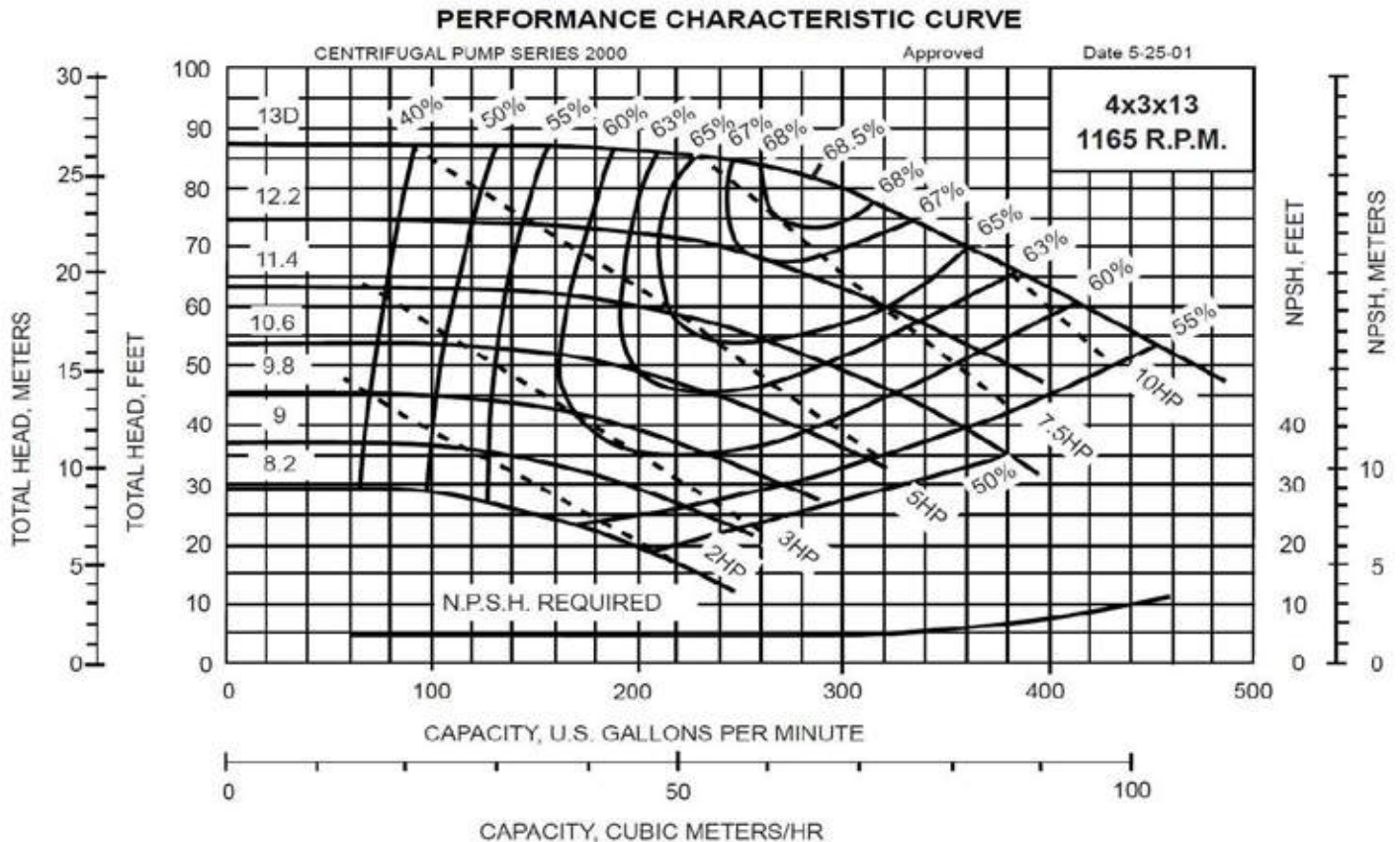
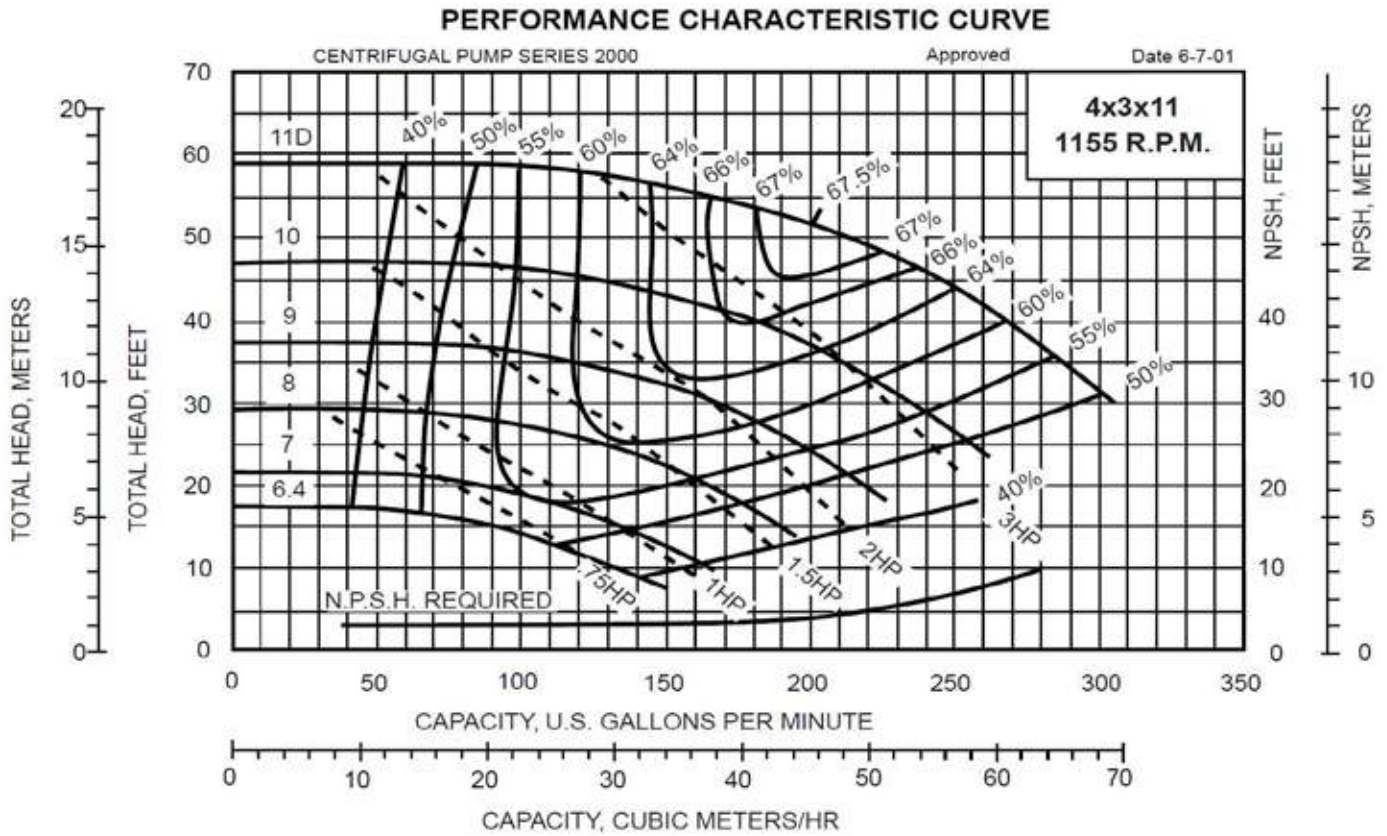

SERIES A-C 2000 - 60 Hz

1150 RPM PUMP CURVES

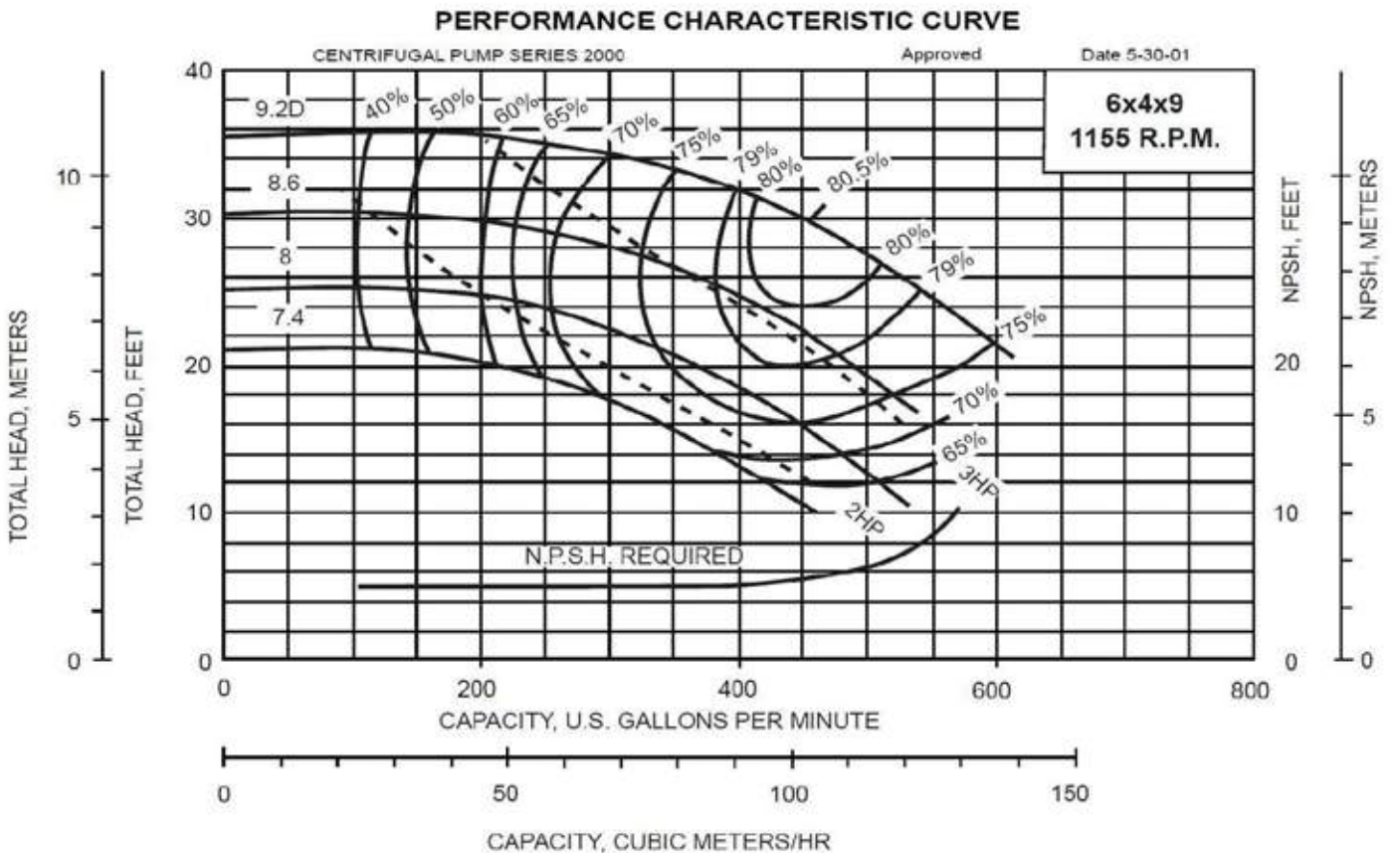
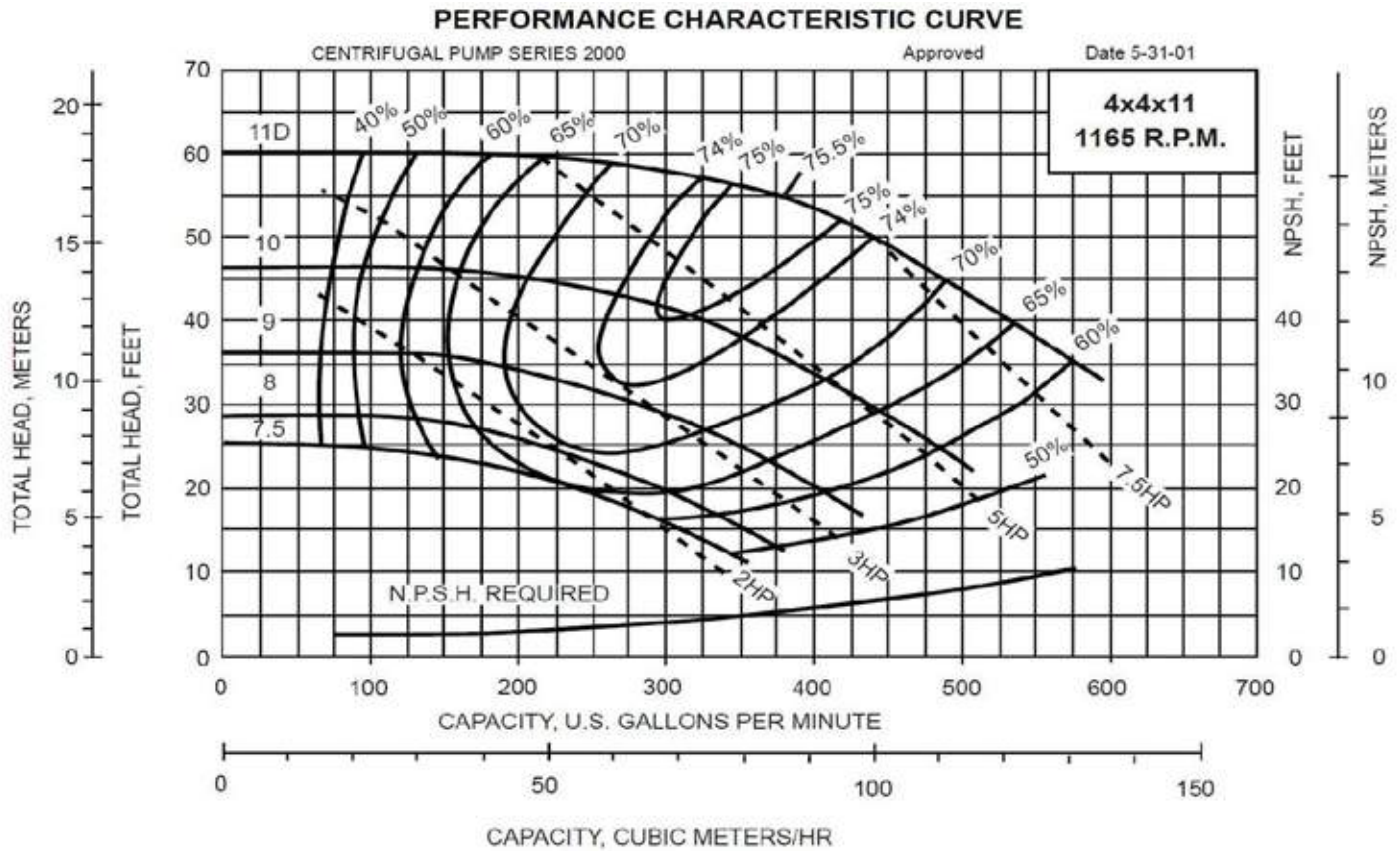

SERIES A-C 2000 - 60 Hz

1150 RPM PUMP CURVES

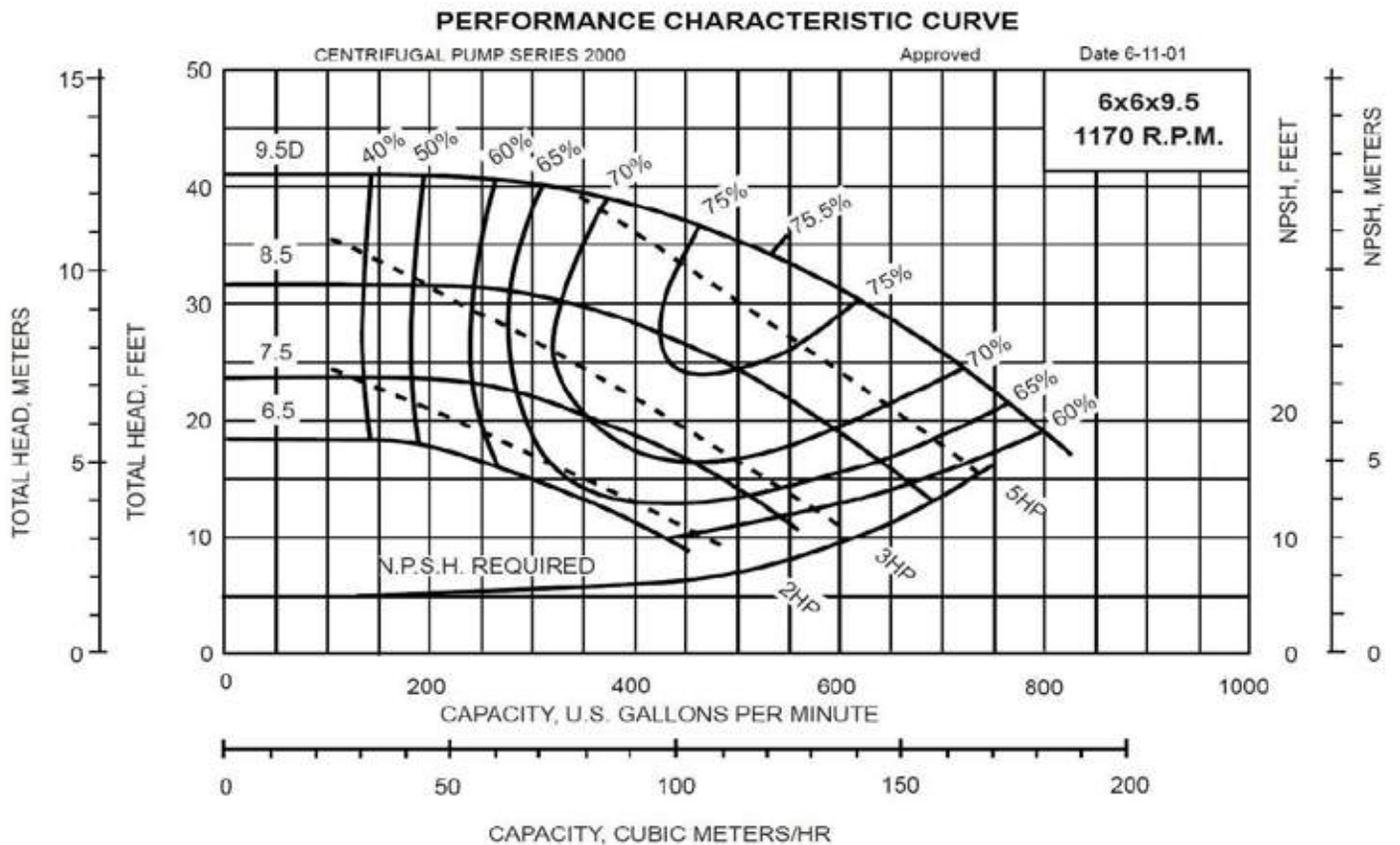
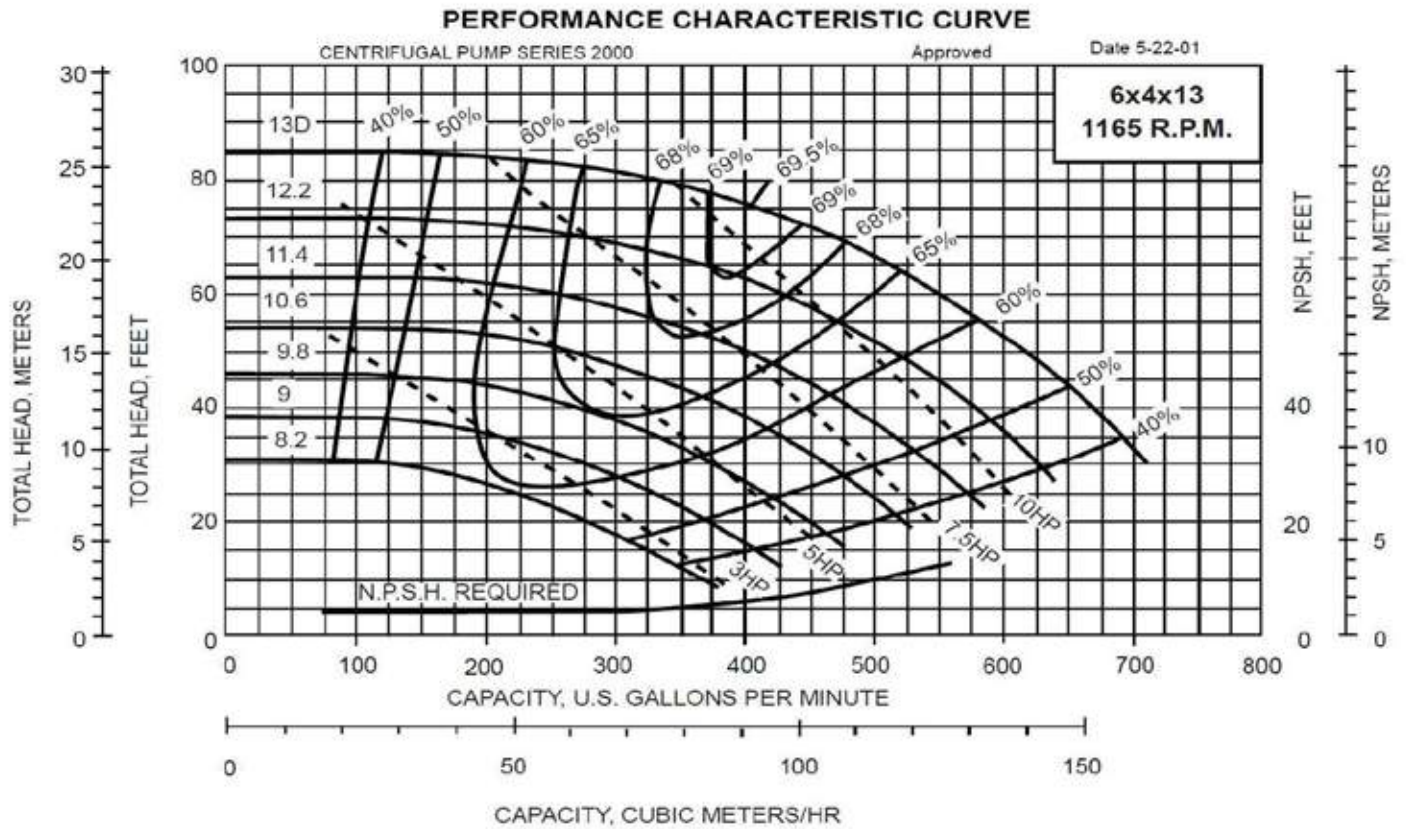

SERIES A-C 2000 - 60 Hz

1150 RPM PUMP CURVES

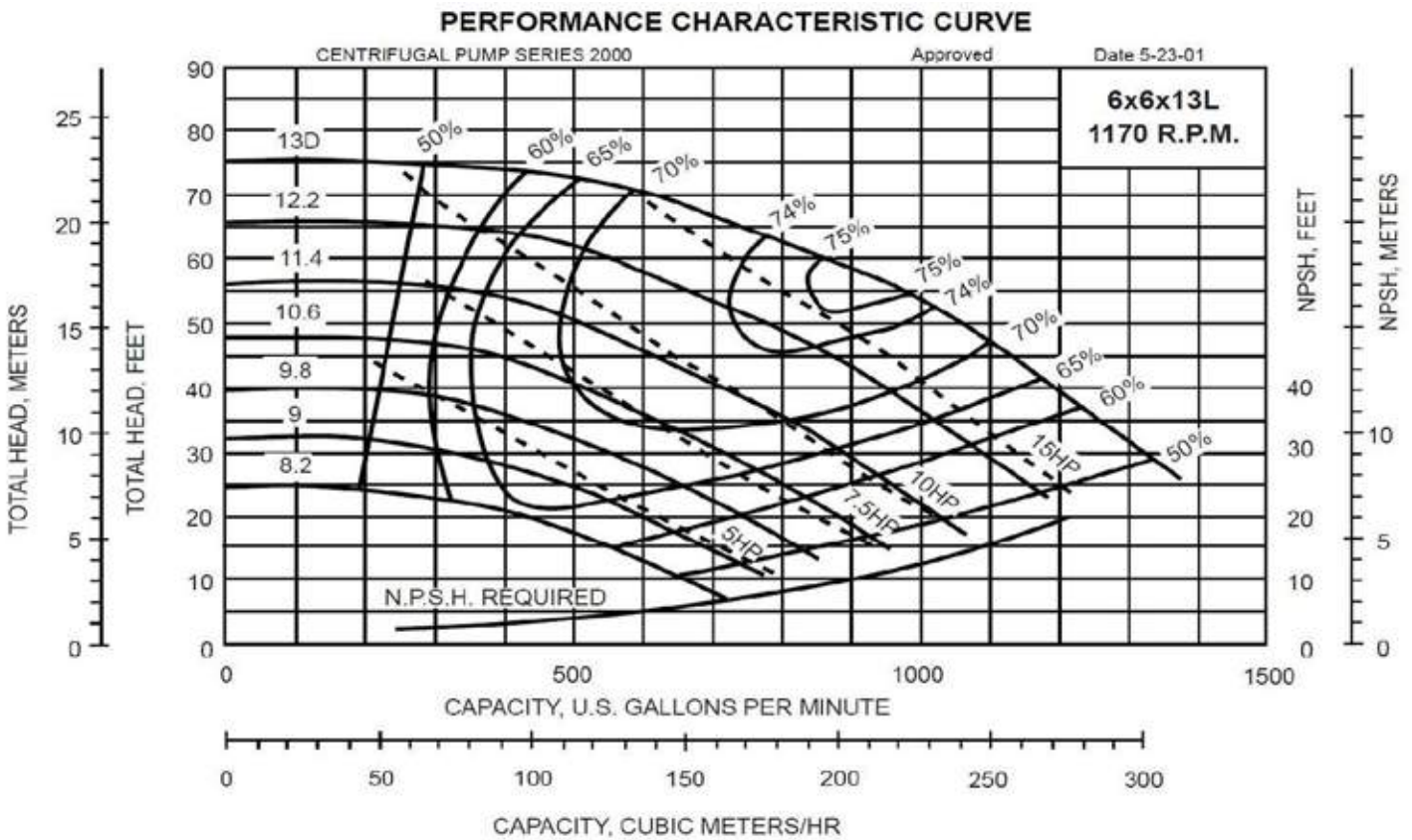
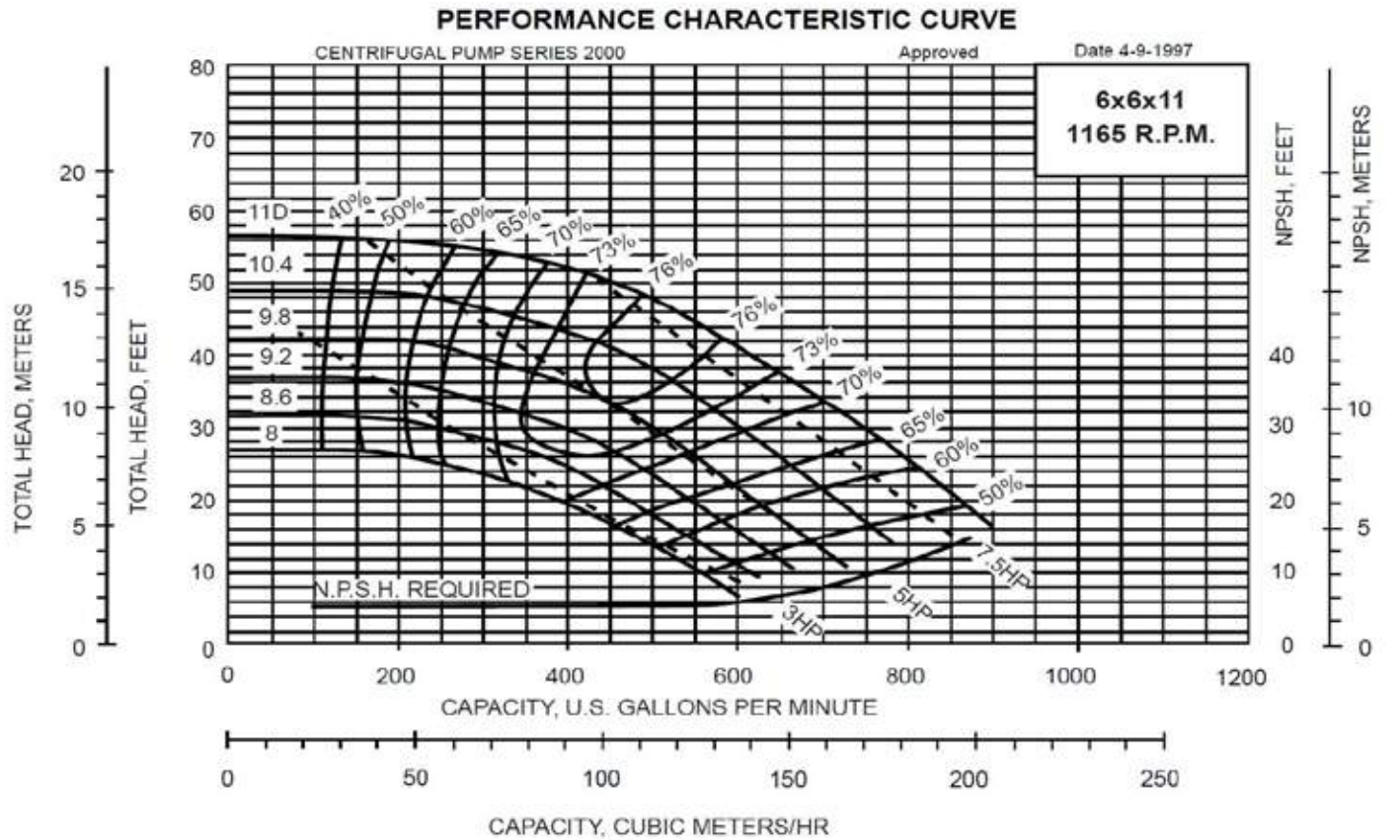

SERIES A-C 2000 - 60 Hz

1150 RPM PUMP CURVES

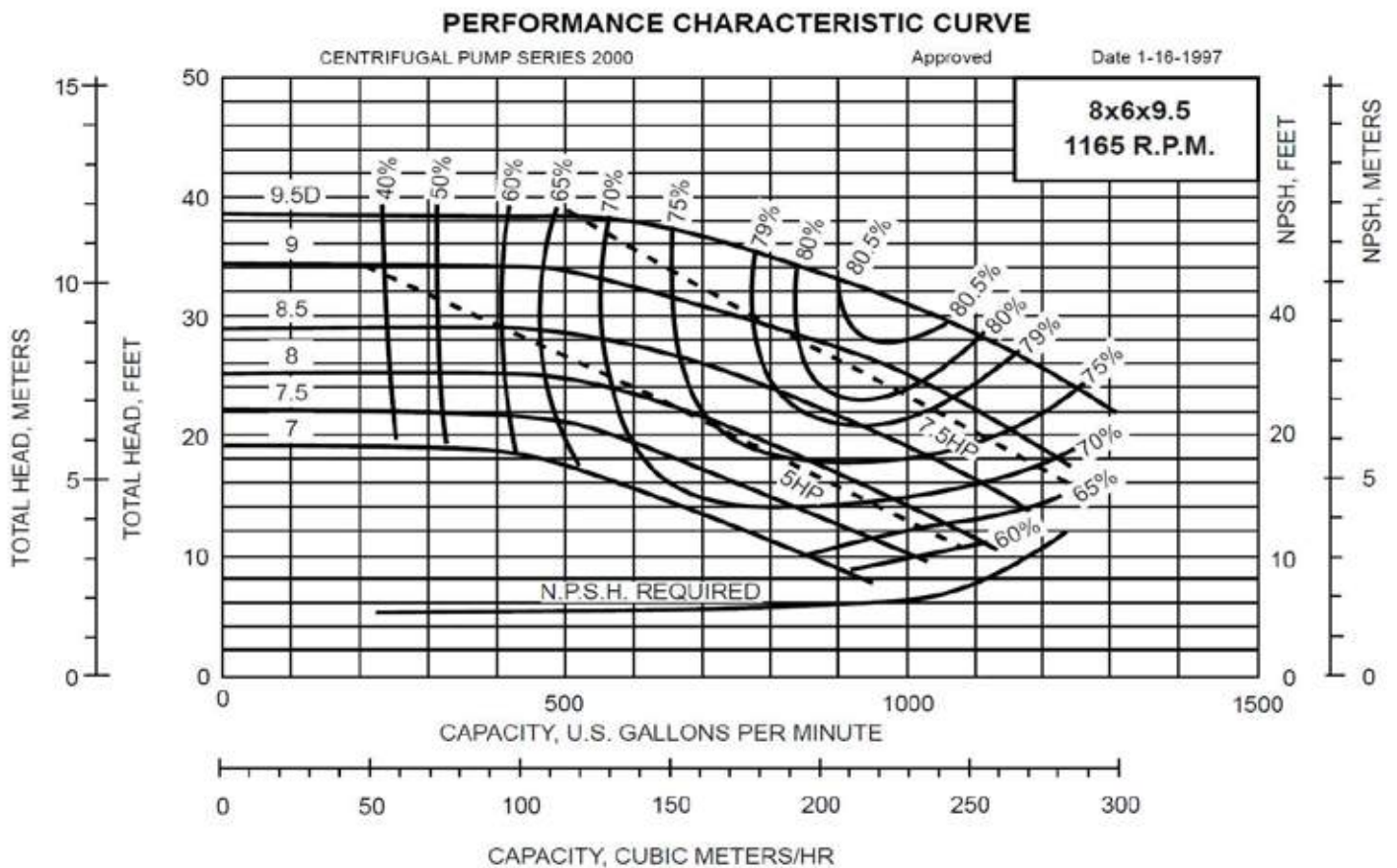
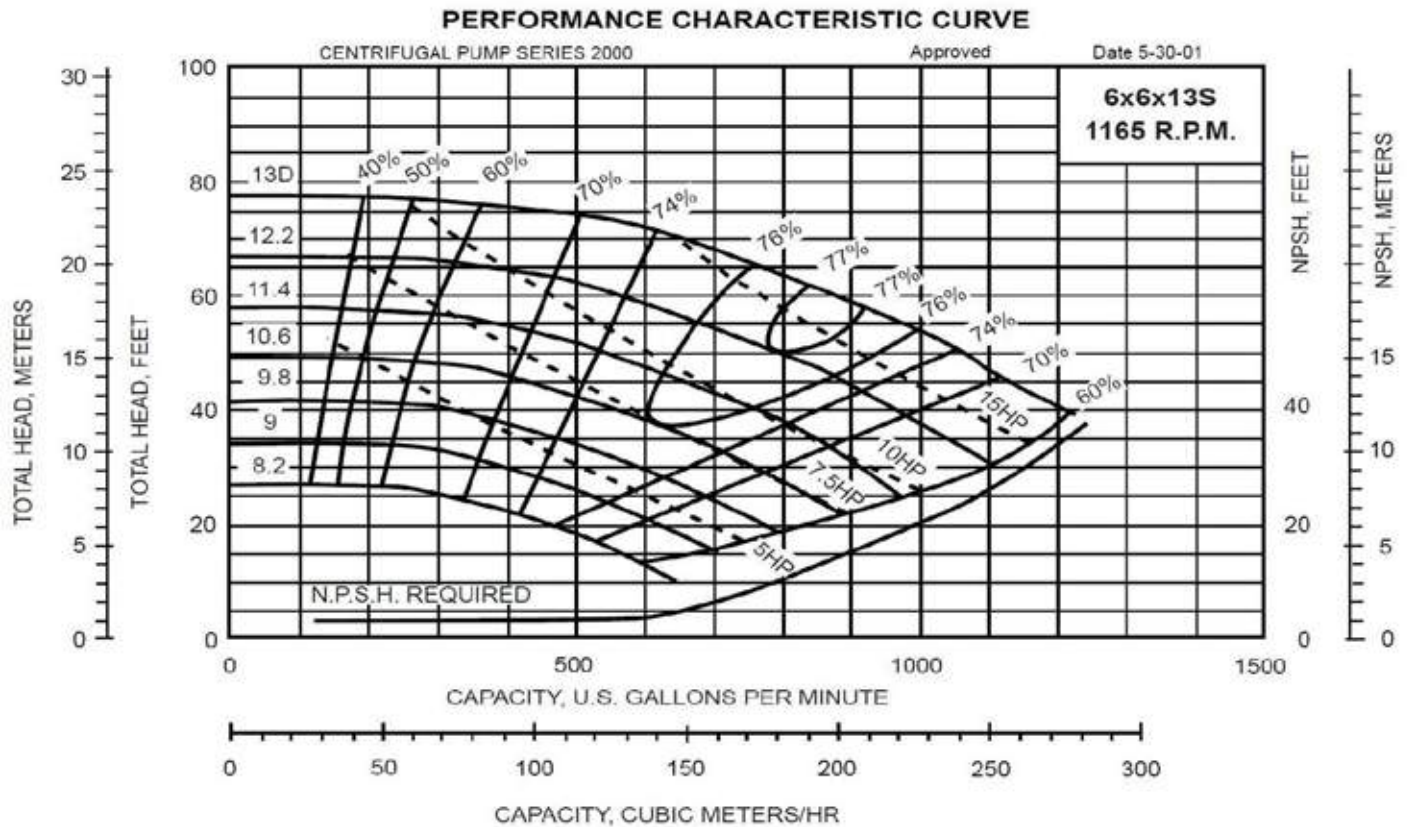

SERIES A-C 2000 - 60 Hz

1150 RPM PUMP CURVES

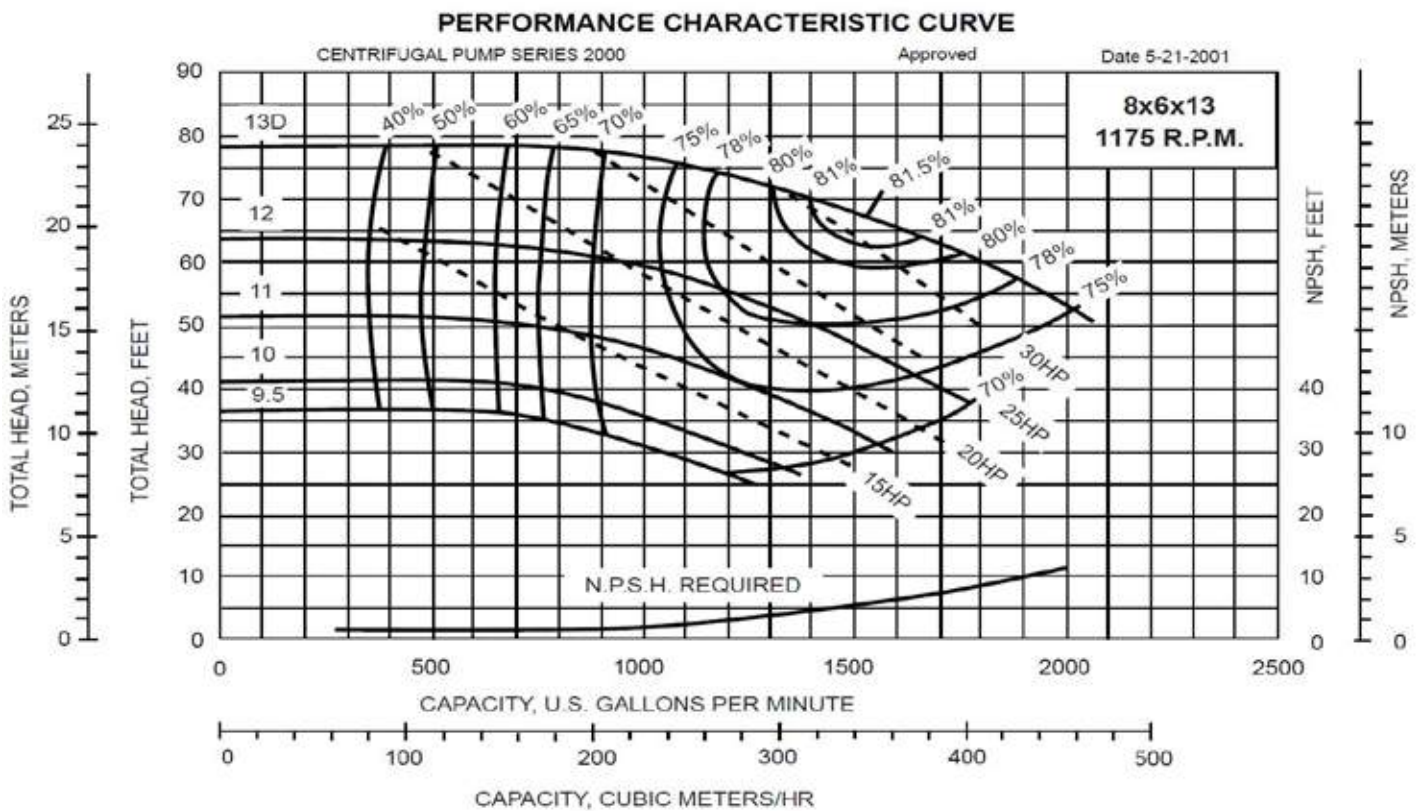
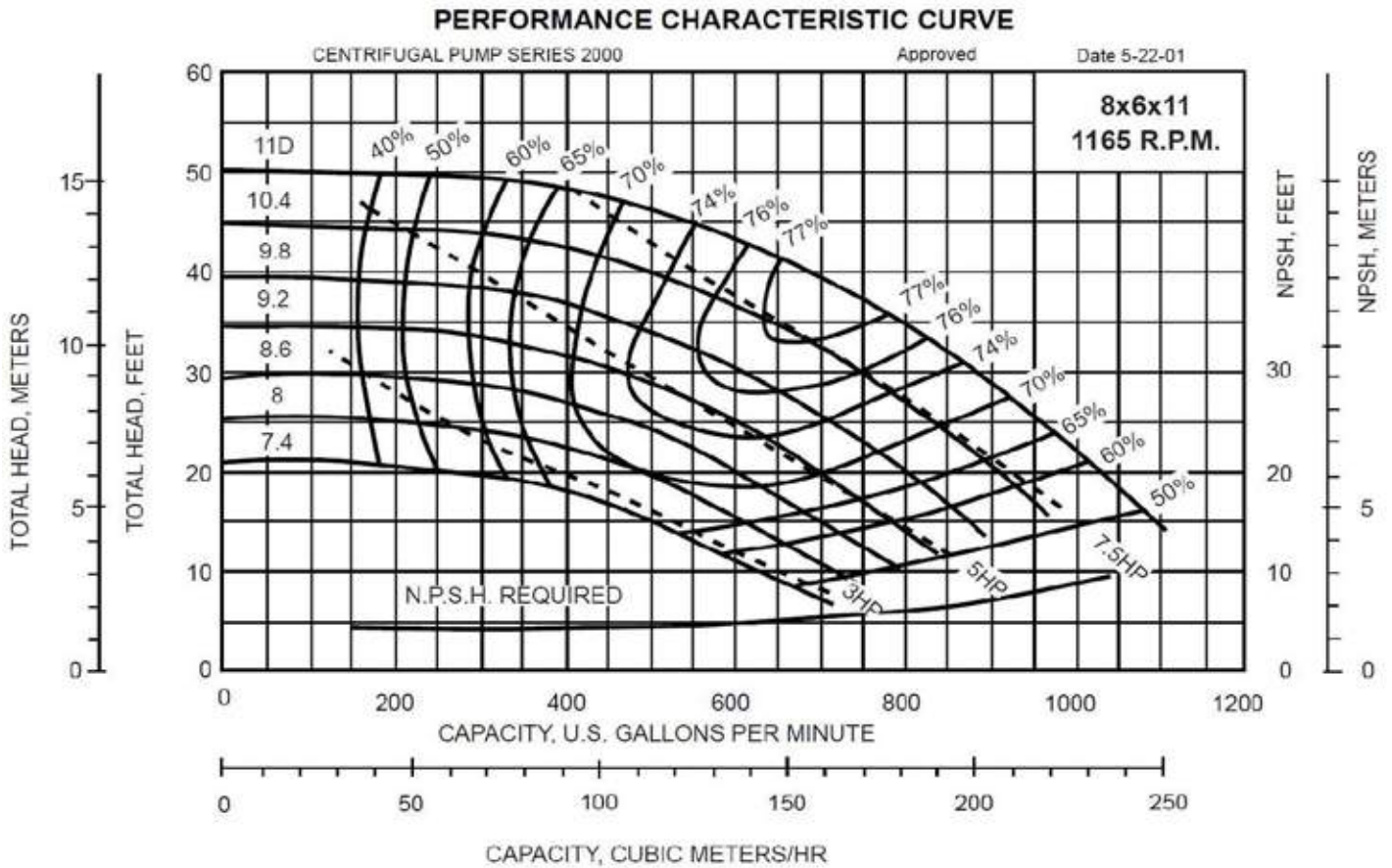

SERIES A-C 2000 - 60 Hz

1150 RPM PUMP CURVES

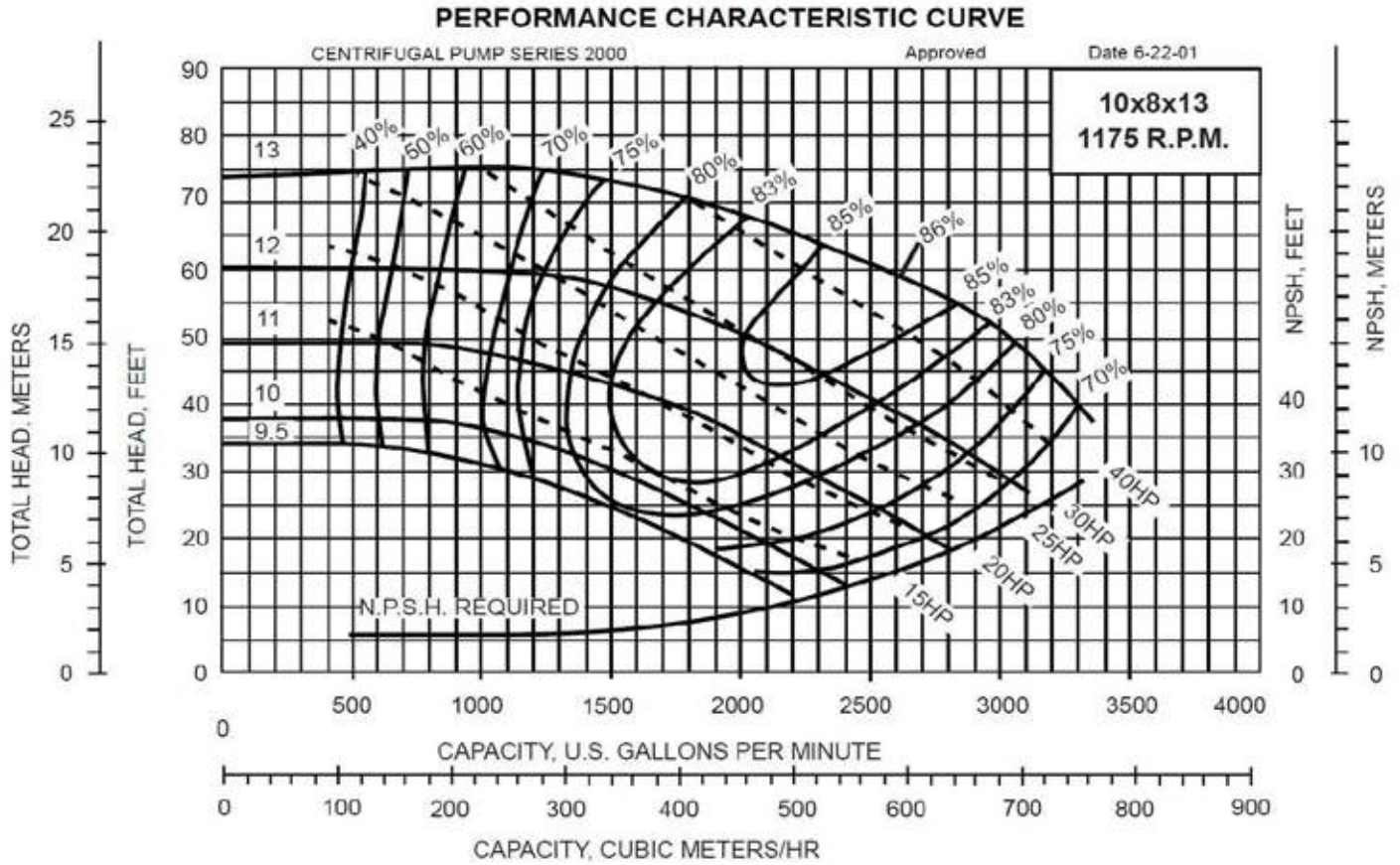

SERIES A-C 2000 - 60 Hz

3500 RPM PUMP CURVES

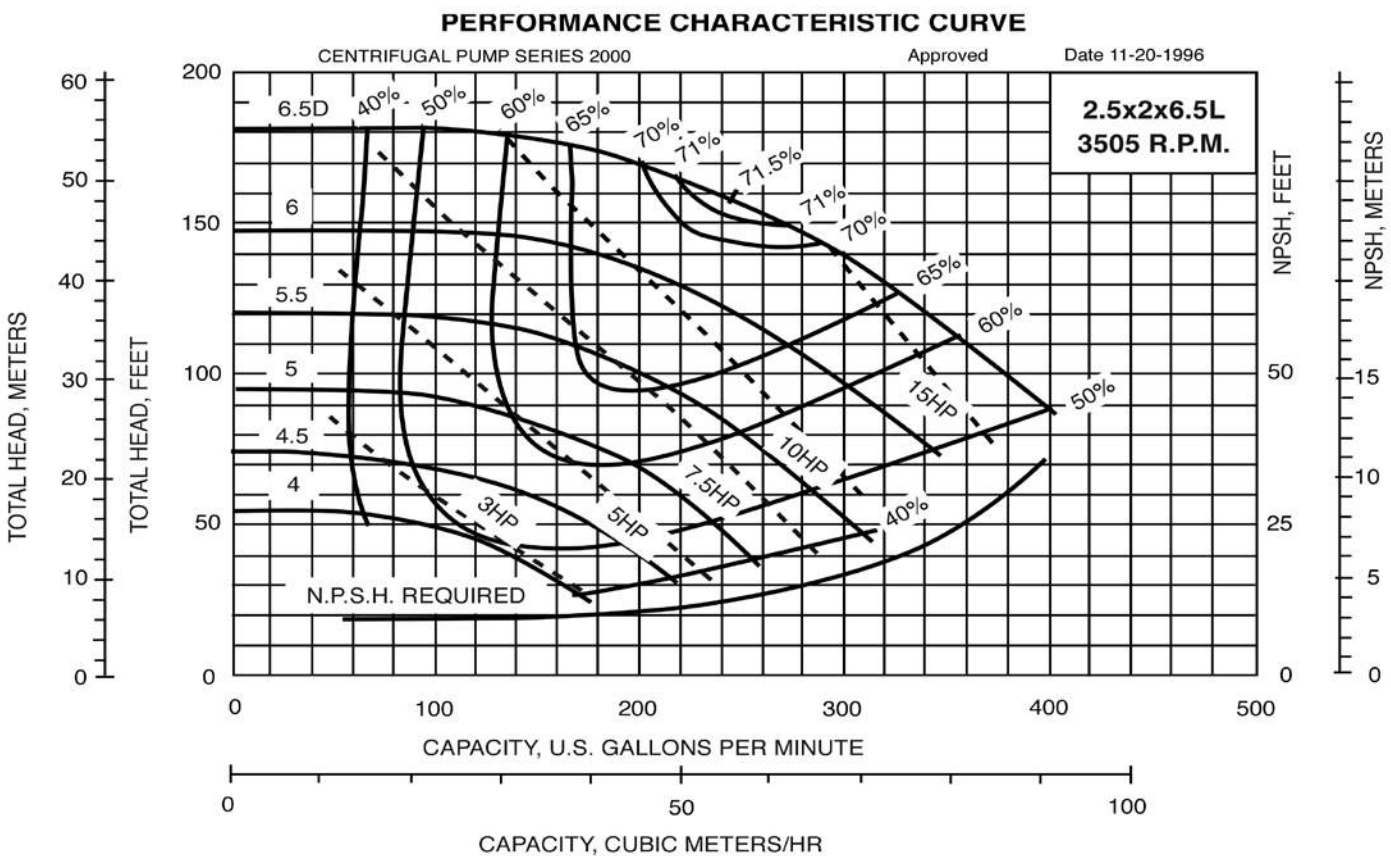
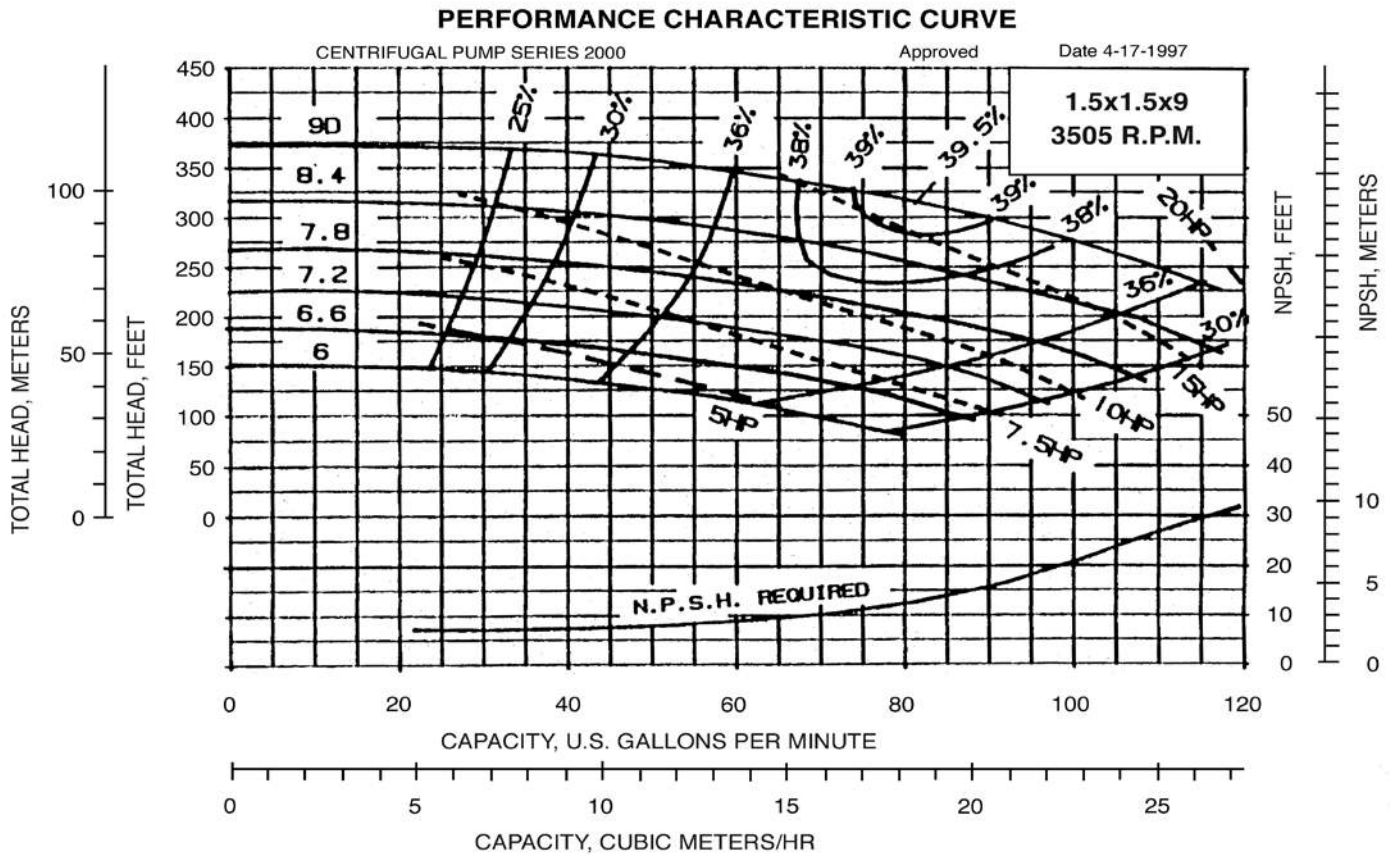

SERIES A-C 2000 - 60 Hz

3500 RPM PUMP CURVES

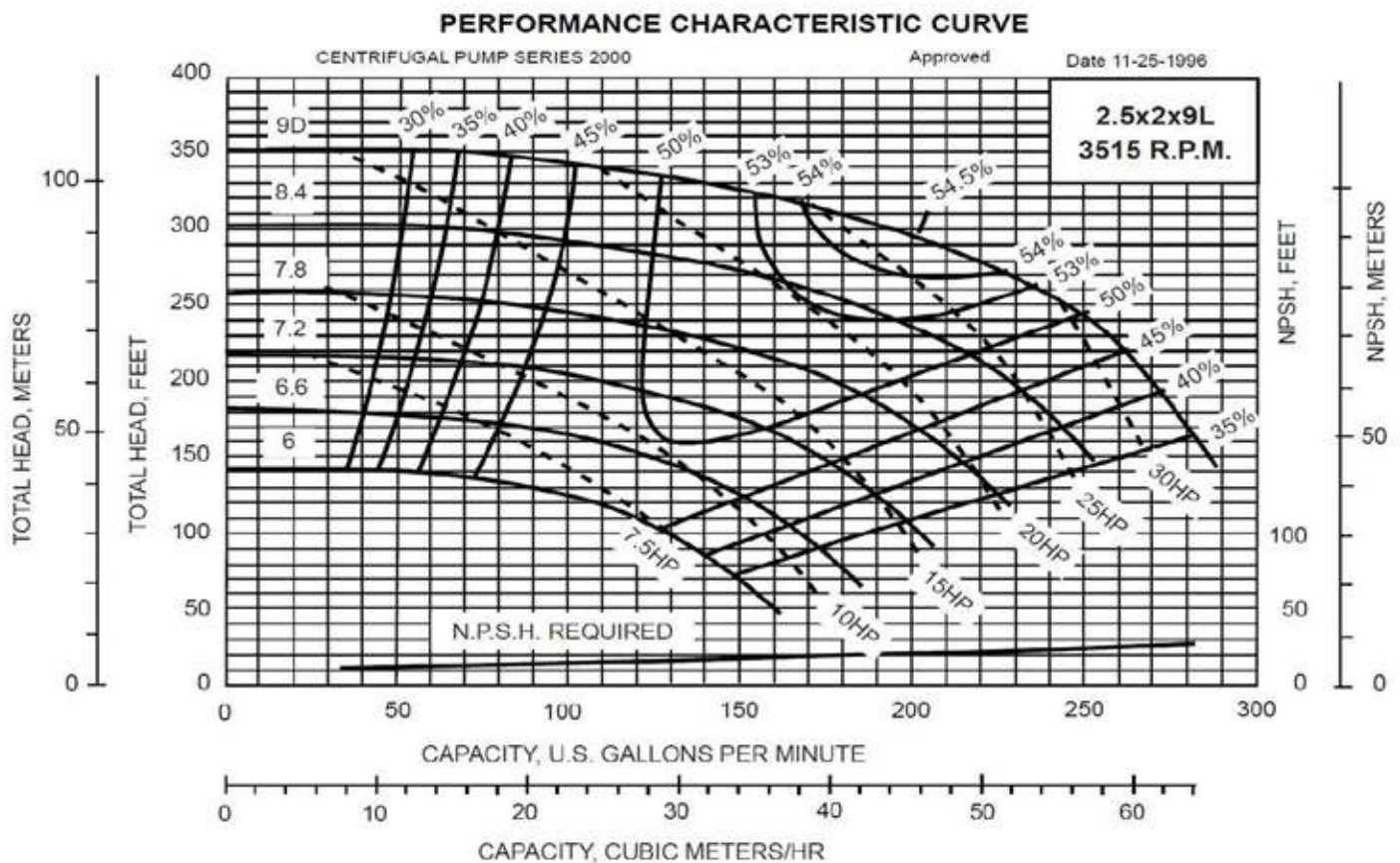
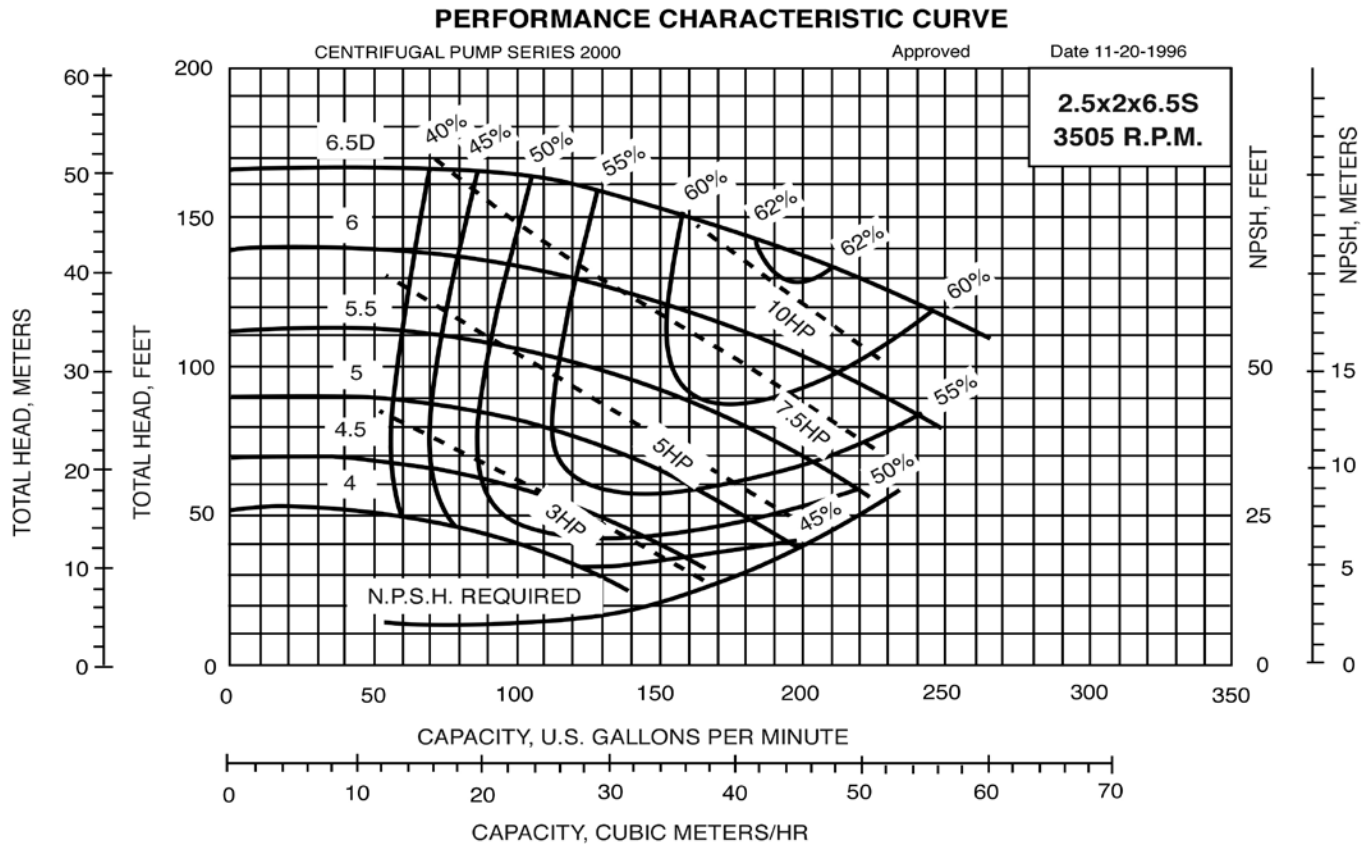

SERIES A-C 2000 - 60 Hz

3500 RPM PUMP CURVES

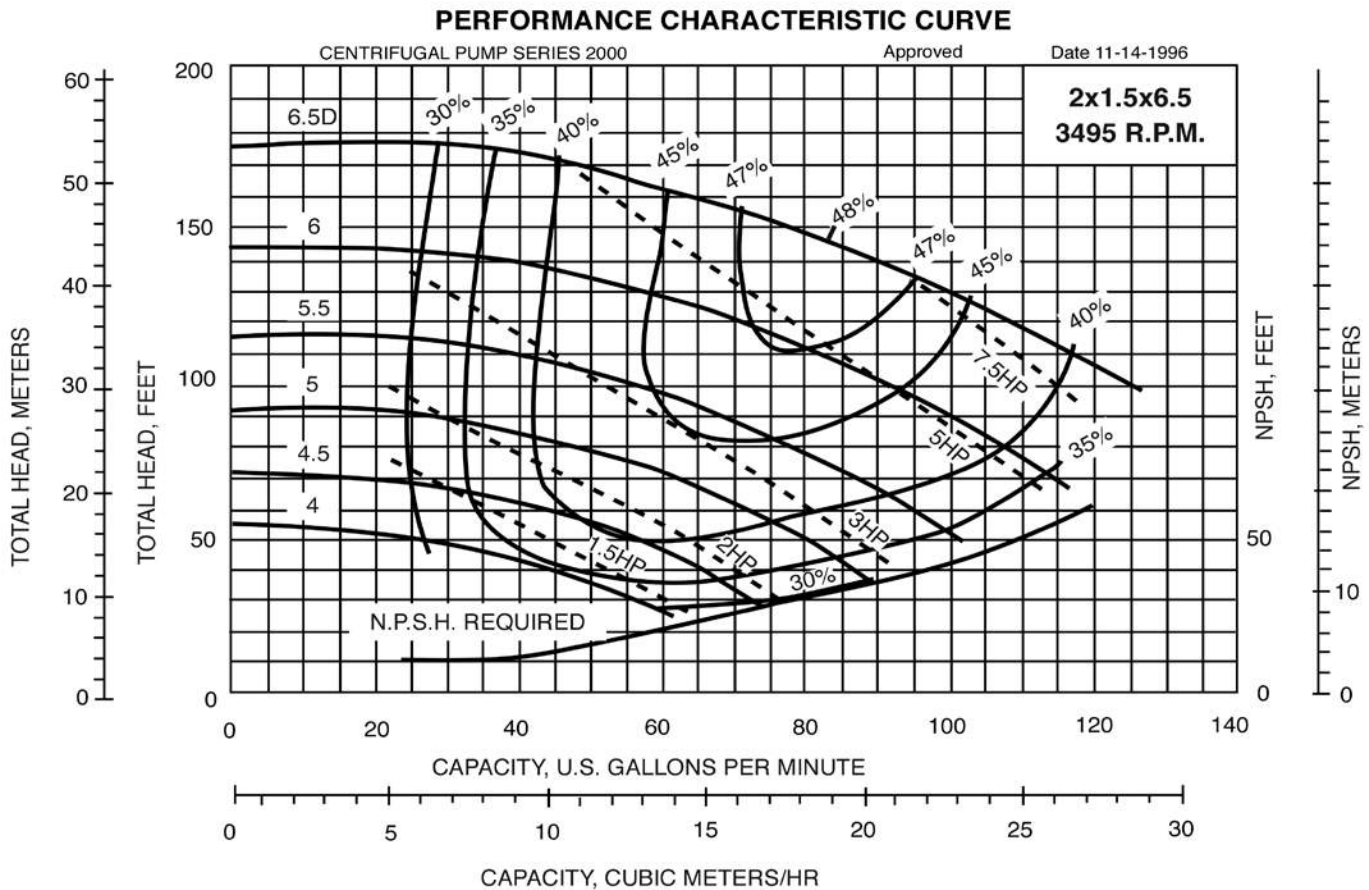
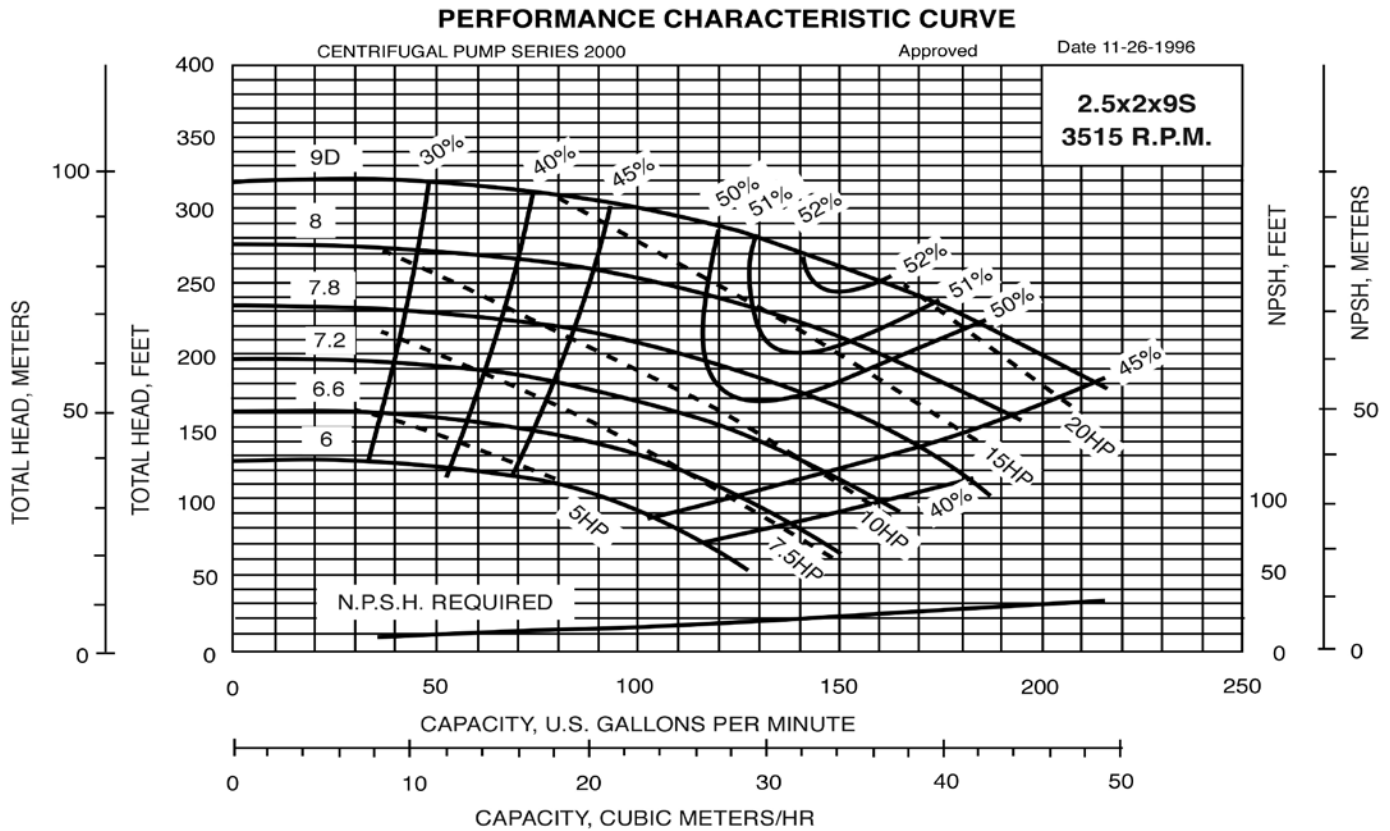

SERIES A-C 2000 - 60 Hz

3500 RPM PUMP CURVES

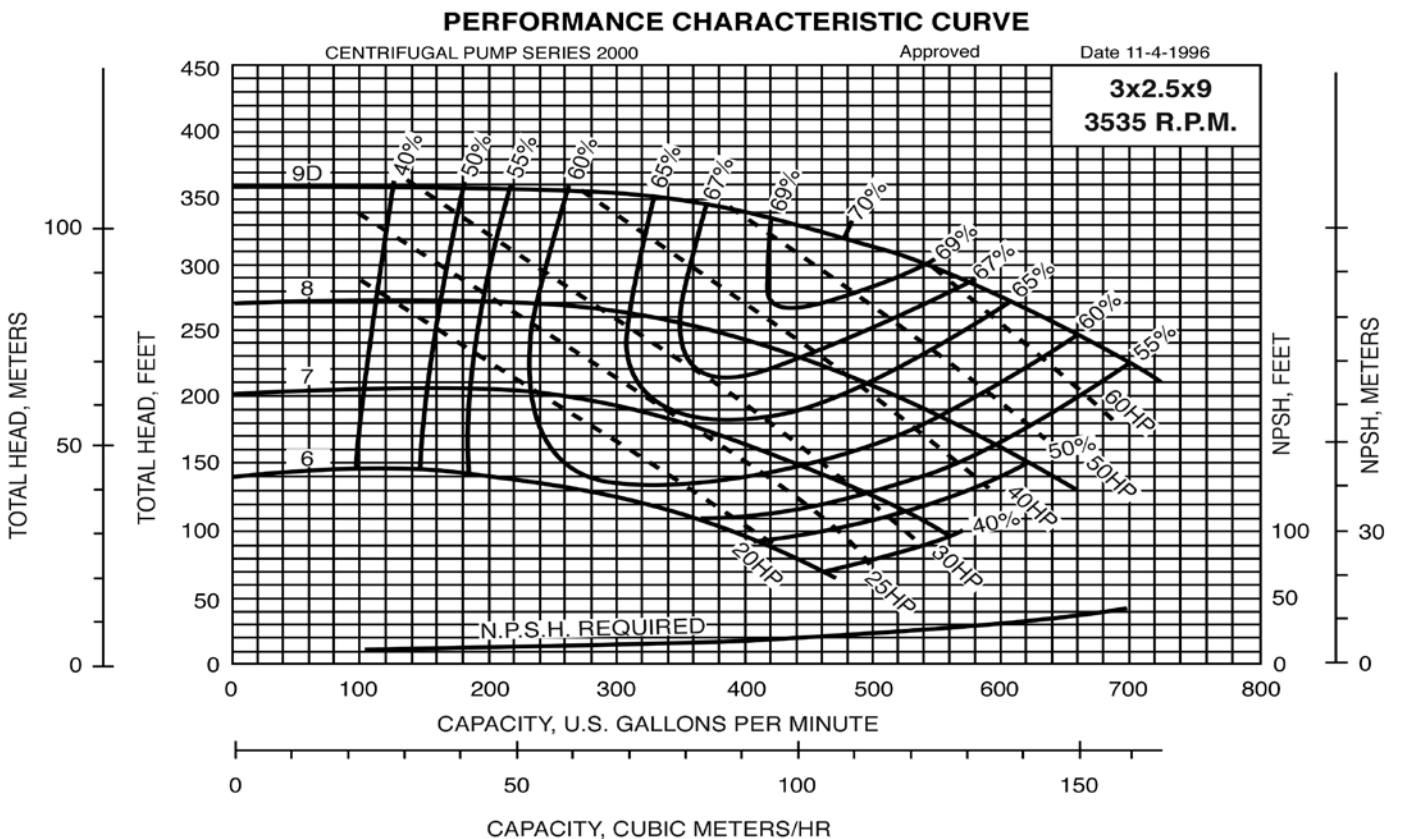
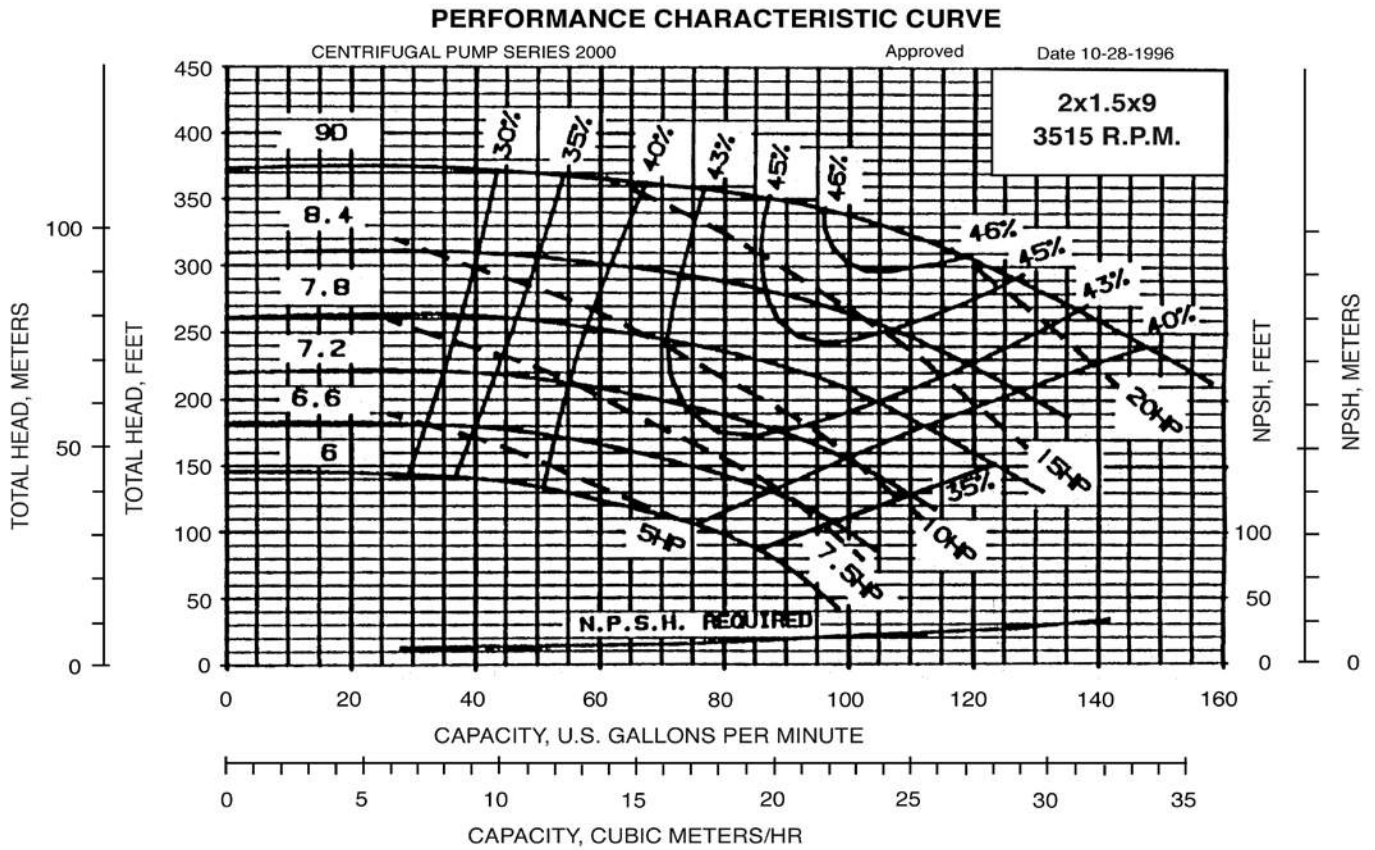

SERIES A-C 2000 - 60 Hz

3500 RPM PUMP CURVES

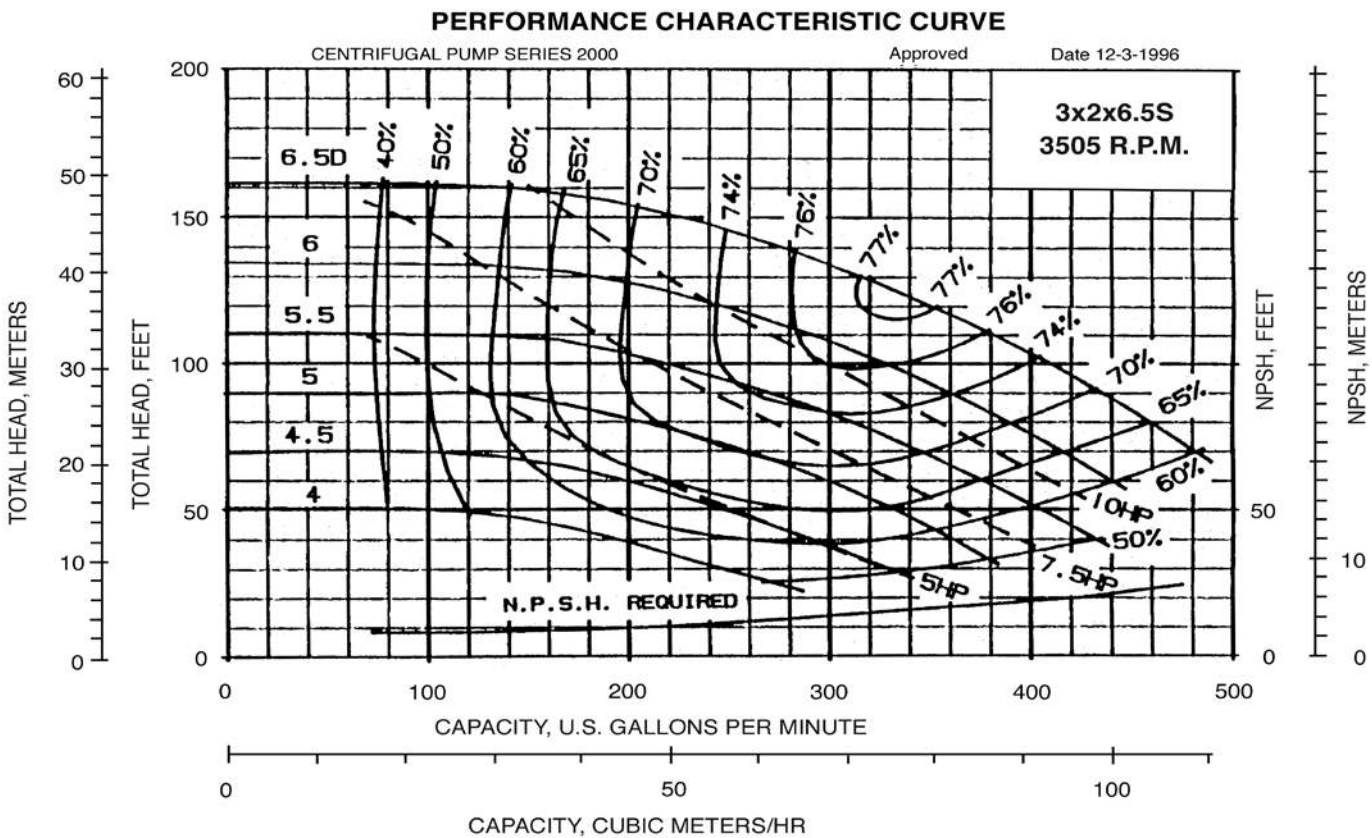
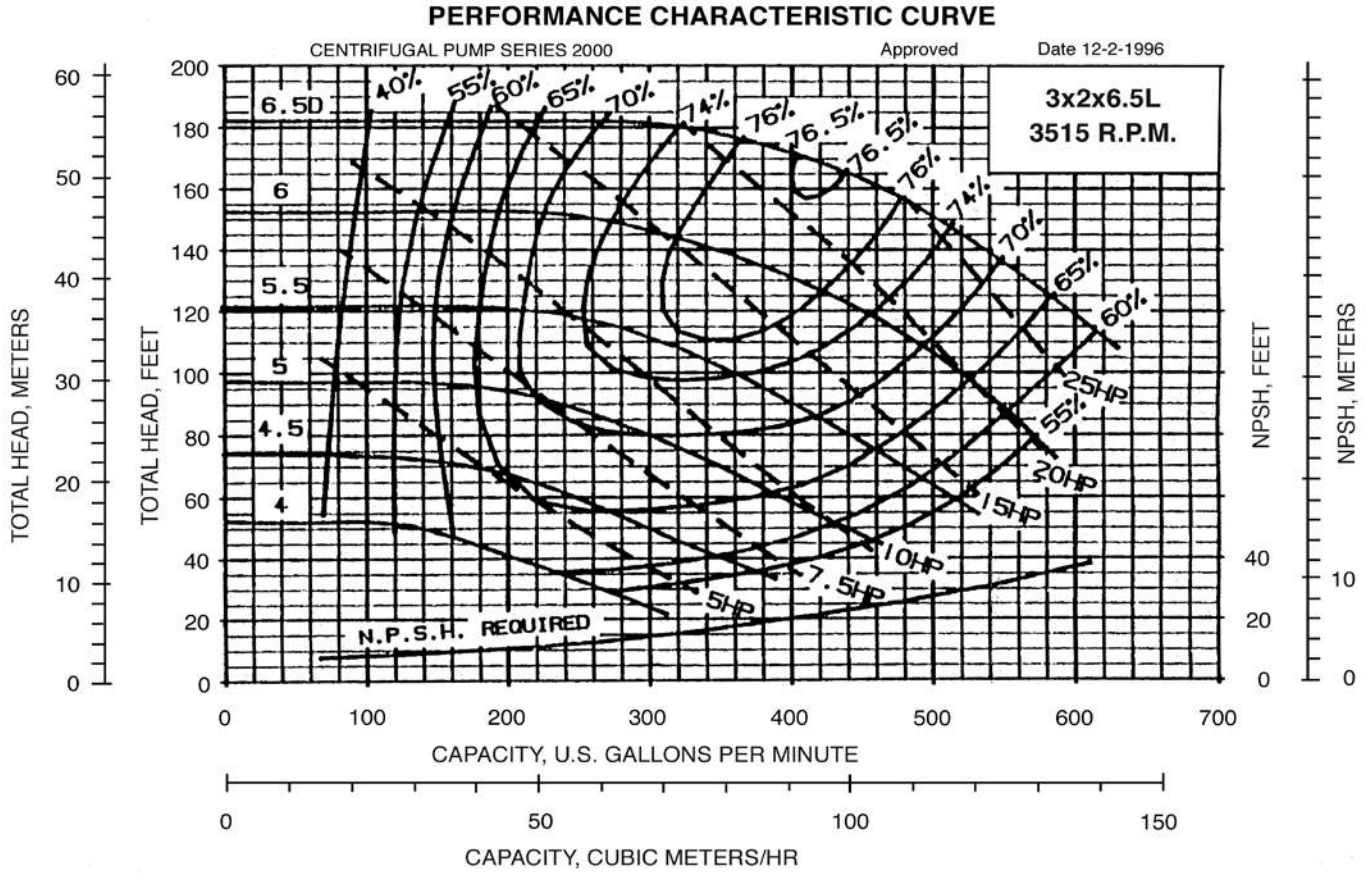

SERIES A-C 2000 - 60 Hz

3500 RPM PUMP CURVES

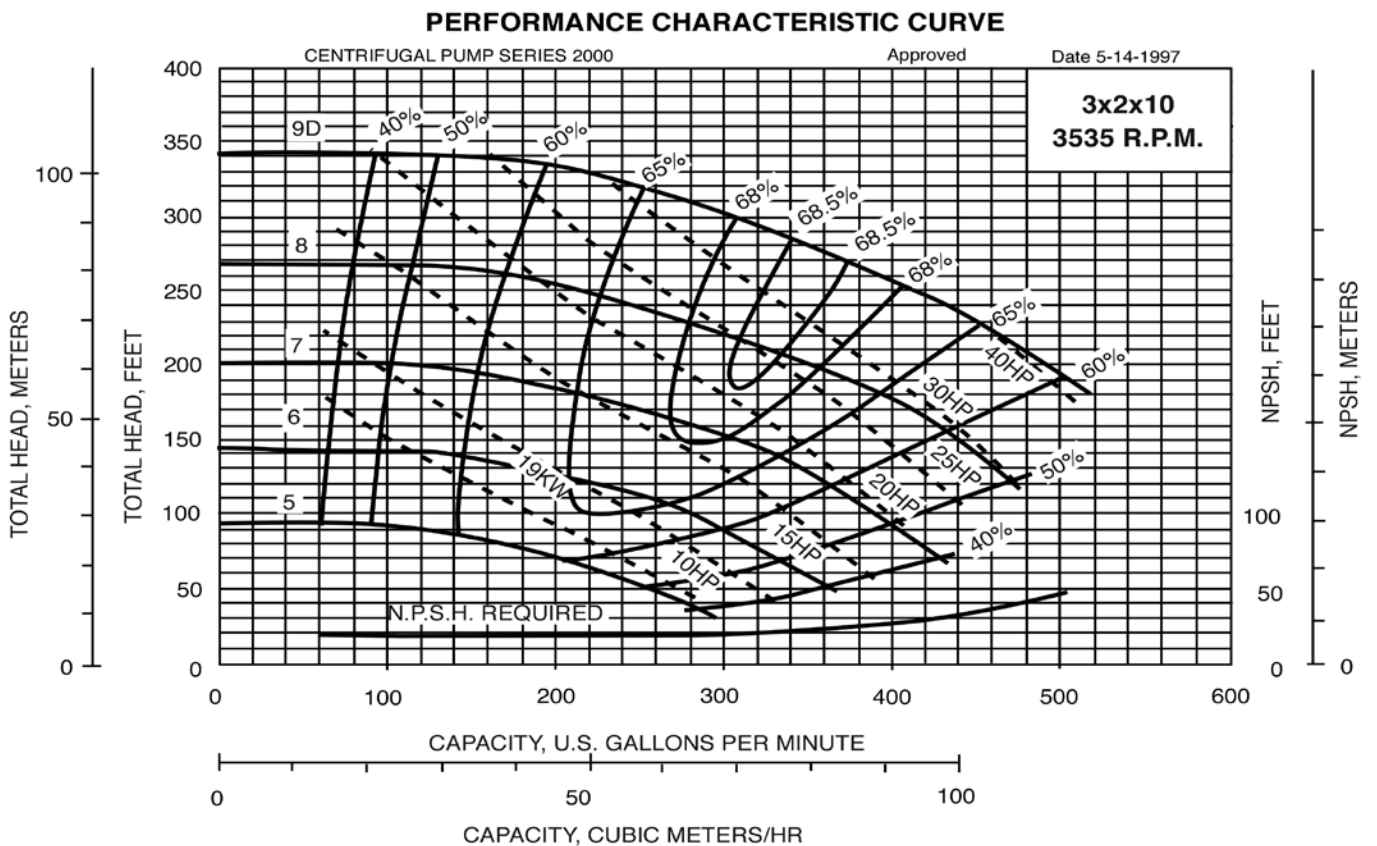
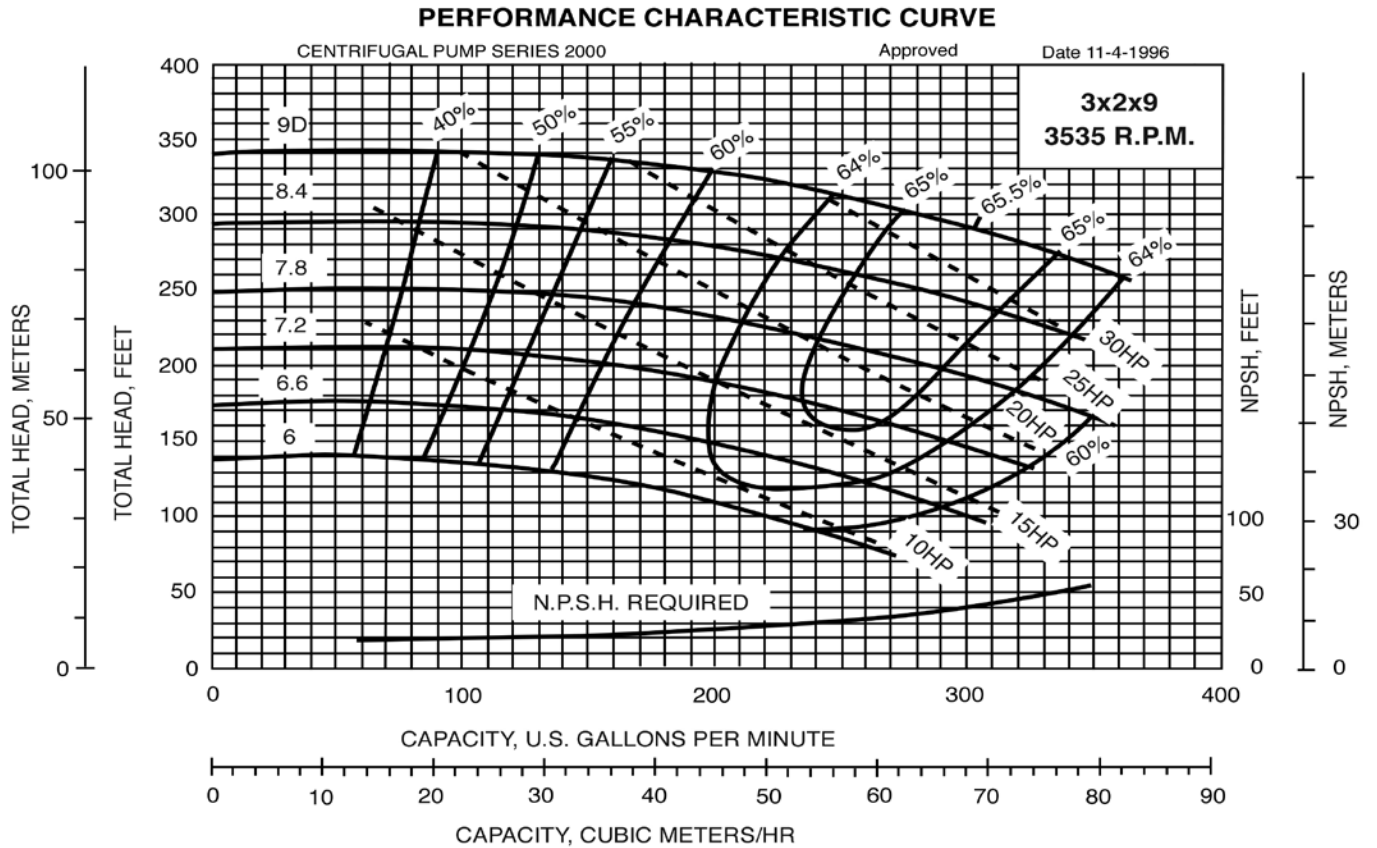

SERIES A-C 2000 - 60 Hz

3500 RPM PUMP CURVES

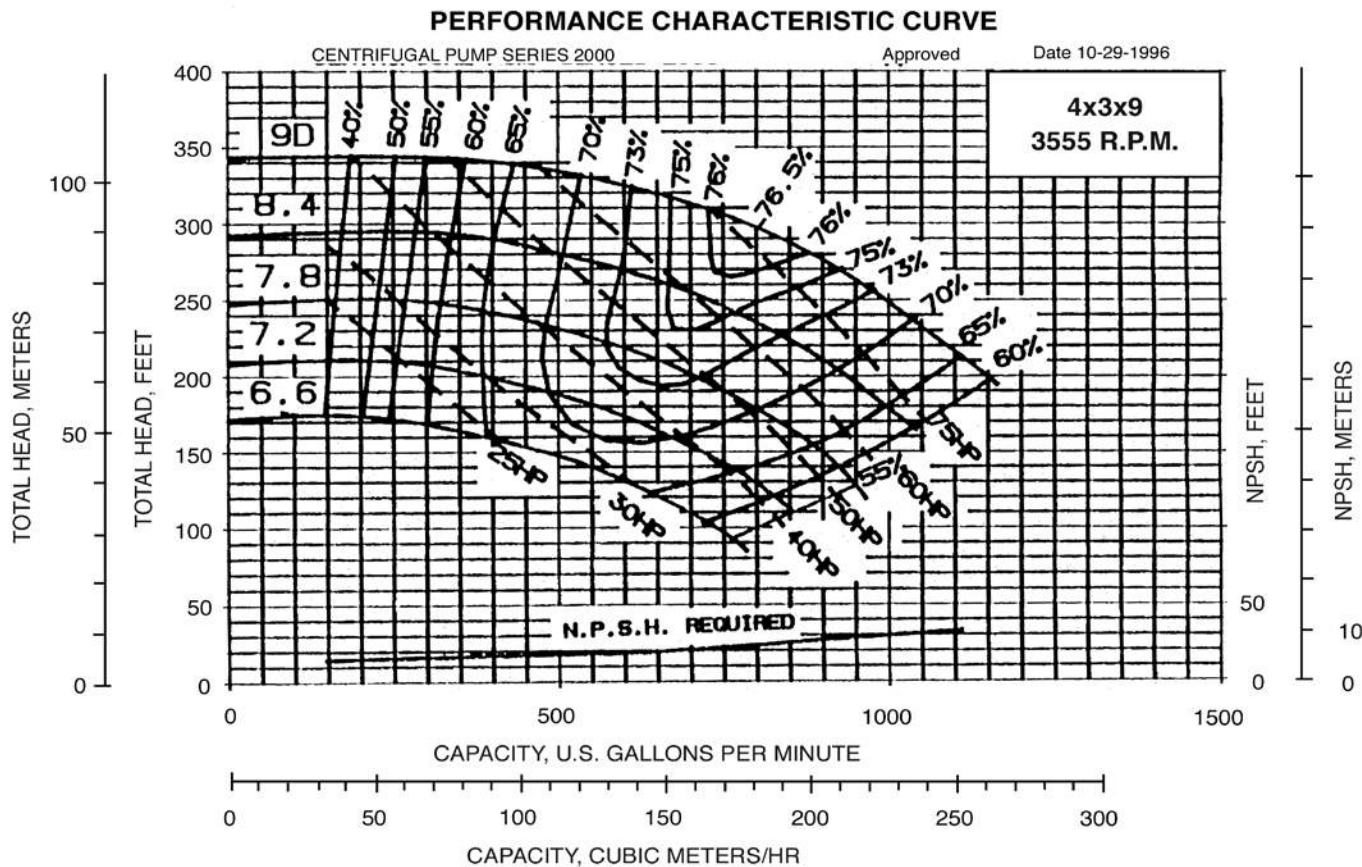
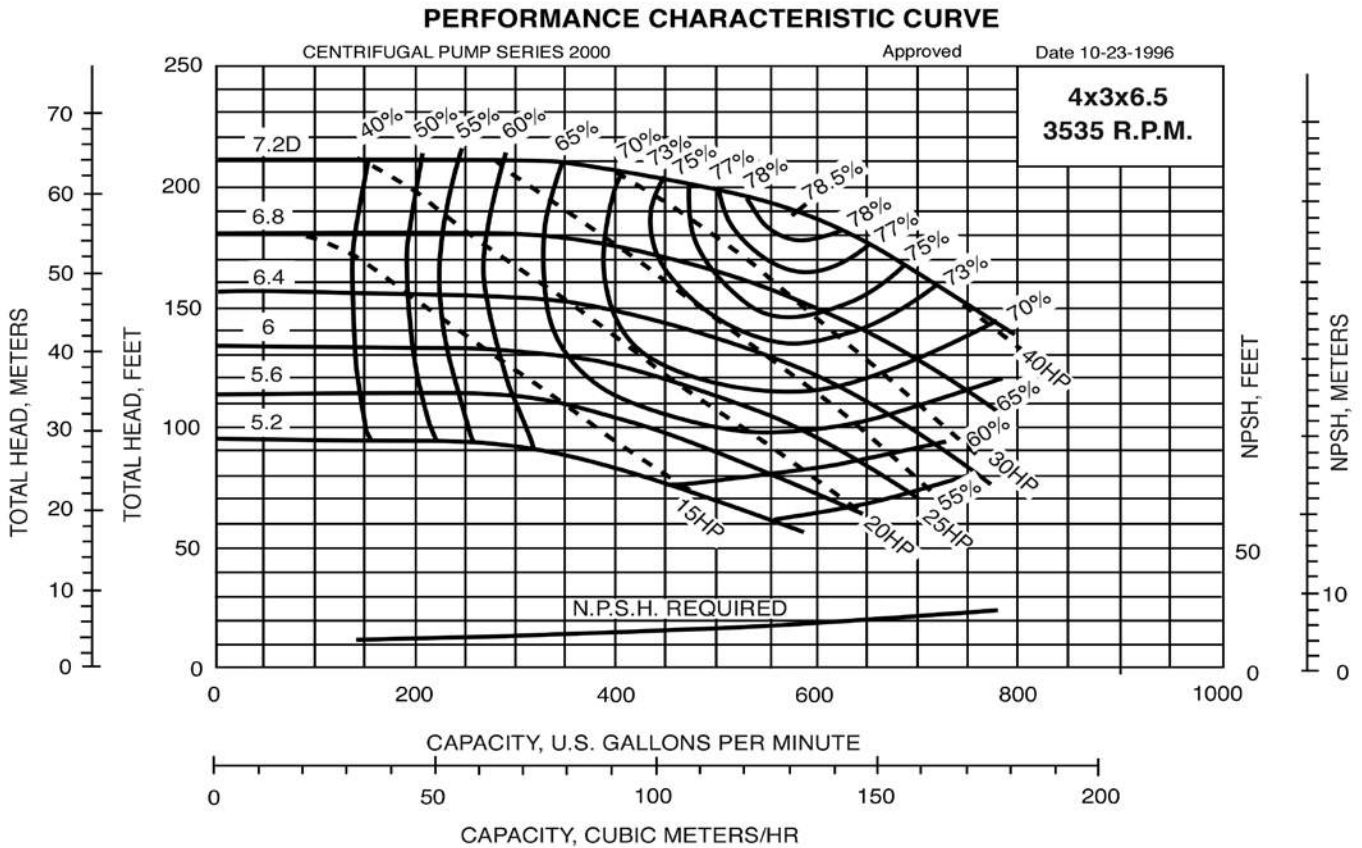

NOTES

NOTES

NOTES

Xylem |'zīləm|

- 1) The tissue in plants that brings water upward from the roots;
- 2) a leading global water technology company.

We're 12,500 people unified in a common purpose: creating innovative solutions to meet our world's water needs. Developing new technologies that will improve the way water is used, conserved, and re-used in the future is central to our work. We move, treat, analyze, and return water to the environment, and we help people use water efficiently, in their homes, buildings, factories and farms. In more than 150 countries, we have strong, long-standing relationships with customers who know us for our powerful combination of leading product brands and applications expertise, backed by a legacy of innovation.

For more information on how Xylem can help you, go to www.xyleminc.com



Xylem Inc.
2881 East Bayard Street Ext., Suite A
Seneca Falls, NY 13148
Phone: (800) 453-6777
Fax: (888) 322-5877
www.gouldswatertechnology.com

Goulds is a registered trademark of Goulds Pumps, Inc. and is used under license.
© 2013 Xylem Inc. CAC2000 R1 June 2014