

MOTOR SPEED PRODUCT LINE: CAST IRON PUMPS

SERIES 495, 4195

Section	1441
Page	1441.1
Issue	B

TABLE OF CONTENTS

Features & Benefits	2
Standard Materials of Construction	2
Cutaway View & Pump Features	3
Model Number Key	4
Specifications	4
Mounting Options.....	5
Dimensions – G, GG, H, HJ, HL Sizes (495).....	6
Dimensions – AS, AK, AL Sizes (495).....	6
Dimensions – G, GG, H, HJ, HL Sizes (4195)	7
Dimensions – AS, AK, AL Sizes (4195)	7
Dimensions – KE, KKE, LQE, LSE Sizes (4195)	8
Dimensions – Q, QS Sizes (4195).....	8
Dimensions – G, GG, H, HJ, HL Sizes – M Drive (495)	9
Dimensions – H, HJ, HL Sizes – IEC Frame M Drive (495)	9
Dimensions – AS, AK, AL Sizes – M Drive (495)	10
Dimensions – KE, KKE, LQE, LSE Sizes – Pump, M Drive, Motor (4195)	11
Dimensions – G, GG, H, HJ, HL, AS, AK, AL Sizes – D Drive (4195).....	12
Dimensions – KE, KKE, LQE, LSE, Q Sizes – D Drive (4195) ..	13
Dimensions – Q, QS Sizes – R Drive (4195)	13
NPSH Required	14
Expected Nominal Sound Levels for Motor Speed Pumps	14

SERIES DESCRIPTION

Viking's Motor Speed Product Line internal gear pumps represent a technological advance in the science of flow. Through new techniques of feeding the rotor and idler, Viking has achieved what was once considered impossible – high flow rates operating at motor speeds. The largest size (QS) operates at reduced speeds, but still faster than other pumps of similar displacement. Higher speeds mean greater value, with the ability to move more fluid with a smaller pump. It also enables close-coupling to a motor or gearmotor, which eliminates shaft misalignment and results in longer seal and bearing life by preventing wear due to misalignment.

RELATED PRODUCTS

Steel Externals, 493/4193 Series: Catalog Section 1341

Stainless Steel, 4197 Series: Catalog Section 1741

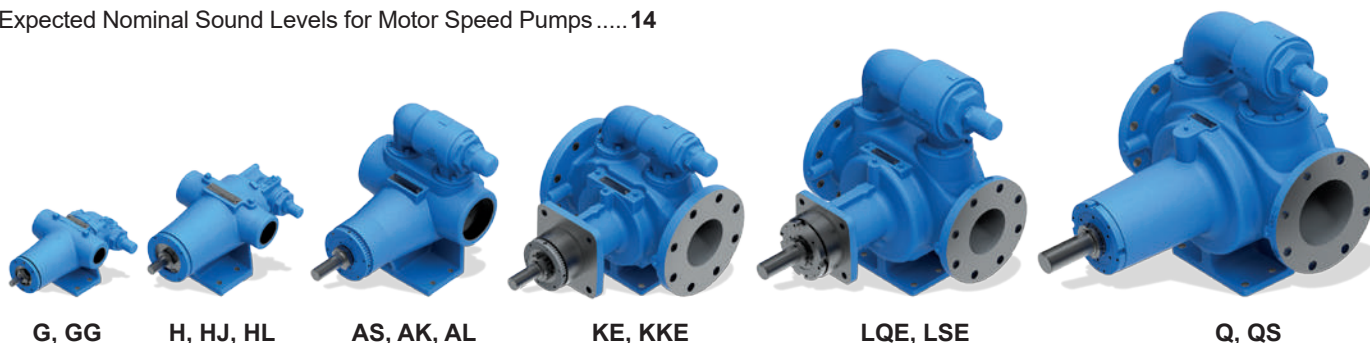

OPERATING RANGE

SERIES	NOMINAL FLOW		MAXIMUM PRESSURE		TEMPERATURE RANGE		VISCOSITY RANGE*	
	GPM	m ³ h	PSI	Bar	°F	°C	SSU	cSt
495	8 - 115	1.8 - 26	250	17	-40 to +300	-40 to +150	28 to 15,000	1 to 3,300
4195	8 - 580	1.8 - 132	250	17	-40 to +300	-40 to +150	28 to 15,000	1 to 3,300

* 25,000 SSU (5,500 cSt) for KE-LSE & QS, 7,500 SSU (1,700 cSt) for Q

Section	1441
Page	1441.2
Issue	B

**MOTOR SPEED PRODUCT LINE:
CAST IRON PUMPS
SERIES 495, 4195**

FEATURES & BENEFITS

- Direct drive with no gear reducer (with 60 Hz 4 pole motor to 205 GPM / 47 m³/h, 6 pole motor to 350 GPM / 80 m³/h, 8 pole motor to 460 GPM / 104 m³/h)
 - » Reduces cost of installation
 - » Eliminates one shaft alignment
 - » Eliminates one set of couplings and coupling guard
 - » Reduces footprint
 - » Eliminates gearbox lubrication and maintenance
- Close-couple to C-face motor or gearmotor at flows to 350 GPM / 80 m³/h
 - » Eliminates all shaft misalignment and coupling guards
 - » Keeps shafts aligned for longer seal and bearing life
 - » Simplifies mounting on skid frame without extra baseplate
 - » Enables vertical mounting for smallest footprint (up to 350 GPM / 80 m³/h)
- Heavy duty design with sealed-for-life bearings
 - » No relubrication required
 - » Thrust control enables pressures to 250 PSI / 17 BAR (G-AL sizes) or 150 PSI / 10 BAR (KE-QS sizes)
 - » Enables end clearance adjustment for viscosity or to compensate for wear over time
- Gauge ports standard on all sizes.
 - » Allows easy application of gauges or transducers
- Behind-the-rotor mechanical seals with FKM elastomers and Carbon/SiC faces as standard
 - » Eliminates bracket bushing, enables use of antifriction bearing external to liquid
 - » Heavy duty seal provides broad application, long life
 - » Casing weep hole between seal and forward bearing enables detection of seal leakage, prevents intrusion into sealed bearing
- KE-QS sizes are available with ANSI or DIN flanges. No piping adaptors required to conform to local standards
- Opposite porting enables easy in-line mounting to almost any piping system
- Pressure lubricated idler pin lubricates the idler pin/bushing interface to extend life on thin liquids (AS-QS Sizes)
- Static O-ring seals ensure maximum sealing capability on thin liquids (flat gaskets furnished on relief valve only on G-HL sizes)
- Hardened steel idler on KE-QS sizes provides maximum service life and helps protect against cavitation wear on low NPSHa applications

STANDARD MATERIALS OF CONSTRUCTION

Component	Standard Material
Bracket / Casing	Cast Iron, ASTM A48, Class 35B
Head	Cast Iron, ASTM A48, Class 35B
Rotor Shaft	Steel, ASTM A108, Grade 1045
Rotor	Cast Iron, ASTM A48, Class 35B (G, GG, H, HJ, KE, LQE, Q) Ductile Iron, ASTM A536 Grade 60-40-18 (HL, AS, AK, AL, KKE, LSE, QS)
Idler	Powdered Metal MPIF 35, FN-0208-45 (G, GG) Powdered Metal MPIF 35, FC-0208-50 (H, HJ, HL) Ductile Iron, ASTM A536 Grade 60-40-18 (AS, AK, AL) Hardened Steel, ASTM A148, Grade 80-50 (KE, KKE, LQE, Q, QS) Hardened Steel, ASTM A148, Grade 80-40 (LSE)
Idler Pin	Hardened Steel, ASTM A108, Grade 1045
Idler Bushing	Carbon Graphite
Pressure Relief Valve	Cast Iron, ASTM A48, Class 35B
Mechanical Seal Faces	Carbon vs. Ni-Resist (G-AL), Carbon vs. Silicon Carbide (KE-QS)
Elastomers	FKM
Antifriction Bearings	Steel with Buna Seals

MOTOR SPEED PRODUCT LINE: CAST IRON PUMPS

SERIES 495, 4195

Section	1441
Page	1441.3
Issue	B

CUTAWAY VIEW & PUMP FEATURES

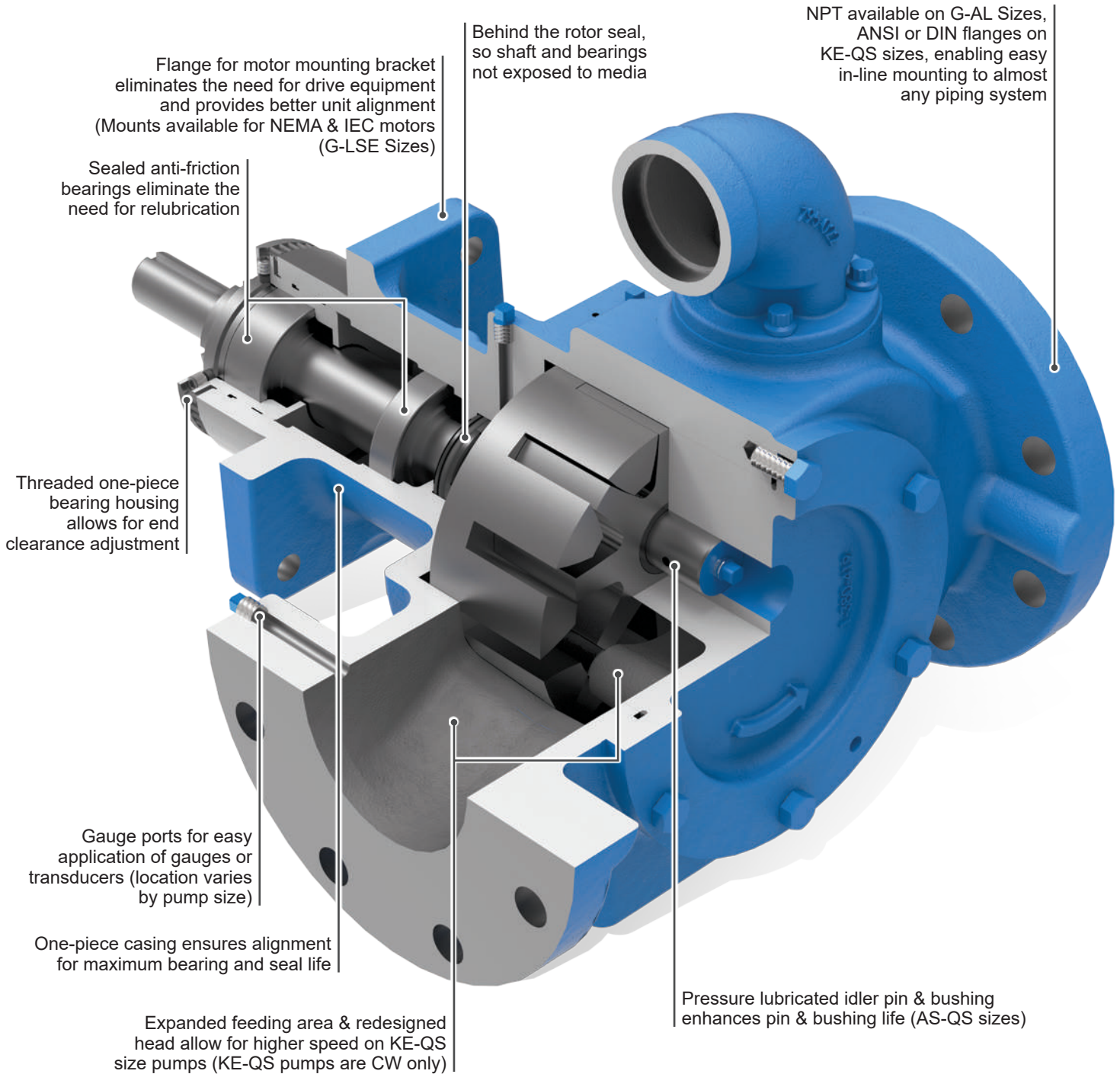

Section	1441
Page	1441.4
Issue	B

MOTOR SPEED PRODUCT LINE: CAST IRON PUMPS

SERIES 495, 4195

MODEL NUMBER KEY

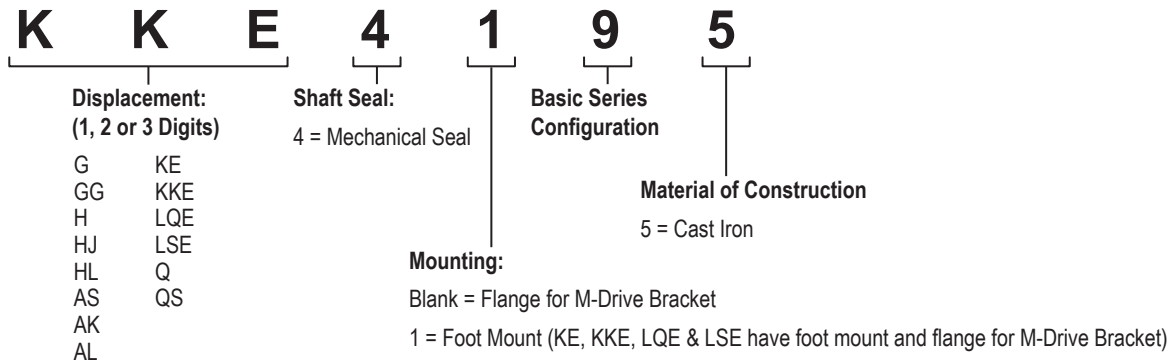

SPECIFICATIONS

Model Number	① Standard Ports		Nominal Pump Rating (100 SSU & below)						③ Maximum Differential Pressure		⑤ Maximum Hydrostatic Pressure		Maximum Temperature		Approx. Shipping Weight with Valve	
	Port Size	Port Type	60 Hz			50 Hz			PSIG	BAR	PSIG	BAR	°F	°C	Lbs.	Kg.
			GPM	m³/h	RPM	GPM	m³/h	RPM								
G4195 ② G495	1 in.	NPT	8	1.8	1750	7	1.5	1450	250	17	400	27	300	150	20	9
GG4195 ② GG495	1 in.	NPT	10	2.3	1750	8	1.9	1450	250	17	400	27	300	150	20	9
H4195 ② H495	1½ in.	NPT	15	3.4	1750	12	2.8	1450	250	17	400	27	300	150	44	20
HJ4195 ② HJ495	1½ in.	NPT	20	4.5	1750	17	3.8	1450	250	17	400	27	300	150	44	20
HL4195 ② HL495	1½ in.	NPT	30	6.8	1750	25	5.6	1450	250	17	400	27	300	150	44	20
AS4195 ② AS495	2½ in.	NPT	55	12	1750	45	10	1450	250	17	400	27	300	150	85	39
AK4195 ② AK495	2½ in.	NPT	85	19	1750	70	16	1450	250	17	400	27	300	150	85	39
AL4195 ② AL495	3 in.	NPT	115	26	1750	95	22	1450	250	17	400	27	300	150	86	39
④ KE4195	4 in. (100 mm)	① Flange	150	34	1750	125	28	1450	150	10	300	20	300	150	132	60
④ KKE4195	4 in. (100 mm)	① Flange	205	47	1750	170	39	1450	150	10	300	20	300	150	133	60
④ LQE4195	4 in. (100 mm)	① Flange	235	53	1150	195	44	960	150	10	300	20	300	150	220	100
④ LSE4195	4 in. (100 mm)	① Flange	350	80	1150	290	67	960	150	10	300	20	300	150	222	101
④ Q4195	6 in. (150 mm)	① Flange	460	104	750	460	104	750	150	10	300	20	300	150	443	201
④ QS4195	6 in. (150 mm)	① Flange	580	132	640	580	132	640	150	10	300	20	300	150	450	204

① Flange ports are suitable for use with Class 125 ANSI (inch) or DIN PN-16 (mm) cast iron companion flanges or flanged fittings. Optional Class 250 or DIN PN-25/40.

② 495 models require motor mount bracket, do not have mounting foot. KE, KKE, LQE, LSE 4195 models have both mounting flange for motor bracket and a mounting foot.

③ If suction pressures exceed 100 PSI (7 BAR), consult factory.

④ These sizes can only operate in one direction (clockwise only).

⑤ Maximum hydrostatic pressure for standard pump construction. Rating is dependent on seal, gaskets and ports.

MOTOR SPEED PRODUCT LINE: CAST IRON PUMPS

SERIES 495, 4195

Section	1441
Page	1441.5
Issue	B

MOUNTING OPTIONS

Flange Motor Mount Units (M-Drive)

Pump and motor mounted to a flange mounting bracket with coupling.

Sizes: G - AL495 & KE-LSE4195

See chart below for pump sizes and flange mounting brackets available by motor frame.

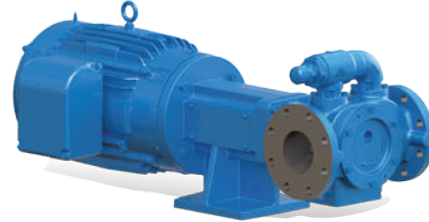

① Pump Model Number - Mounting Flange for Motor Bracket	M-Drive Brackets Available			
	NEMA Motor	Footed?	IEC B-14 Motor	Footed?
G495	56C, 143/5TC, 182/4TC	No ③	80, 90	No ③
GG495	56C, 143/5TC, 182/4TC	No ③	80, 90	No
H495	56C, 143/5TC, 182/4TC, 213/5TC	No ③	90, 100/112, 132	Yes
HJ495	56C, 143/5TC, 182/4TC, 213/5TC	No ③	90, 100/112, 132	Yes
HL495	56C, 143/5TC, 182/4TC, 213/5TC	No ③	90, 100/112, 132	Yes
AS495	182/4TC, 213/5TC, 254/6TC, 284/6TC	Yes	132, 160	Yes
AK495	182/4TC, 213/5TC, 254/6TC, 284/6TC	Yes	132, 160	Yes
AL495	182/4TC, 213/5TC, 254/6TC, 284/6TC	Yes	132, 160	Yes
① KE4195	213/5TC, 254/6TC, 284/6TC	Yes	132, 160	Yes
① KKE4195	213/5TC, 254/6TC, 284/6TC	Yes	132, 160	Yes
① LQE4195	324/6TC	Yes	160/180 ②	Yes
① LSE4195	324/6TC	Yes	160/180 ②	Yes

① 495 models require a motor mount bracket, they do not have a mounting foot.
KE, KKE, LQE, LSE 4195 models have both mounting flange for motor bracket and a mounting foot.

② Only available as B5.

③ Requires footed motor.

Direct Drive (D-Drive)

Pump and motor mounted on a base with coupling and coupling guard.

Sizes: G - LSE4195

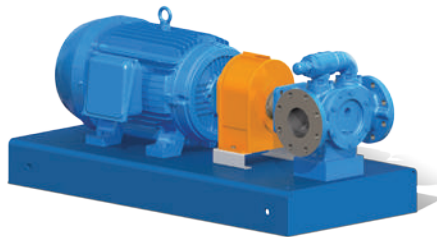

Reducer Drive (R-Drive)

Pump, Viking C-reducer and motor mounted on a base with couplings and coupling guards.

Sizes: Q & QS4195

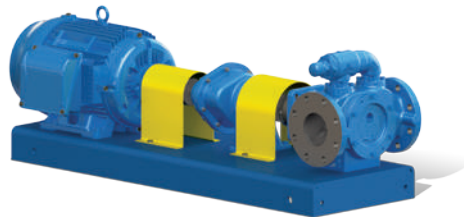

Section	1441
Page	1441.6
Issue	B

**MOTOR SPEED PRODUCT LINE:
CAST IRON PUMPS
SERIES 495, 4195**

DIMENSIONS – G, GG, H, HJ, HL SIZES (495)

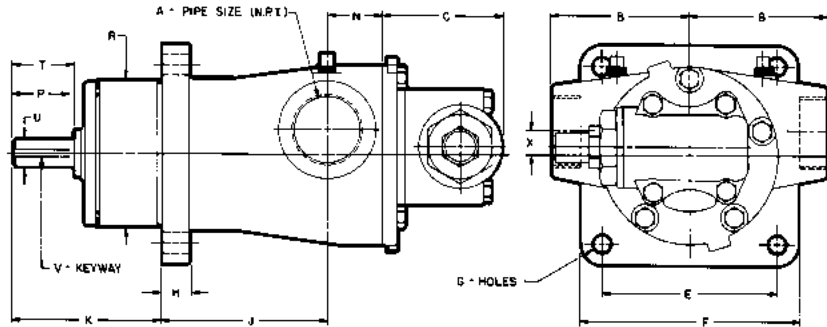

Model Number	A (in)		B	C	E	F	G	H	J	K	N	P	R	T	U (in)	V (in)	X
G495 GG495	1	in	2.75	2.66	3.00	4.00	0.41	0.50	3.44	2.81	1.12	0.94	2.88	1.12	0.50	FLAT	0.62
		mm	70	67	76	102	10	13	87	71	29	24	73	29			16
H495 HJ495 HL495	1½	in	3.75	3.28	4.75	5.88	0.56	0.75	4.50	4.00	1.50	1.50	3.88	1.62	0.75	.19 x .09	0.62
		mm	95	83	121	149	14	19	114	102	38	38	98	41			16

DIMENSIONS – AS, AK, AL SIZES (495)

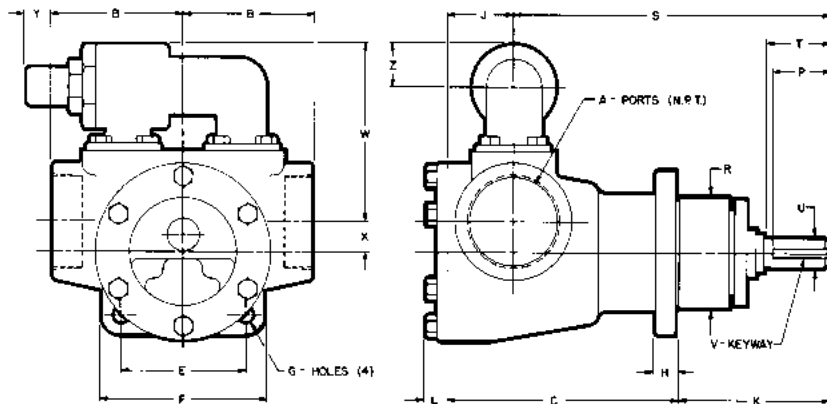

Model Number	A (in)		B	C	E	F	G	H	J	K	L	P	R	S	T	U (in)	V (in)	W	X	Y	Z
AS495 AK495	2½	in	5.00	8.38	4.75	6.25	0.56	0.75	2.00	5.75	0.75	2.25	4.25	12.12	2.50	1.00	.25 x .12	7.00	1.12	1.00	1.72
		mm	127	213	121	159	14	19	51	146	22	57	108	308	64			178	29	25	40
AL495	3	in	5.00	8.88	4.75	6.25	0.56	0.75	2.50	5.75	0.75	2.25	4.25	12.12	2.50	1.00	.25 x .12	7.00	1.12	1.00	1.72
		mm	127	225	121	159	14	19	64	146	22	57	108	308	64			178	29	25	40

These dimensions are average and not for construction purposes. Certified prints on request.

MOTOR SPEED PRODUCT LINE: CAST IRON PUMPS

SERIES 495, 4195

Section	1441
Page	1441.7
Issue	B

DIMENSIONS – G, GG, H, HJ, HL SIZES (4195)

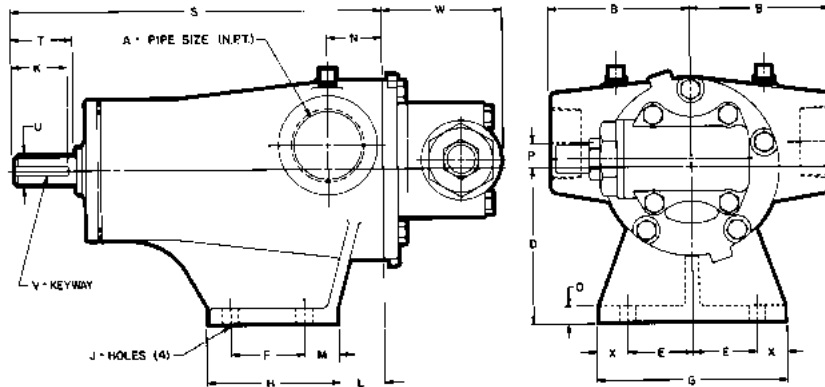

Model Number	A (in)		B	D	E	F	G	H	J	K	L	M	N	O	P	S	T	U (in)	V (in)	W	X
G495 GG495	1	in	2.75	2.75	1.62	1.31	4.00	2.44	0.34	0.94	0.03	0.66	1.12	0.31	0.62	7.31	1.12	0.50	FLAT	2.66	0.38
		mm	70	70	41	33	102	62	9	24	1	17	29	8	16	186	29			67	10
H495 HJ495 HL495	1½	in	3.75	4.12	1.75	2.00	5.00	3.50	0.41	1.50	1.25	0.88	1.50	0.44	0.62	10.00	1.62	0.75	.19 x .09	3.28	0.75
		mm	95	105	44	51	127	89	10	38	32	22	38	11	16	254	41			83	19

DIMENSIONS – AS, AK, AL SIZES (4195)

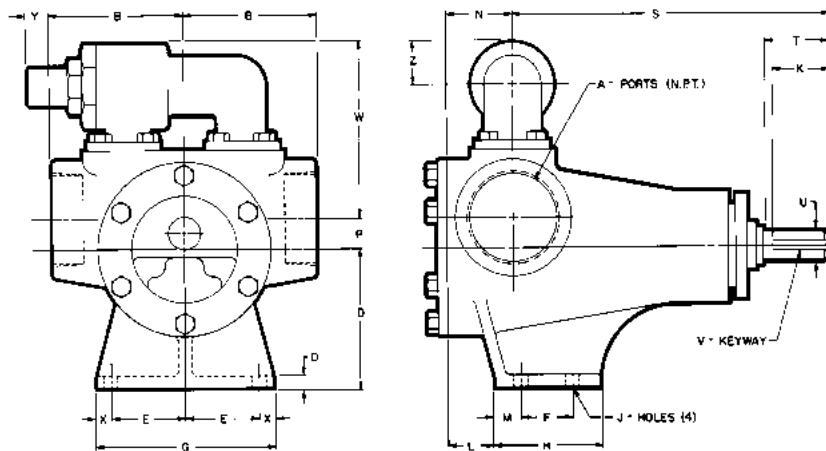

Model Number	A (in)		B	D	E	F	G	H	J	K	L	M	N	O	P	S	T	U (in)	V (in)	W	X	Y	Z
AS4195 AK4195	2½	in	5.00	5.25	2.88	2.00	6.75	4.00	0.41	2.25	1.25	1.00	2.00	0.44	1.12	12.12	2.50	1.00	.25 x .12	7.00	0.50	1.00	1.72
		mm	127	133	73	51	171	102	10	57	32	25	51	11	29	308	60			178	13	25	40
AL4195	3	in	5.00	5.25	2.88	2.00	6.75	4.00	0.41	2.25	1.75	1.00	2.50	0.44	1.12	12.12	2.50	1.00	.25 x .12	7.00	0.50	1.00	1.72
		mm	127	133	73	51	171	102	10	57	44	25	64	11	29	308	60			178	13	25	40

These dimensions are average and not for construction purposes. Certified prints on request.

Section	1441
Page	1441.8
Issue	B

**MOTOR SPEED PRODUCT LINE:
CAST IRON PUMPS
SERIES 495, 4195**

DIMENSIONS – KE, KKE, LQE, LSE SIZES (4195)

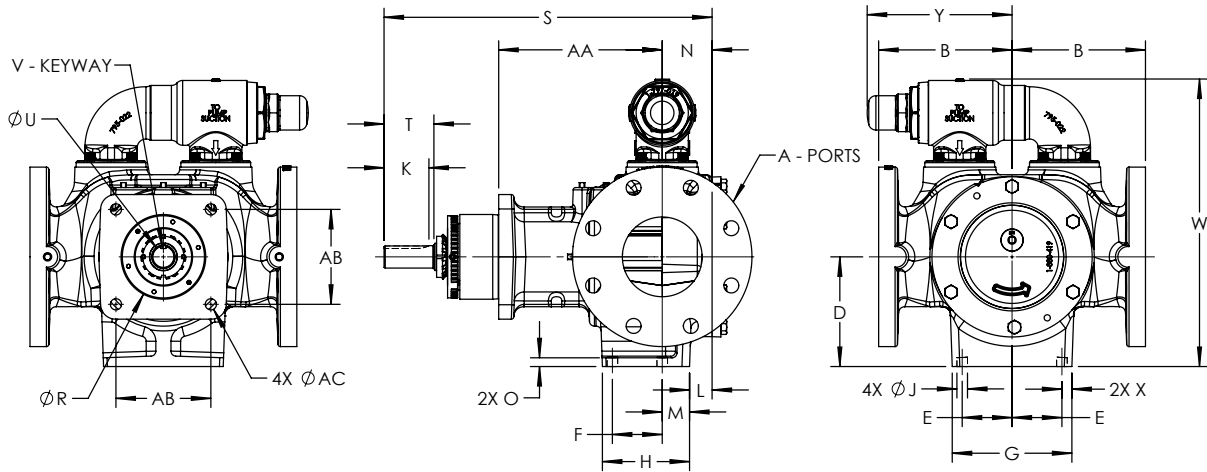

Model Number		A*	B	D	E	F	G	H	J	K	L	M	N	O	R	S	T	U (in)	V (in)	W	X	Y	AA	AB	AC
KE4195	in	4	6.69	5.50	2.50	2.50	6.00	4.37	0.53	2.25	1.13	1.37	2.50	0.44	4.25	16.45	2.50	1.13	.25 X .12	14.42	0.50	7.26	8.20	4.76	0.56
KKE4195	mm	100	170	140	64	64	152	111	14	57	29	35	64	11	108	418	64			366	13	184	208	121	14
LQE4195	in	4	8.50	7.00	3.00	2.75	7.24	5.00	0.53	3.25	1.50	1.25	2.75	0.51	5.25	19.03	3.50	1.44	.38 X .19	19.88	0.62	9.66	9.88	4.76	0.56
LSE4195	mm	100	216	178	76	70	184	127	14	83	38	32	70	13	133	483	89			505	16	245	251	121	14

* Inch dimensions for Class 125 ANSI flanged ports, mm dimensions for DIN PN-16 flanged ports.

DIMENSIONS – Q, QS SIZES (4195)

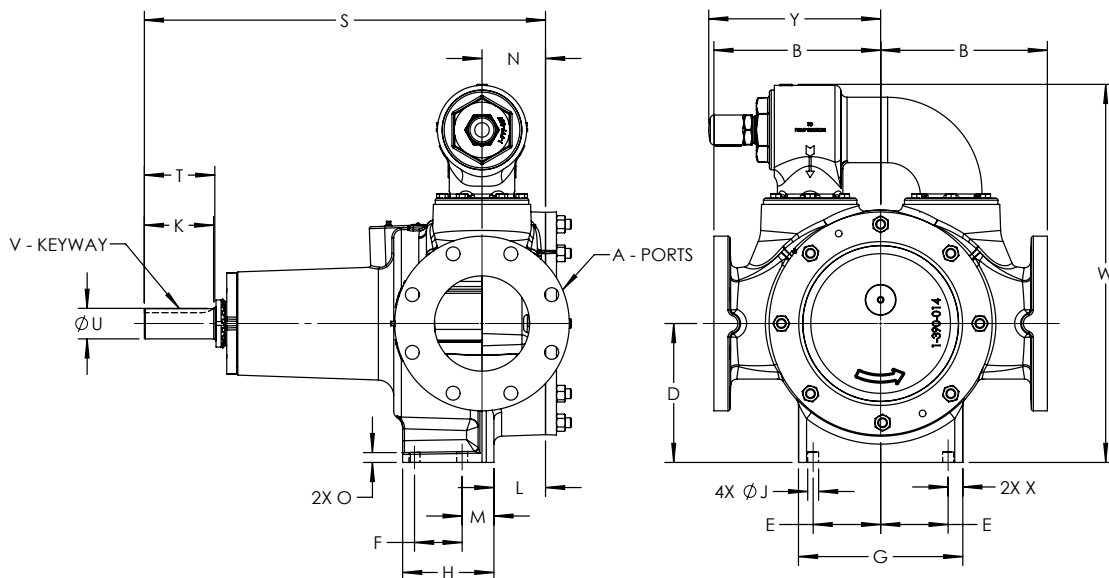

Model Number		A*	B	D	E	F	G	H	J	K	L	M	N	O	S	T	U (in)	V (in)	W	X	Y
Q4195	in	6	10.50	8.75	4.25	3.00	10.35	5.75	0.69	4.36	3.25	2.00	4.00	0.62	25.26	4.44	1.94	.50 X .25	7.00	1.00	1.72
QS4195	mm	150	267	222	108	76	263	146	18	111	83	51	102	16	642	113			178	25	40

* Inch dimensions for Class 125 ANSI flanged ports, mm dimensions for DIN PN-16 flanged ports.

These dimensions are average and not for construction purposes. Certified prints on request.

MOTOR SPEED PRODUCT LINE: CAST IRON PUMPS

SERIES 495, 4195

Section	1441
Page	1441.9
Issue	B

DIMENSIONS – G, GG, H, HJ, HL SIZES – M DRIVE (495)

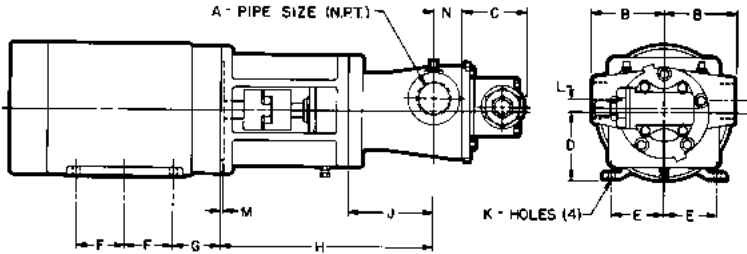

NOTE: Jaw type coupling with straight jaws recommended to facilitate assembly of motor and pump to bracket.

COUPLING IS GUARDED WITH PLATES OVER SIDE OPENINGS ON MOUNTING BRACKET.

MODEL	A	B	C	J	L	M	N	MOTOR FRAME	D	E	F	G	H	K	
G495 GG495	1	in	2.75	2.66	3.44	.62	.19	1.12	NEMA 56C	3.50	2.44	1.50	2.56	8.88	.34
		mm	70	67	87	16	5	29		89	62	38	65	225	9
	1	in	2.75	2.66	3.44	.62	.19	1.12	NEMA 143TC	3.50	2.75	2.00	2.88	8.88	.34
		mm	70	67	87	16	5	29		89	70	51	73	225	9
	1	in	2.75	2.66	3.44	.62	.19	1.12	NEMA 145TC	3.50	2.75	2.50	2.88	8.88	.34
		mm	70	67	87	16	5	29		89	70	64	73	225	9
	1	in	2.75	2.66	3.44	.62	.19	1.12	NEMA 182TC	4.50	3.75	2.25	3.38	9.56	.41
		mm	70	67	87	16	5	29		144	95	57	86	243	10
1	in	2.75	2.66	3.44	.62	.19	1.12	NEMA 184TC	4.50	3.75	2.75	3.38	9.56	.41	
	mm	70	67	87	16	5	29		114	95	70	86	243	10	
G495 GG495	1	in	2.75	2.66	3.44	0.62	0.19	1.12	IEC 80	3.15	2.46	1.97	1.97	4.38	0.39
		mm	69.9	67.6	87.4	15.7	4.8	28.4		80.0	62.5	50.0	50.0	111.3	10.0
	1	in	2.75	2.66	3.44	0.62	0.19	1.12	IEC 90	3.54	2.76	1.97	2.21	8.71	0.39
		mm	69.9	67.6	87.4	15.7	4.8	28.4		90.0	70.0	50.0	56.0	221.2	10.0

MODEL	A	B	C	J	L	M	N	MOTOR FRAME	D	E	F	G	H	K	
H495 HJ495 HL495	1	in	3.75	3.28	4.50	.62	.19	1.50	NEMA 56C	3.50	2.44	1.50	2.56	11.12	.34
		mm	95	83	114	16	5	38		89	62	38	65	283	9
	1	in	3.75	3.28	4.50	.62	.19	1.50	NEMA 143TC	3.50	2.75	2.00	2.88	11.12	.34
		mm	95	83	114	16	5	38		89	70	51	73	283	9
	1	in	3.75	3.28	4.50	.62	.19	1.50	NEMA 145TC	3.50	2.75	2.50	2.88	11.12	.34
		mm	95	83	114	16	5	38		89	70	64	73	283	9
	1 1/2	in	3.75	3.28	4.50	.62	.19	1.50	NEMA 182TC	4.50	3.75	2.25	3.38	11.81	.41
		mm	95	83	114	16	5	38		144	95	57	86	300	10
1	in	3.75	3.28	4.50	.62	.19	1.50	NEMA 184TC	4.50	3.75	2.75	3.38	11.81	.41	
	mm	95	83	114	16	5	38		114	95	70	86	300	10	
1	in	3.75	3.28	4.50	.62	.19	1.50	NEMA 213TC	5.25	4.25	2.75	4.25	12.56	.41	
	mm	95	83	114	16	5	38		133	108	70	108	319	10	
1	in	3.75	3.28	4.50	.62	.19	1.50	NEMA 215TC	5.25	4.25	3.50	4.25	12.56	.41	
	mm	95	83	114	16	5	38		133	108	89	108	319	10	

DIMENSIONS – H, HJ, HL SIZES – IEC FRAME M DRIVE (495)

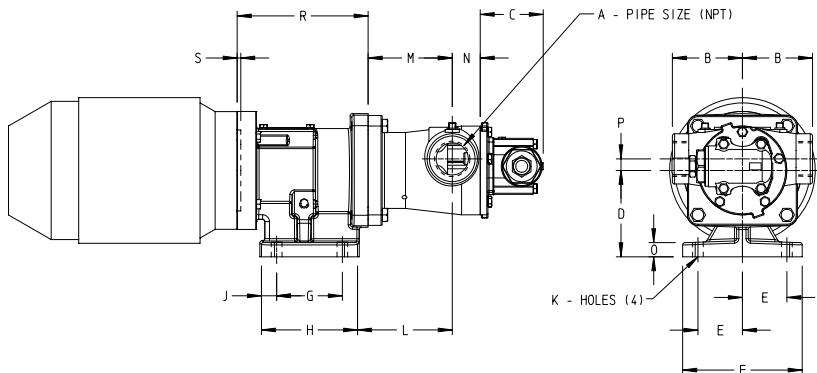

Brackets are designed for IEC motors with B14 mounting face.

NOTE: Jaw type coupling with straight jaws recommended to facilitate assembly of motor and pump to bracket.

COUPLING IS GUARDED WITH PLATES OVER SIDE OPENINGS ON MOUNTING BRACKET.

MODEL	A (in)	B	C	M	N	P	MOTOR FRAME	D	E	F	G	H	J	K	L	O	R	S	
H495	in	1 1/2	3.75	3.28	4.50	1.50	0.62	IEC 90	4.62	2.38	6.40	3.52	5.14	0.81	0.57	4.92	0.75	6.61	0.19
	mm		95	83	114	38	16			117	61	163	89	131	21	15	125	19	168
HJ495	in		3.75	3.28	4.50	1.50	0.62	IEC 100/112	4.62	2.38	6.40	3.52	5.14	0.81	0.57	4.98	0.75	7.01	0.19
	mm		95	83	114	38	16			117	61	163	89	131	21	15	129	19	178
HL495	in	3.75	3.28	4.50	1.50	0.62	IEC 132	5.32	2.95	7.48	4.50	6.09	0.80	0.57	5.11	0.75	8.16	0.25	
	mm	95	83	114	38	16			135	75	190	114	155	20	15	130	19	207	6

These dimensions are average and not for construction purposes. Certified prints on request.

Section	1441
Page	1441.10
Issue	B

**MOTOR SPEED PRODUCT LINE:
CAST IRON PUMPS
SERIES 495, 4195**

DIMENSIONS – AS, AK, AL SIZES – M DRIVE (495)

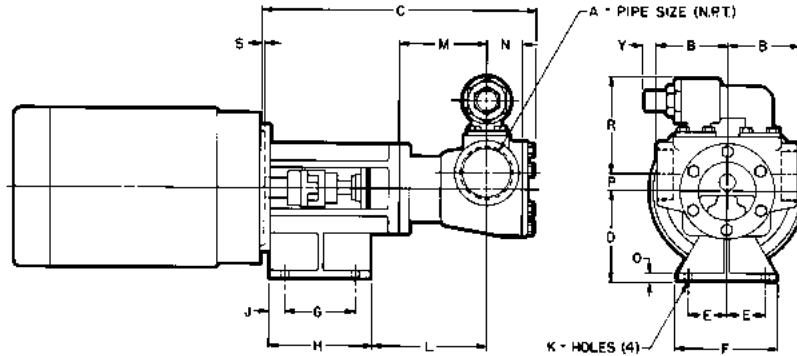

Model Number	Motor Frame	A (in)		B	C	D	E	F	G	H	J	K	L	M	N	O	P	R	S	Y
AS495 AK495	NEMA ①	2½	In	5.00	① 19.06	6.25	2.75	7.00	5.00	7.00	1.00	0.56	① 8.44	6.38	2.00	0.50	1.12	7.00	0.19	1.00
			mm	127	① 484	159	70	178	127	178	25	14	① 214	162	51	13	29	178	5	25
	IEC 132	2½	In	5.00	18.16	6.25	2.75	7.00	5.00	7.24	1.12	0.56	7.75	6.38	2.00	0.50	1.12	7.12	0.25	6.00
			mm	127	461	159	70	178	127	184	28	14	197	162	51	13	28	181	6	152
	IEC 160	2½	In	5.00	19.58	6.50	2.75	7.50	6.00	8.26	1.13	0.56	7.75	6.38	2.00	0.62	1.12	7.12	0.25	6.00
			mm	127	497	165	70	191	152	210	29	14	197	162	51	16	28	181	6	152
AL495	NEMA ①	3	In	5.00	① 19.56	6.25	2.75	7.00	5.00	7.00	1.00	0.56	① 8.44	6.38	2.50	0.50	1.12	7.00	0.19	1.00
			mm	127	① 497	159	70	178	127	178	25	14	① 214	162	64	13	29	178	5	25
	IEC 132	3	In	5.00	18.66	6.25	2.75	7.00	5.00	7.24	1.12	0.56	7.75	6.38	2.50	0.50	1.12	7.12	0.25	6.00
			mm	127	20	159	70	178	127	184	28	14	197	162	64	13	28	181	6	152
	IEC 160	3	In	5.00	20.08	6.50	2.75	7.50	6.00	8.26	1.13	0.56	7.75	6.38	2.50	0.62	1.12	7.12	0.25	6.00
			mm	127	510	165	70	191	152	210	29	14	197	162	64	16	28	181	6	152

① Dimensions are correct for 182TC through 215TC motors. For 254TC/256TC motors, add .88" to the dimensions shown.

NOTE: Jaw type coupling with straight jaws recommended to facilitate assembly of motor and pump to bracket.

COUPLING IS GUARDED WITH PLATES OVER SIDE OPENINGS ON MOUNTING BRACKET.

These dimensions are average and not for construction purposes. Certified prints on request.

MOTOR SPEED PRODUCT LINE: CAST IRON PUMPS

SERIES 495, 4195

Section	1441
Page	1441.11
Issue	B

DIMENSIONS – KE, KKE, LQE, LSE SIZES – PUMP, M DRIVE, MOTOR (4195)

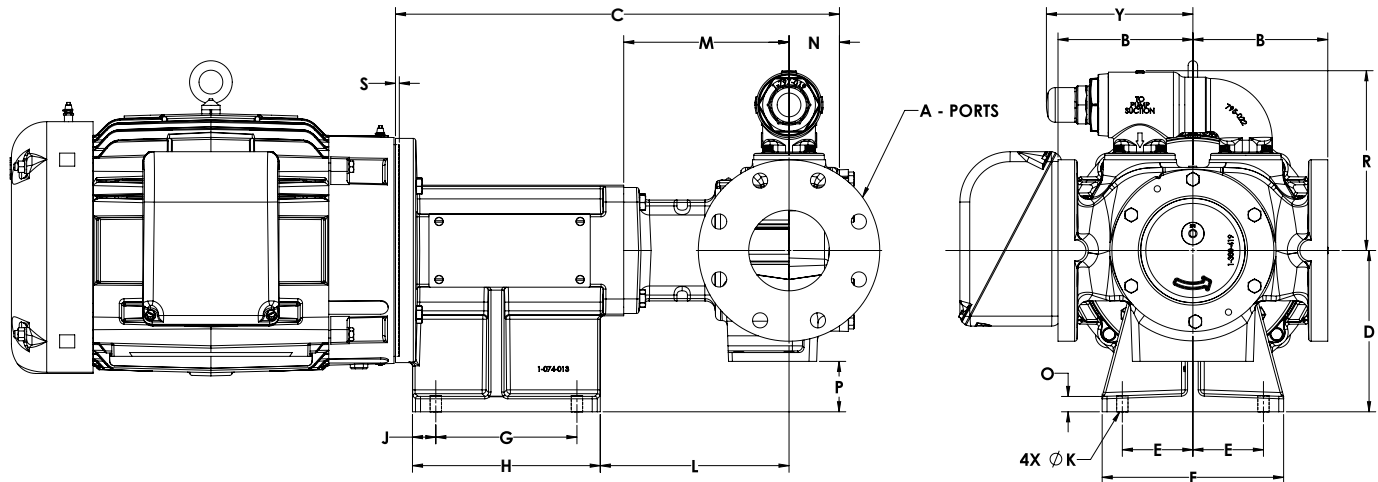

Model Number	Motor	A*		B	C	D	E	F	G	H	J	K	L	M	N	O	P	R	S	Y
KE4195 KKE4195	NEMA 213/215	4	in	6.69	20.51	6.25	2.75	7.00	5.00	7.24	1.12	0.56	10.14	8.20	2.50	0.50	0.75	8.92	0.19	7.26
		100	mm	169.9	521.0	158.8	69.9	177.8	127.0	183.9	28.4	14.2	257.6	208.3	63.5	12.7	19.1	226.6	4.8	184.4
	NEMA 254/256	4	in	6.69	21.39	6.25	2.75	7.00	5.00	7.24	1.12	0.56	11.02	8.20	2.50	0.50	0.75	8.92	0.19	7.26
		100	mm	169.9	543.3	158.8	69.9	177.8	127.0	183.9	28.4	14.2	279.9	208.3	63.5	12.7	19.1	226.6	4.8	184.4
	NEMA 284/286	4	in	6.69	22.02	8.00	3.50	9.00	7.00	9.31	1.16	0.56	9.36	8.20	2.50	0.76	2.50	8.92	0.19	7.26
		100	mm	169.9	559.3	203.2	88.9	228.6	177.8	236.5	29.5	14.2	237.7	208.3	63.5	19.3	63.5	226.6	4.8	184.4
IEC 132	4	in	6.69	18.08	6.25	2.75	7.00	5.00	7.24	1.12	0.56	9.58	8.20	2.50	0.50	0.75	8.92	0.25	7.26	
	100	mm	169.9	459.2	158.8	69.9	177.8	127.0	183.9	28.4	14.2	243.3	208.3	63.5	12.7	19.1	226.6	6.4	184.4	
IEC 160	4	in	6.69	19.40	6.50	2.75	7.50	6.00	8.26	1.13	0.56	9.57	8.20	2.50	0.62	1.00	8.92	0.25	7.26	
	100	mm	169.9	492.8	165.1	69.9	190.5	152.4	209.8	28.7	14.2	243.1	208.3	63.5	15.7	25.4	226.6	6.4	184.4	
LQE4195 LSE4195	NEMA 324/326	4	in	8.50	25.3	8.25	3.88	10.00	7.25	9.85	1.30	0.88	10.71	9.88	2.75	0.75	1.25	12.88	0.19	9.66
		100	mm	215.9	642.6	209.6	98.6	254.0	184.2	250.2	33.0	22.4	272.0	251.0	69.9	19.1	31.8	327.2	4.8	243.7
	IEC 160	4	in	8.50	21.63	7.50	3.25	9.00	7.25	9.81	1.28	0.88	10.34	9.88	2.75	0.75	0.50	12.88	0.25	9.66
		100	mm	215.9	549.4	190.5	82.6	228.6	184.2	249.2	32.5	22.4	262.6	251.0	69.9	19.1	12.7	327.2	6.4	243.7
	IEC 180	4	in	8.50	21.63	7.50	3.25	9.00	7.25	9.81	1.28	0.88	10.34	9.88	2.75	0.75	0.50	12.88	0.25	9.66
		100	mm	215.9	549.4	190.5	82.6	228.6	184.2	249.2	32.5	22.4	262.6	251.0	69.9	19.1	12.7	327.2	6.4	243.7

* Inch dimensions for Class 125 ANSI flanged ports, mm dimensions for DIN PN-16 flanged ports.

These dimensions are average and not for construction purposes. Certified prints on request.

Section	1441
Page	1441.12
Issue	B

**MOTOR SPEED PRODUCT LINE:
CAST IRON PUMPS
SERIES 495, 4195**

DIMENSIONS – G, GG, H, HJ, HL, AS, AK, AL SIZES – D DRIVE (4195)

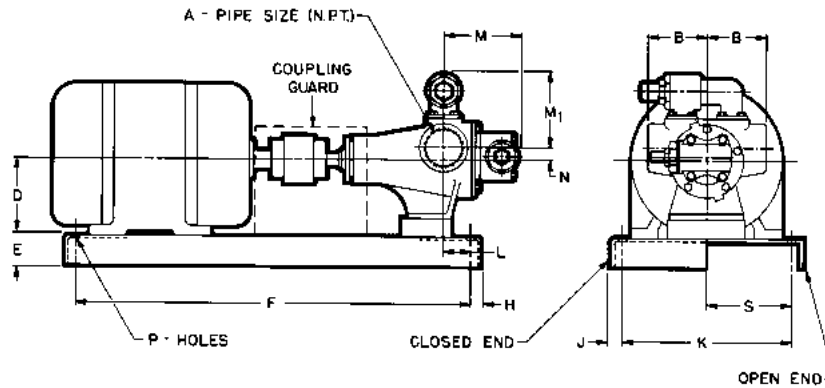

Model	Motor	A (in)		B	D	E	F	H	J	K	L	M	M ₁	N	P	S
G4195 GG4195	NEMA 56	1	in	2.75	3.50	1.50	20.50	0.75	0.75	8.50	0.38	3.81	—	0.63	0.63	4.25
			mm	70	89	38	521	19	19	216	10	97		16	16	108
	NEMA 143/145	1	in	2.75	3.50	1.50	20.50	0.75	0.75	8.50	0.38	3.81		0.63	0.63	4.25
			mm	70	89	38	521	19	19	216	10	97		16	16	108
	NEMA 182/184	1	in	2.75	4.50	1.50	20.50	0.75	0.75	8.50	0.38	3.81		0.63	0.63	4.25
			mm	70	114	38	521	19	19	216	10	97		16	16	108
	NEMA 213/215	1	in	2.75	5.25	2.94	29.00	1.00	1.50	9.00	1.90	3.81		0.63	0.63	4.50
			mm	70	133	75	737	25	38	229	48	97		16	16	114
H4195 HJ4195 HL4195	NEMA 56	1½	in	3.75	4.12	1.50	20.50	0.75	0.75	8.50	—	4.78	—	0.62	0.63	4.25
			mm	95	105	38	521	19	19	216	—	121		16	16	108
	NEMA 143/145	1½	in	3.75	4.12	1.50	20.50	0.75	0.75	8.50	—	4.78		0.62	0.63	4.25
			mm	95	105	38	521	19	19	216	—	121		16	16	108
	NEMA 182/184	1½	in	3.75	4.50	2.94	29.00	1.00	1.50	9.00	0.25	4.78		0.62	0.63	4.50
			mm	95	114	75	737	25	38	229	6	121		16	16	114
	NEMA 213/215	1½	in	3.75	5.25	2.94	29.00	1.00	1.50	9.00	0.25	4.78		0.62	0.63	4.50
			mm	95	133	75	737	25	38	229	6	121		16	16	114
	NEMA 254/256	1½	in	3.75	6.50	3.25	28.75	1.00	1.00	17.00	—	4.78		0.62	0.63	8.50
			mm	95	165	83	730	25	25	432	—	121		16	16	216
AS4195 AK4195 AL4195 *	NEMA 143/145T	2½	in	5.00	5.25	2.94	29.00	1.00	1.50	9.00	1.75	—	6.97	1.12	0.63	4.50
			mm	127	133	75	737	25	38	229	45		177	28	16	114
	NEMA 182/184	2½	in	5.00	5.25	2.94	29.00	1.00	1.50	9.00	—		6.97	1.12	0.63	4.50
			mm	127	133	75	737	25	38	229	—		177	28	16	114
	NEMA 213/215	2½	in	5.00	5.25	2.94	34.00	1.00	1.50	9.00	—		6.97	1.12	0.63	4.50
			mm	127	133	75	864	25	38	229	—		177	28	16	114
	NEMA 254/256	2½	in	5.00	6.25	4.00	39.00	1.38	1.38	16.00	3.75		6.97	1.12	0.63	8.00
			mm	127	159	102	991	35	35	406	95		177	28	16	203
	NEMA 284/286	2½	in	5.00	7.00	4.00	39.00	1.38	1.38	16.00	1.75		6.97	1.12	0.63	8.00
			mm	127	178	102	991	35	35	406	45		177	28	16	203

* 3" port on AL4195D.

These dimensions are average and not for construction purposes. Certified prints on request.

MOTOR SPEED PRODUCT LINE: CAST IRON PUMPS

SERIES 495, 4195

Section	1441
Page	1441.13
Issue	B

DIMENSIONS – KE, KKE, LQE, LSE, Q SIZES – D DRIVE (4195)

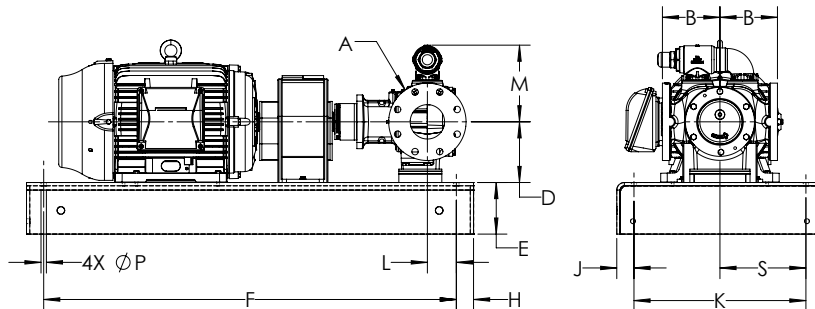

Model	Motor		A*	B	D	E	F	H	J	K	L	M	P	S
KE4195 KKE4195	NEMA 213/215	in	4	6.69	5.50	4.00	37.75	2.00	2.00	14.75	3.37	8.92	0.63	7.38
		mm	100	169.9	139.7	101.6	958.9	50.8	50.8	374.7	85.6	226.6	16.0	187.3
	NEMA 254/256	in	4	6.69	6.25	6.00	48.00	2.00	2.00	20.00	3.37	8.92	0.63	10.00
		mm	100	169.9	158.8	152.4	1219.2	50.8	50.8	508.0	85.6	226.6	16.0	254.0
	NEMA 284/286	in	4	6.69	7.00	6.00	48.00	2.00	2.00	20.00	3.37	8.92	0.63	10.00
		mm	100	169.9	177.8	152.4	1219.2	50.8	50.8	508.0	85.6	226.6	16.0	254.0
LQE4195 LSE4195	NEMA 284/286	in	4	6.69	7.31	6.00	48.00	2.00	2.00	20.00	3.25	12.88	0.63	10.00
		mm	100	169.9	185.7	152.4	1219.2	50.8	50.8	508.0	82.6	327.2	15.9	254.0
	NEMA 324/326	in	4	6.69	8.06	6.00	58.50	2.00	2.00	18.75	3.25	12.88	0.63	9.38
		mm	100	169.9	204.7	152.4	1485.9	50.8	50.8	476.3	82.6	327.2	15.9	238.1
	NEMA 364/365	in	4	6.69	9.06	6.00	58.50	2.00	2.00	18.75	3.25	12.88	0.63	9.38
		mm	100	169.9	230.1	152.4	1485.9	50.8	50.8	476.3	82.6	327.2	15.9	238.1
Q4195	IEC 280	in	6	10.50	11.37	6.00	68.00	2.00	2.00	32.00	1.00	15.06	0.88	16.00
		mm	150	266.7	288.8	152.4	1727.2	50.8	50.8	812.8	25.4	382.5	22.4	406.4

* Inch dimensions for Class 125 ANSI flanged ports, mm dimensions for DIN PN-16 flanged ports.

DIMENSIONS – Q, QS SIZES – R DRIVE (4195)

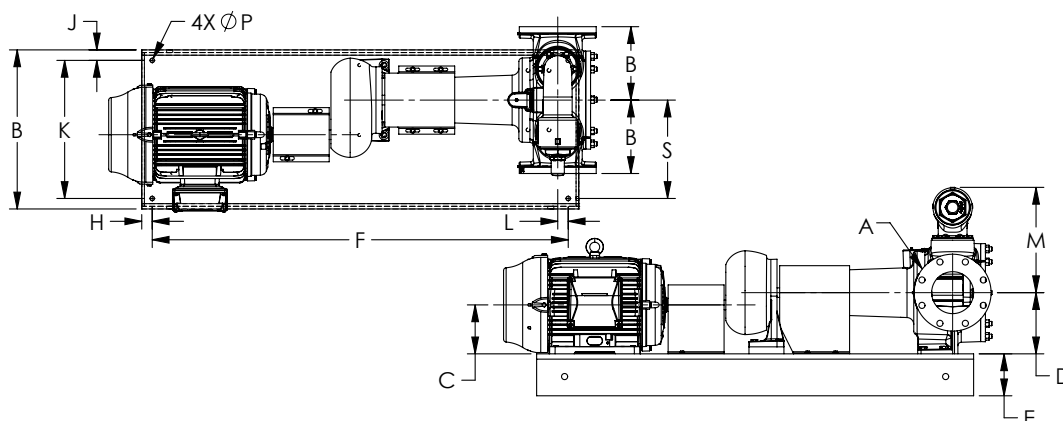

Model	Motor		A*	B	C	D	E	F	H	J	K	L	M	P	S
Q4195 QS4195	NEMA 254/256	in	6.00	10.50	6.25	8.75	6.00	59.50	1.50	1.50	19.75	1.50	15.06	0.63	14.07
		mm	150	266.7	158.8	222.3	152.4	1511.3	38.1	38.1	501.7	38.1	382.5	15.9	357.4
	NEMA 284/286	in	6.00	10.50	7.00	8.75	6.00	59.50	1.50	1.50	19.75	1.50	15.06	0.63	14.07
		mm	150	266.7	177.8	222.3	152.4	1511.3	38.1	38.1	501.7	38.1	382.5	15.9	357.4
	NEMA 324/326	in	6.00	10.50	8.00	8.75	6.00	68.00	2.00	2.00	20.00	1.00	15.06	0.63	14.81
		mm	150	266.7	203.2	222.3	152.4	1727.2	50.8	50.8	508.0	25.4	382.5	15.9	376.2

* Inch dimensions for Class 125 ANSI flanged ports, mm dimensions for DIN PN-16 flanged ports.

These dimensions are average and not for construction purposes. Certified prints on request.

Section	1441
Page	1441.14
Issue	B

MOTOR SPEED PRODUCT LINE: CAST IRON PUMPS SERIES 495, 4195

NPSH REQUIRED

Printed performance curves are not available.

Performance curves can be electronically generated with the Viking Pump Selector Program on vikingpump.com.

NPSHR data is not available on the pump selector.

Increasing the operating speed of positive displacement pumps increases the NPSH_R (Net Positive Suction Head – Required by pump) and sound levels. These are two factors that should be considered when selecting the correct pump for the application. Below are charts for the NPSH_R and sound levels of the Motor Speed Series pumps.

NPSH (Net Positive Suction Head): The NPSH_R (Net Positive Suction Head Required by the pump) is given in the table below and applies for viscosities through 750 SSU. NPSH_A (Net Positive Suction Head – Available in the system) must be greater than the NPSH_R. For a complete explanation of NPSH, see Application Data Sheet AD-19.

FOR VISCOSITIES UP TO 750 SSU – See NPSH_R table below.

NPSH_R for high viscosities can be estimated using the following method:

1. Calculate line loss for a 1 foot long pipe of a diameter matching the pump inlet port size. Use your flow rate and max viscosity.
2. Convert this value into Feet of Liquid (S.G. 1.0)
3. Add this value to the NPSH_R value in the chart below.

PUMP SIZE	PUMPS SPEED, RPM						
	520	640	780	950	1150	1450	1750
G, GG	1.6	2.2	2.6	3.1	3.9	5.6	7.6
H, HJ, HL	2	2.8	3.4	4.5	6.2	9.5	13.5
AS, AK, AL	2.8	3.9	5.5	7.7	11.2	16.8	23.3
① KE, KKE	4.4	4.9	5.7	7	8.9	12.8	17.9
① LQE, LSE	7.3	9.3	10.9	13.1	16.1	—	—
① Q, QS	6.8	9	② 12.2	—	—	—	—

Note: NPSH_R – FEET OF LIQUID (Specific Gravity 1.0), Viscosities up to 750 SSU

① These pumps utilize a directional design.

② Applies to Q pump only. QS pump max speed is 640 RPM.

EXPECTED NOMINAL SOUND LEVELS FOR MOTOR SPEED PUMPS

The sound pressure level, measured in dB(A), is a measurement of the deviation in the atmospheric pressure caused by a sound wave. The measurement is taken at a distance of approximately 1 meter from the sound source. The sound pressure levels are for the pump only using a 100 SSU liquid, at 100 PSI discharge pressure, at the speeds indicated. Background noise and ancillary equipment, such as drives and motors, in the operating environment will likely cause the actual sound pressure level to deviate from the information in the table below.

Local national laws and regulations on noise exposure in the workplace should be observed during operation.

PUMP SIZE	PUMPS SPEED, RPM						
	520	640	780	950	1150	1450	1750
G, GG	—	—	—	62	63	63	63
H, HJ, HL	—	—	—	68	70	75	80
AS, AK, AL	—	—	—	82	84	86	88
① KE, KKE	—	—	—	84	86	87	89
① LQE, LSE	—	88	89	91	93	—	—
① Q, QS	91	93	② 94	—	—	—	—

Note: NPSH_R – FEET OF LIQUID (Specific Gravity 1.0), Viscosities up to 750 SSU

① These pumps utilize a directional design.

② Applies to Q pump only. QS pump max speed is 640 RPM.