

*High-Pressure
Sanitary Centrifugal Pumps*

FM & FPH
Series

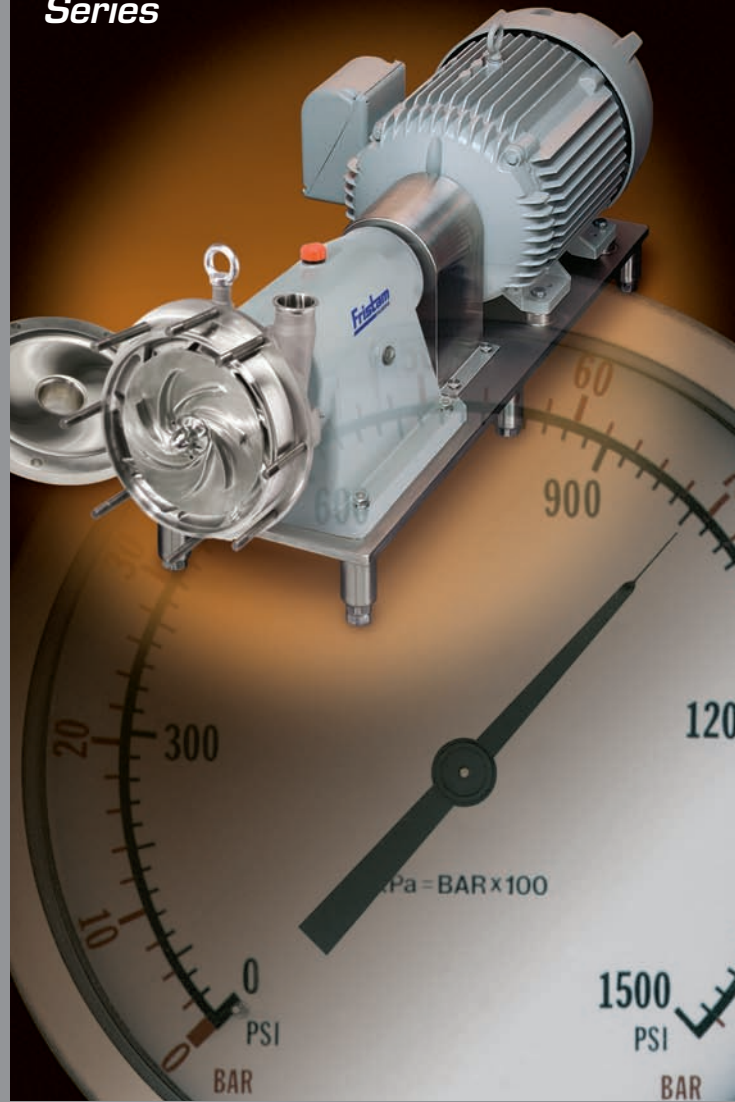

**Fristam Pumps...
Performance You've Come To Expect**

FM and FPH Series: Fristam's High-Pressure Centrifugal Pumps

Fristam is an international manufacturer of stainless steel sanitary pumps, mixers, and blenders and is known for providing innovative solutions to meet customer needs. Fristam products have served as industry benchmarks for performance, reliability, and technical superiority. Fristam's high-pressure pumps provide a cost effective solution for your high-pressure applications.

High Inlet and Discharge Pressure Capabilities

Fristam has been manufacturing high-pressure centrifugal pumps since 1981. Constructed of stainless steel to Fristam's traditional high standards, these pumps operate with inlet pressures from 600 to 1000 PSI and generate discharge pressures up to 1250 PSI while providing even, non-pulsating product flow.

Details on each of Fristam's high-pressure pumps follow on pages 2-8.

High-Pressure Pump Benefits

- Low acquisition and maintenance costs
- Even, non-pulsating product flow
- Internal seal provides long, trouble-free operation
- Discharge pressures to 1250 PSI
- Inlet pressures to 1000 PSI
- Extended life of filtration membranes
- High flow rates
- Sanitary construction
- Ability to clean-in-place (CIP)

Typical Applications

- Reverse Osmosis Systems
- Filtration
- Pressure Feed
- Recirculation

Seals

Seals are a key element of Fristam's reputation for outstanding performance. The high-pressure pumps are no exception. Our internal, double mechanical seals were designed for long service, continuous performance, and durability. These seals handle up to 1000 PSI inlet pressure.

- Standard seal materials:
Silicon Carbide vs. Silicon Carbide (except FPHP 722:
Tungsten Carbide vs. Tungsten Carbide)
- Standard secondary seal material:
Silicon Carbide vs. Carbon
- Standard elastomers: Viton®



High pressure gauge compliments of Anderson Instrument Company, Inc.

FM Multi-Stage High-Pressure Pumps

FM pumps are built with a heavy-duty bearing block assembly, mounted on a stainless steel base, complete with a coupling guard. The bearing block uses labyrinth oil seals and heavy-duty bearings. A close-coupled version (CCFM) is available for applications with space constraints.

FM pumps have become the benchmark for reverse osmosis system pumps with a non-pulsating flow and lower maintenance costs. Additionally, the FM's seal and bearing life are usually measured in years rather than months.

FM 3 Multi-Stage Pumps

FM 3 Series multi-stage pumps are available in one, two, three, or four stages, with each additional stage increasing the pump's discharge pressure capabilities. Single stage pumps are often used as re-circulation loop pumps. Two, three, and four stage pumps are typically used to produce the required system pressure for a reverse osmosis system.

The FM 3 multi-stage pump is capable of flow rates up to 300 GPM and discharge pressures up to 275 PSI. By placing pumps in series, a maximum discharge pressure of 1250 PSI can be achieved. FM 3 pumps are CIP'able and SIP'able.

FM 5 Multi-Stage Pumps

Fristam FM 5 Series multi-stage pumps offer higher flow and more pressure with easier maintenance. Designed with fewer stages, they simplify maintenance by reducing the number of mechanical parts.

The FM 5 multi-stage pump is capable of doubling the flow rate of the FM 3, up to 600 GPM. FM 5 pumps can operate at discharge pressures up to 340 PSI and inlet pressures up to 750 PSI. FM 5 pumps are CIP'able and SIP'able.

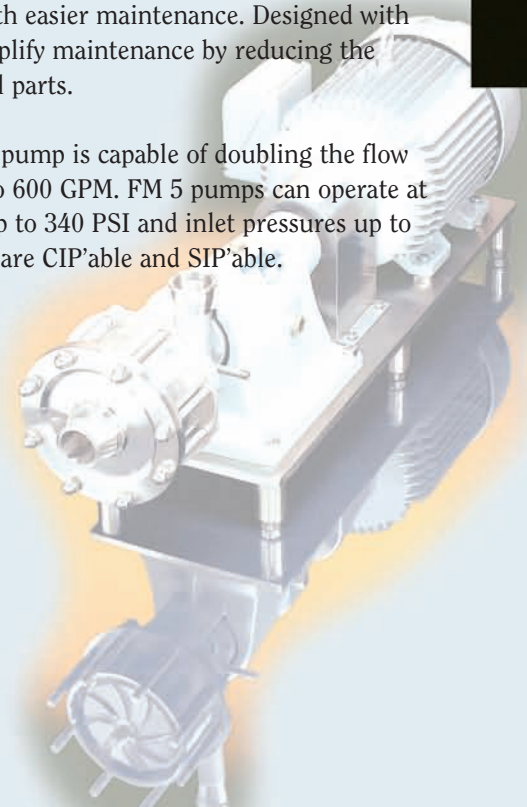
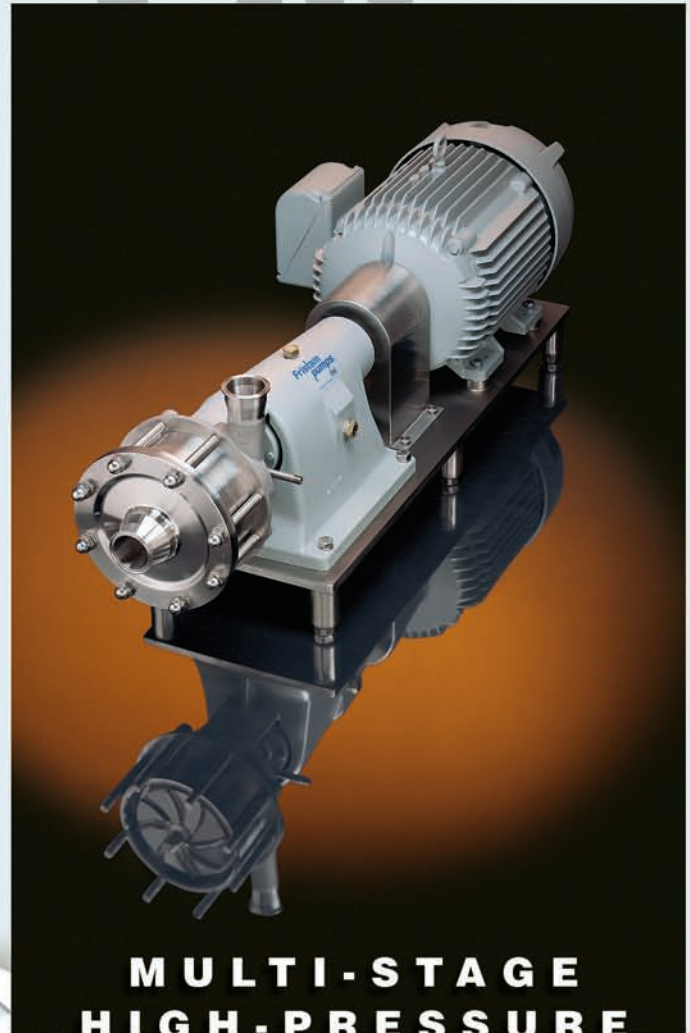

FM

FM Dimensional Drawing

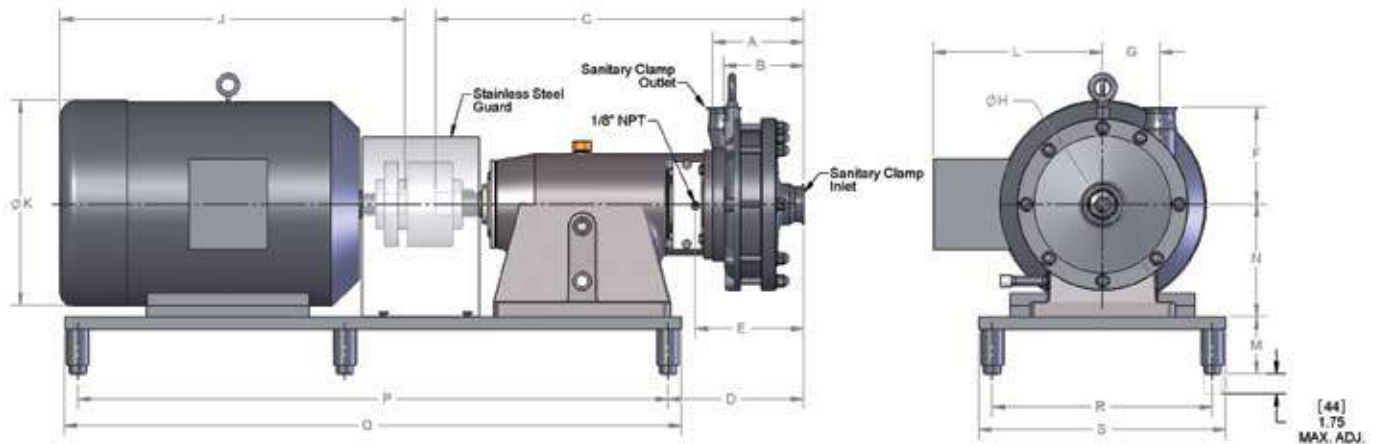

MOTOR HP 1750 RPM	MOTOR FRAME	J	K	L	M	N		P		Q		R		S	
						FM 3	FM 5	FM 3	FM 5	FM3	FM 5	FM 3	FM 5	FM 3	FM 5
7.5 HP	184T	469 (18.46")	263 (10.35")	220 (8.66")	121 (4.76")	200 (7.87")	-	1083 (42.64")	-	1143 (45.00")	-	321 (12.64")	-	381 (15.00")	-
10 HP	215T	469 (18.46")	263 (10.35")	220 (8.66")	121 (4.76")	200 (7.87")	254 (10.00")	1083 (42.64")	1108 (43.62")	1143 (45.00")	1169 (46.00")	321 (12.64")		381 (15.00")	
15 HP	215T	536 (21.10")	270 (10.63")	225 (8.86")	121 (4.76")	200 (7.87")	254 (10.00")	1083 (42.64")	1108 (43.62")	1143 (45.00")	1169 (46.00")	321 (12.64")		381 (15.00")	
20 HP	256T	580 (22.83")	270 (10.63")	225 (8.86")	121 (4.76")	200 (7.87")	254 (10.00")	1083 (42.64")	1108 (43.62")	1143 (45.00")	1169 (46.00")	321 (12.64")		381 (15.00")	
25 HP	284TS	670 (26.38")	395 (15.55")	333 (13.11")	121 (4.76")	200 (7.87")	254 (10.00")	1083 (42.64")	1108 (43.62")	1143 (45.00")	1169 (46.00")	321 (12.64")		381 (15.00")	
30 HP	286TS	670 (26.38")	395 (15.55")	333 (13.11")	121 (4.76")	200 (7.87")	254 (10.00")	1083 (42.64")	1108 (43.62")	1143 (45.00")	1169 (46.00")	321 (12.64")		381 (15.00")	
40 HP	324TS	731 (28.78")	430 (16.93")	371 (14.61")	121 (4.76")	203 (8.00")	254 (10.00")	1083 (42.64")	1108 (43.62")	1143 (45.00")	1169 (46.00")	321 (12.64")		381 (15.00")	
50 HP	326TS	731 (28.78")	430 (16.93")	371 (14.61")	121 (4.76")	203 (8.00")	254 (10.00")	1083 (42.64")	1108 (43.62")	1143 (45.00")	1169 (46.00")	321 (12.64")		381 (15.00")	
60 HP	364TS	780 (30.71")	483 (19.02")	380 (14.96")	127 (5.00")	229 (9.00")	254 (10.00")	1108 (43.62")	1336 (52.60")	1169 (46.00")	13.97 (55.00")	371 (14.64")	499 (19.65")	432 (17.00")	559 (22.00")
75 HP	365TS	780 (30.71")	483 (19.02")	380 (14.96")	127 (5.00")	229 (9.00")	254 (10.00")	1108 (43.62")	1336 (52.60")	1169 (46.00")	13.97 (55.00")	371 (14.64")	499 (19.65")	432 (17.00")	559 (22.00")
100 HP	405TS	966 (38.03")	5.16 (20.31")	457 (17.99")	127 (5.00")	254 (10.00")	254 (10.00")	-	1336 (52.60")	-	13.97 (55.00")	-	499 (19.65")	-	559 (22.00")
125 HP	444TS	1124 (44.25")	581 (22.87")	497 (19.57")	127 (5.00")	280 (11.00")	280 (11.00")	-	1336 (52.60")	-	13.97 (55.00")	-	499 (19.65")	-	559 (22.00")
150 HP	445TS	1124 (44.25")	581 (22.87")	497 (19.57")	127 (5.00")	280 (11.00")	280 (11.00")	-	1336 (52.60")	-	13.97 (55.00")	-	499 (19.65")	-	559 (22.00")

1265000422 Rev-

PUMP MODEL	INLET	OUTLET	DIMENSIONS IN MILLIMETERS (INCHES)							
			A	B	C	D	E	F	G	H
FM 312 (1 Stage)	2.5"	2.5"	141 (5.55")	116 (4.57")	746 (29.37")	239 (9.41")	200 (7.87")	211 (8.31")	90 (3.54")	286 (11.26")
FM 322 (2 Stage)	2.5"	2.5"	190 (7.48")	165 (6.50")	795 (31.30")	288 (11.34")	249 (9.80")	211 (8.31")	90 (3.54")	286 (11.26")
FM 332 (3 Stage)	2.5"	2.5"	240 (9.45")	215 (8.46")	845 (33.27")	338 (13.31")	299 (11.77")	211 (8.31")	90 (3.54")	286 (11.26")
FM 342 (4 Stage)	2.5"	2.5"	290 (11.42")	265 (10.43")	895 (35.24")	388 (15.28")	349 (13.74")	211 (8.31")	90 (3.54")	286 (11.26")
FM 512 (1 Stage)	3.0"	2.5"	158 (6.22")	133 (5.24")	786 (30.94")	259 (10.20")	197 (7.76")	219 (8.62")	133 (5.24")	286 (11.26")
FM 522 (2 Stage)	3.0"	2.5"	206 (8.11")	181 (7.13")	834 (32.83")	307 (12.09")	245 (9.65")	219 (8.62")	133 (5.24")	286 (11.26")

All dimensions are in millimeters unless otherwise specified.

Motor dimensions may vary depending on manufacturer and model requested.

Pump dimensions based on sanitary clamp fittings.



FM 3 Sanitary Pump Composite Performance Curve

Speed: 3500 rpm (60 Hertz)

Performance curves based on tests using 70°F water. A tolerance of ±5% applies to all figures.
For vacuum withdrawal applications, please contact Fristam Pumps, USA.

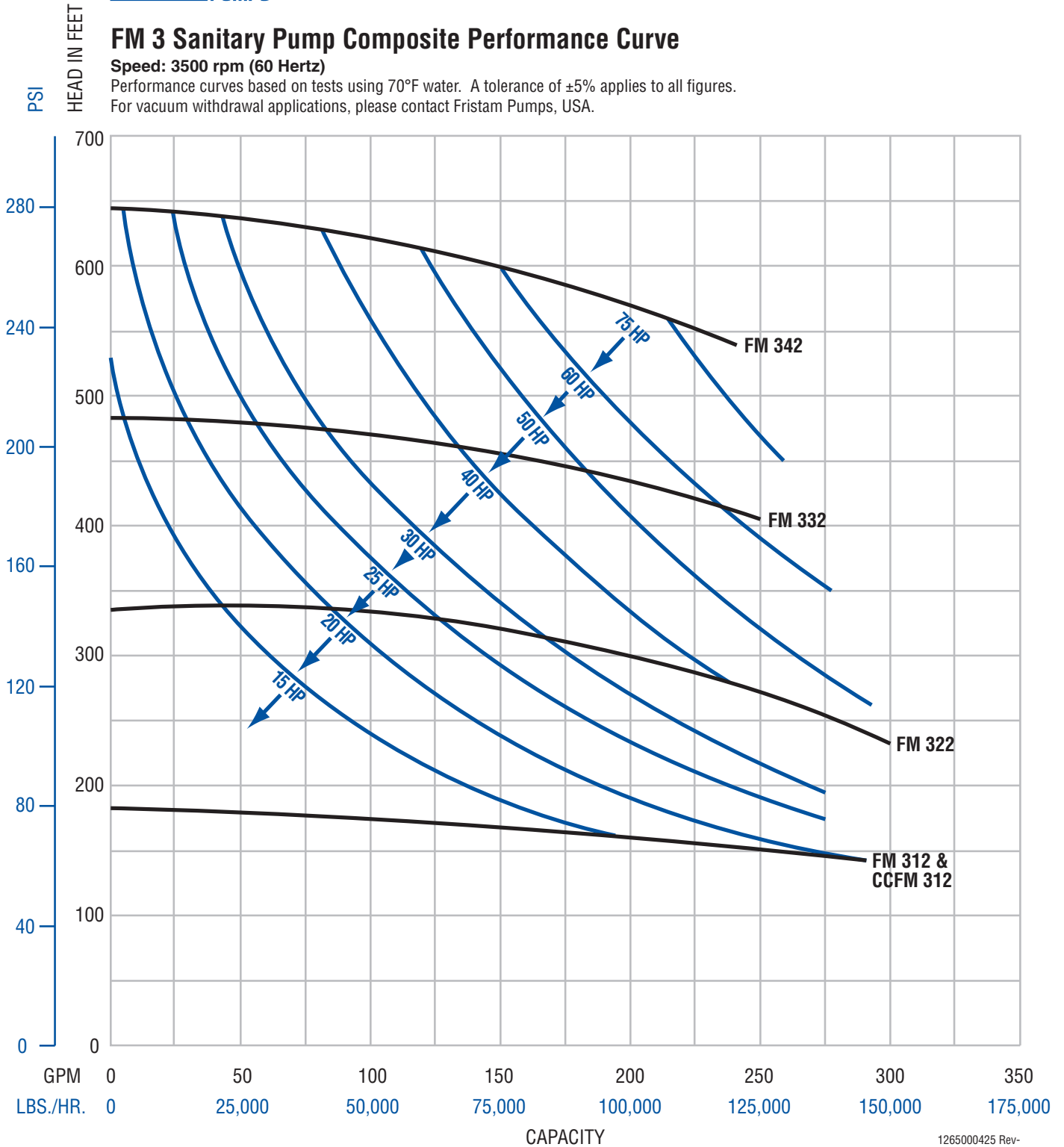

1265000425 Rev-



FM 5 Sanitary Pump Composite Performance Curve

Speed: 3500 rpm (60 Hertz)

Performance curves based on tests using 70°F water. A tolerance of ±5% applies to all figures.
For vacuum withdrawal applications, please contact Fristam Pumps, USA.

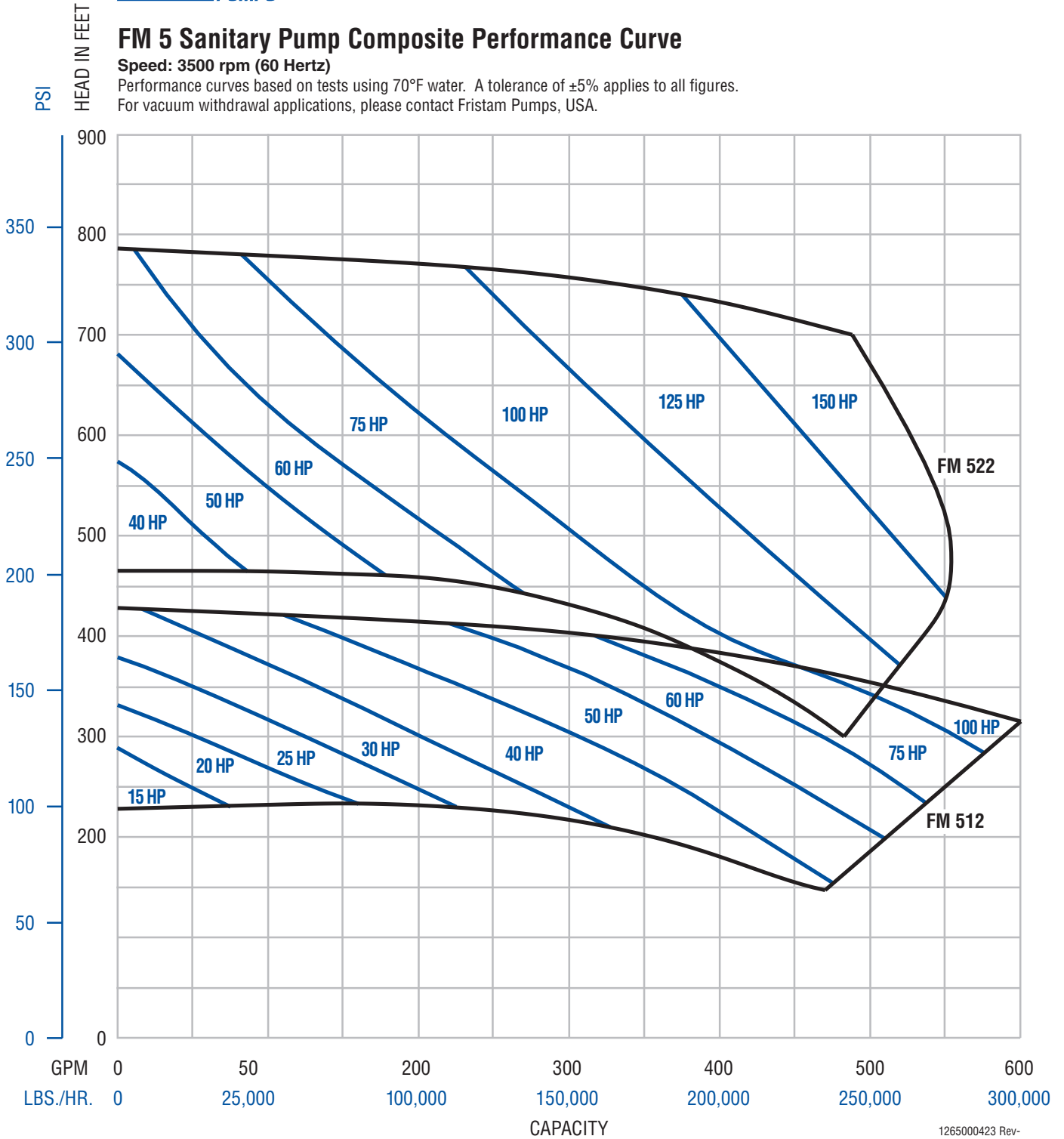

1265000423 Rev-

FPH/FPHP

FPH/FPHP Single-Stage High-Pressure Pumps

Fristam's FPH and FPHP Series sanitary centrifugal high-pressure pumps supplement the operating capability of the Fristam multi-stage product line. Both the FPH and FPHP pumps are modified versions of Fristam's heavy-duty FP Series. These models offer greater flexibility when designing or updating reverse osmosis systems or handling high process line pressures.

The FPHP 722 offers lower flow rates and is often used for pilot plants. The FPH 3542, FPHP 3542 and FPH 3552 are capable of flow rates up to 750 GPM. A close-coupled version of the FPH 3542 is available for applications with space constraints. FPH/FPHP pumps are CIP'able and SIP'able.

Maximum Inlet Pressure Rating

Max. PSI	Models
600	FPH 3542 FPH 3552
1000	FPHP 722 FPHP 3542

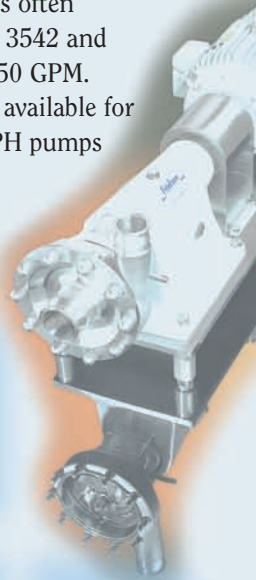

**FPH/FPHP
HIGH-PRESSURE**

FPH/FPHP 722 Dimensional Drawing

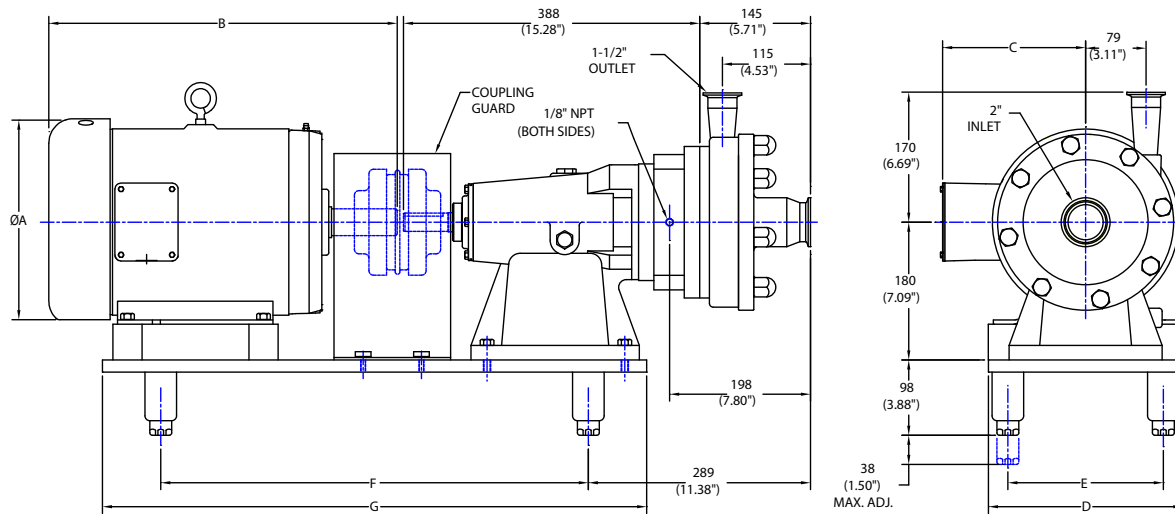

MOTOR HP	NEMA FRAME	ØA	B	C	D	E	F	G
3 HP	182T	216 (8.50)	385 (15.14)	132 (5.21)	279.4 (11.00)	228.6 (9.00)	444.5 (17.50)	596.9 (23.50)
		420 (16.55)	152 (5.97)	279.4 (11.00)	228.6 (9.00)	469.9 (18.50)	622.3 (24.50)	
7.5 HP	213T	263 (10.34)	469 (18.47)	220 (8.67)	279.4 (11.00)	228.6 (9.00)	520.7 (20.50)	673.1 (26.50)
		469 (18.47)	220 (8.67)	279.4 (11.00)	228.6 (9.00)	558.8 (22.00)	711.2 (28.00)	
10 HP	215T		469 (18.47)	220 (8.67)	279.4 (11.00)	228.6 (9.00)	558.8 (22.00)	711.2 (28.00)

1265000457 REV A

NOTE:

ALL DIMENSIONS ARE IN MILLIMETERS (INCHES) UNLESS OTHERWISE SPECIFIED.

MOTOR DIMENSIONS MAY VARY DEPENDING ON MANUFACTURER REQUESTED.

PUMP DIMENSIONS ARE BASED ON CLAMP FITTINGS.

FPH/FPHP 3500 Series Dimensional Drawing

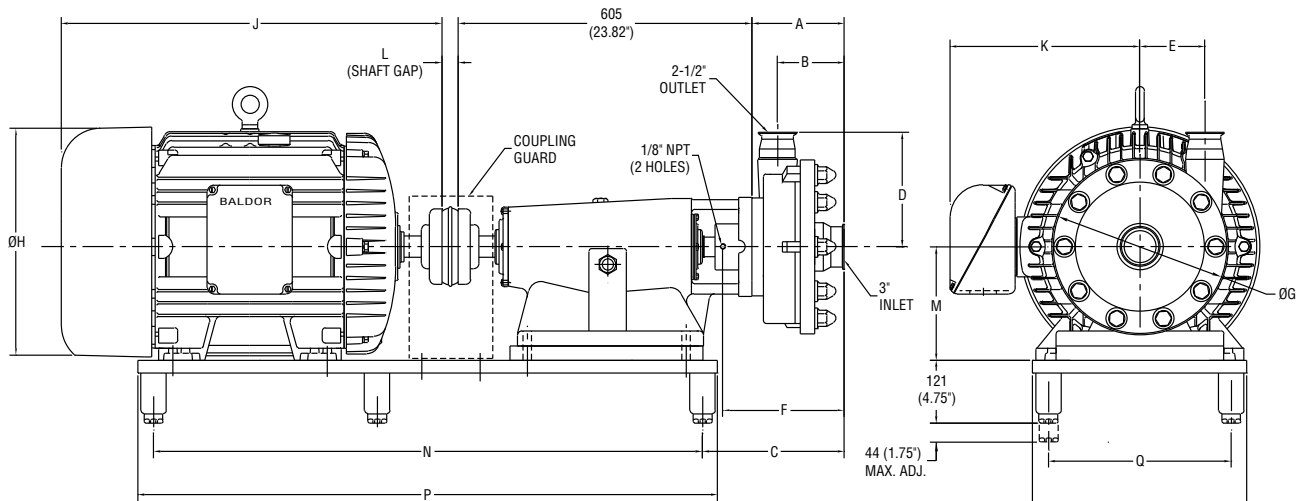

Note: All dimensions are in millimeters (inches) unless otherwise specified.
 Motor dimensions may vary depending on manufacturer requested.
 Pump dimensions are based on clamp fittings.

1265000458 Rev-

Pump Model	A	B	C	D	E	F	G
FPH & FPHP 3542	165 (6.50")	119 (4.68")	263 (10.35")	211 (8.31")	115 (4.53")	224 (8.82")	290 (11.42")
FPH 3552	171 (6.73")	120 (4.72")	266 (10.59")	231 (9.09")	140 (5.51")	230 (9.06")	350 (13.78")

Motor HP	NEMA Frame	H	J	K	L	M	N	P	Q	R
10 HP	215T	263 (10.34")	469 (18.47")	220 (8.67")	16 (.63")	133 (5.25")	1083 (42.62")	1143 (45.00")	321 (12.62")	381 (15.00")
15 HP	254T	270 (10.62")	536 (21.09")	225 (8.86")	6 (.25")	200 (7.87")	1083 (42.62")	1143 (45.00")	321 (12.62")	381 (15.00")
20HP	256T	270 (10.62")	580 (22.84")	225 (8.86")	6 (.25")	200 (7.87")	1083 (42.62")	1143 (45.00")	321 (12.62")	381 (15.00")
25HP	284TS	395 (15.56")	670 (26.39")	333 (13.11")	19 (.75")	200 (7.87")	1083 (42.62")	1143 (45.00")	321 (12.62")	381 (15.00")
30HP	286TS	395 (15.56")	670 (26.39")	333 (13.11")	19 (.75")	200 (7.87")	1083 (42.62")	1143 (45.00")	321 (12.62")	381 (15.00")
40HP	324TS	430 (16.94")	731 (28.78")	371 (14.62")	6 (.25")	203 (8.00")	1083 (42.62")	1143 (45.00")	321 (12.62")	381 (15.00")
50HP	326TS	430 (16.94")	731 (28.78")	371 (14.62")	6 (.25")	203 (8.00")	1083 (42.62")	1143 (45.00")	321 (12.62")	381 (15.00")
60HP	364TS	483 (19.00")	780 (30.72")	380 (14.96")	6 (.25")	229 (9.00")	1108 (43.62")	1168 (46.00")	371 (14.62")	432 (17.00")
75HP	365TS	483 (19.00")	780 (30.72")	380 (14.96")	6 (.25")	229 (9.00")	1108 (43.62")	1168 (46.00")	371 (14.62")	432 (17.00")



FPH/FPHP Sanitary Pump Composite Performance Curve

Speed: 3500 rpm (60 Hertz)

Performance curves based on tests using 70°F water. A tolerance of ±5% applies to all figures. For vacuum withdrawal applications, please contact Fristam Pumps, USA.

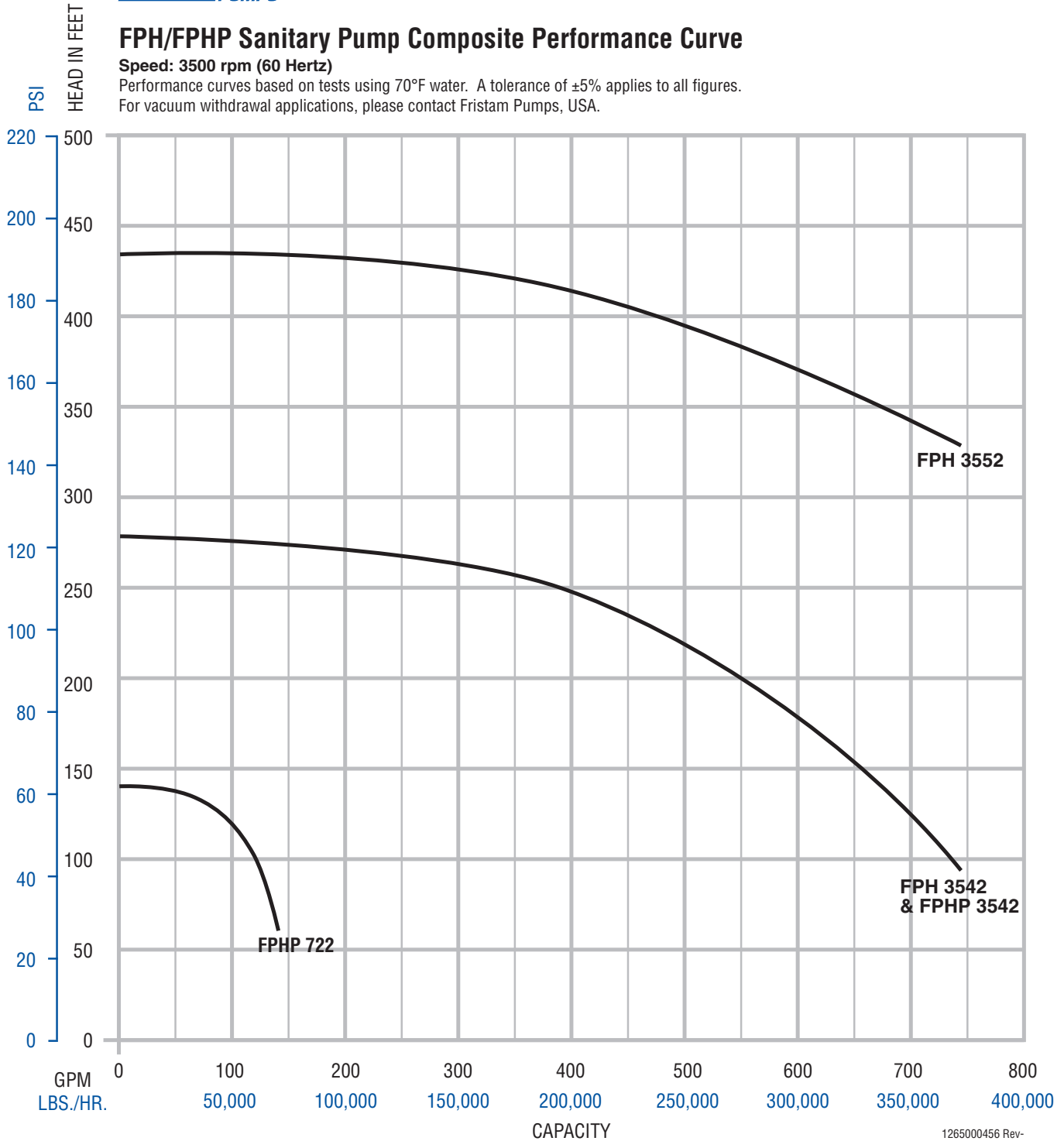

1265000456 Rev-

Worldwide Contact Details

**North America/
South America**
Fristam Pumps USA
P.O. Box 620065
2410 Parview Road
Middleton, WI 53562-2524

TEL: 1-608-831-5001
1-800-841-5001
FAX: 1-608-831-8467

www.fristam.com
fristam@fristampumps.com



Belgium/Luxembourg
Fristam N.V.
Aartselaar

France
Pompes Fristam S.A.
Noisy-le-Sec

Germany
Fristam Pumpen F. StampKG
(GmbH & Co)
Hamburg

Great Britain
Fristam Pumps (UK) Ltd.
Hailsham

India
Fristam Pumps (I) Pvt. Ltd.
Pune

Italy
Fristam Italia S.r.l.
Borgo Ticino (NO)

Japan
Stamp Pumps of Japan Ltd.
Tokyo

Netherlands
Fristam B.V.
De Meern

New Zealand
Fristam Pumps Ltd.
Cambridge

Peoples Republic of China
Fristam Pumps (Shanghai) Co. Ltd.
Shanghai

Poland
Fristam Polska sp.z.o.o.
Warsaw

Russian Federation
Fristam Pumpen R.A.
Moscow

Scandinavia
Fristam Pumper A/S
Saeby

S.E. Asia
Fristam Pumpen A.R.
Singapore

Spain/Portugal
Fristam Iberica S.L.
Barcelona

Fristam's Commitment

Fristam Pumps manufactures the sturdiest products in the industry. Our design reduces repair/replacement cost, downtime and energy consumption, and therefore provides high lifetime value. Fristam is one of the most accessible equipment companies in the world. Fristam's dedication and quality service do not end with your initial purchase. An international network of manufacturing facilities, sales offices and distribution supports Fristam's commitment to customer satisfaction.

3-A, GMP, U.S.D.A., F.D.A., ISO 9001:2000

Fristam complies with and supports regulatory standards. Fristam pumps meet all applicable industry standards for performance, cleanliness and design. As a registered ISO 9001:2000 company, Fristam is committed to consistent quality products.

