

Sanitary Centrifugal Pumps



Fristam Pumps...
Performance You've Come To Expect

Industry Benchmarks: Fristam FP and FPX Series Pumps

Fristam is an international manufacturer of sanitary centrifugal and positive displacement pumps respected for performance, reliability and technical superiority. The FP and FPX Series serve as industry benchmarks for quiet, efficient, low maintenance operations.

FP and FPX: Different Series for Different Needs

The FP Series is the original Fristam pump which established the standards for high performance centrifugals. The success of the FP led satisfied customers to request a Fristam pump for less severe applications. The result was the FPX, a pump combining the same pump head with a modified mounting flange and shaft. Since its introduction, the FPX has become an industry standard for most general applications.

Whether it's FP or FPX, both series offer the perfect combination of the following outstanding features and benefits.

An Alternative to Positive Pumps

For applications with shear sensitive products and those having viscosities lower than 1200 cps, Fristam centrifugal pumps have replaced positive displacement pumps. Close internal tolerances and superior impeller design allow Fristam centrifugals to successfully pump cream, eggs and cell cultures.

Low Maintenance

Fristam's reputation is built on proven performance, reliability and minimal downtime. Contributing to our reputation are heavy cast construction, superior seal design, heavy shafts, close tolerances and an ability to withstand hydraulic shock and cavitation.

Low NPSH (Net Positive Suction Head) Requirements

Insufficient NPSH* is the cause of the majority of pump process problems. Close internal tolerances, advanced impeller design and the availability of volute and non-volute housings allow Fristam pumps to perform with the lowest NPSH requirements of any standard pump. Due to low NPSH requirements, evaporator manufacturers and others with vacuum applications have turned to Fristam as the industry leader for years.

* NPSH = The absolute pressure at the suction nozzle necessary for the pump to operate properly.

Less Noise

Close tolerances, heavy-duty construction and dynamically balanced impellers contribute to building Fristam's reputation for quiet performance.

High Efficiency

As the originator of the high efficiency sanitary centrifugal, Fristam continues to set the standard. The industry's broadest range of pump head and impeller combinations allows you to better match pumps to specific duties for optimum efficiency.



Long Seal Life

Seal life is critical to pump performance. Fristam's unique internal seal uses the cooling and lubrication of the product to provide longer seal life. The Fristam design also maintains constant pressure between the faces to prevent potential contamination. Even under extreme conditions, Fristam's seal life is often measured in decades.



Fristam's Standard Internal Mechanical Seal

A single seal is available on the FP and FPX Series pumps. A double seal is standard on the FP pump only.

Material Options:

- Chrome Oxide/Carbon - Standard
- Silicon Carbide/Carbon
- Silicon Carbide/Silicon Carbide
- Chrome Oxide/Silicon Carbide

Fristam's External Seal

In addition to our single and double internal mechanical seals, our customers have the option of an external seal. Our external seal offers various benefits to the customer.

- Balanced external design
- Replaceable wear surfaces
- Easy assembly without tension adjustments
- Silicon Carbide/Carbon seal face material

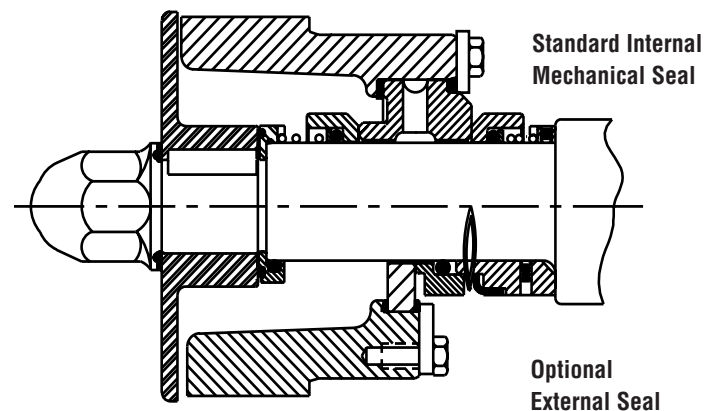

Worldwide commitment to customer satisfaction

Fristam is represented worldwide through an international sales and service network. Fristam has been manufacturing pumps in the United States since 1983.

Heavy-Duty FP Series

FP Series



The FP Series handles the most demanding applications such as evaporators, withdrawal from vacuum vessels, aseptic processing and any process involving high viscosity, high temperature, abrasive products or where double seals are needed. The ability to handle the tough applications results from the FP's use of a heavy pedestal support between the C-face motor and the pump housing. The pedestal accommodates numerous seal options, reduces noise and vibration and helps dissipate heat.

A complete line of options is available on the FP ranging from special gasketing and piping to bearing block mounting.

Performance Parameters

- Product viscosity up to 800 cps
- Process temperature up to 400°F
- Maximum inlet pressure 150 PSI
- Products being withdrawn from a vacuum
- Abrasive products
- Single or double seal available
- Seal flush
- Internal seal product flush
- Flange support (pedestal) is standard, bearing block style support also available
- All wetted metal components are 316L stainless steel, standard
- John Crane seals available
- Capable of pumping up to 900 gallons per minute

Specialty Applications

- Vacuum Withdrawal
- Aseptic Processing
- Abrasive Products

Standard-Duty FPX Series

The FPX Series is the most popular Fristam pump and a value leader for standard duties. This series is designed with the pump head mounted on a C-face motor via a sturdy flange. The FPX is available with a single seal only. It is offered with a water cascade for more difficult applications.

The competitive price makes the FPX the pump of choice for CIP supply and return, product transfer, receiving and load-out, pumping to fillers, separators, filters, heat exchangers and a wide variety of other equipment.

Performance Parameters

- Product viscosity up to 600 cps
- Process temperature up to 400°F
- Maximum inlet pressure 150 PSI
- Single seal only
- Internal seal product flush
- Water cascade available
- Mounted to C-face motor
- All wetted metal components are 316L stainless steel, standard
- Capable of pumping up to 900 gallons per minute

Applications For FP and FPX

- Bottling
- Cleaning Applications/CIP
- De-alcoholization
- Distillation
- Emulsifying
- Water for Injection



Components at a Glance

FP
SINGLE FLANGE

Heavy Cast Pedestal
Reduces noise and vibration and helps dissipate heat.

Shaft Clamp Design
For simple, accurate mounting.

Spring Assembly
Loads seal accurately.

Internal Seals
Single or double seal available.

Volute or Non-Volute Housings
Designed to match your specific applications.

FPX

SINGLE FLANGE

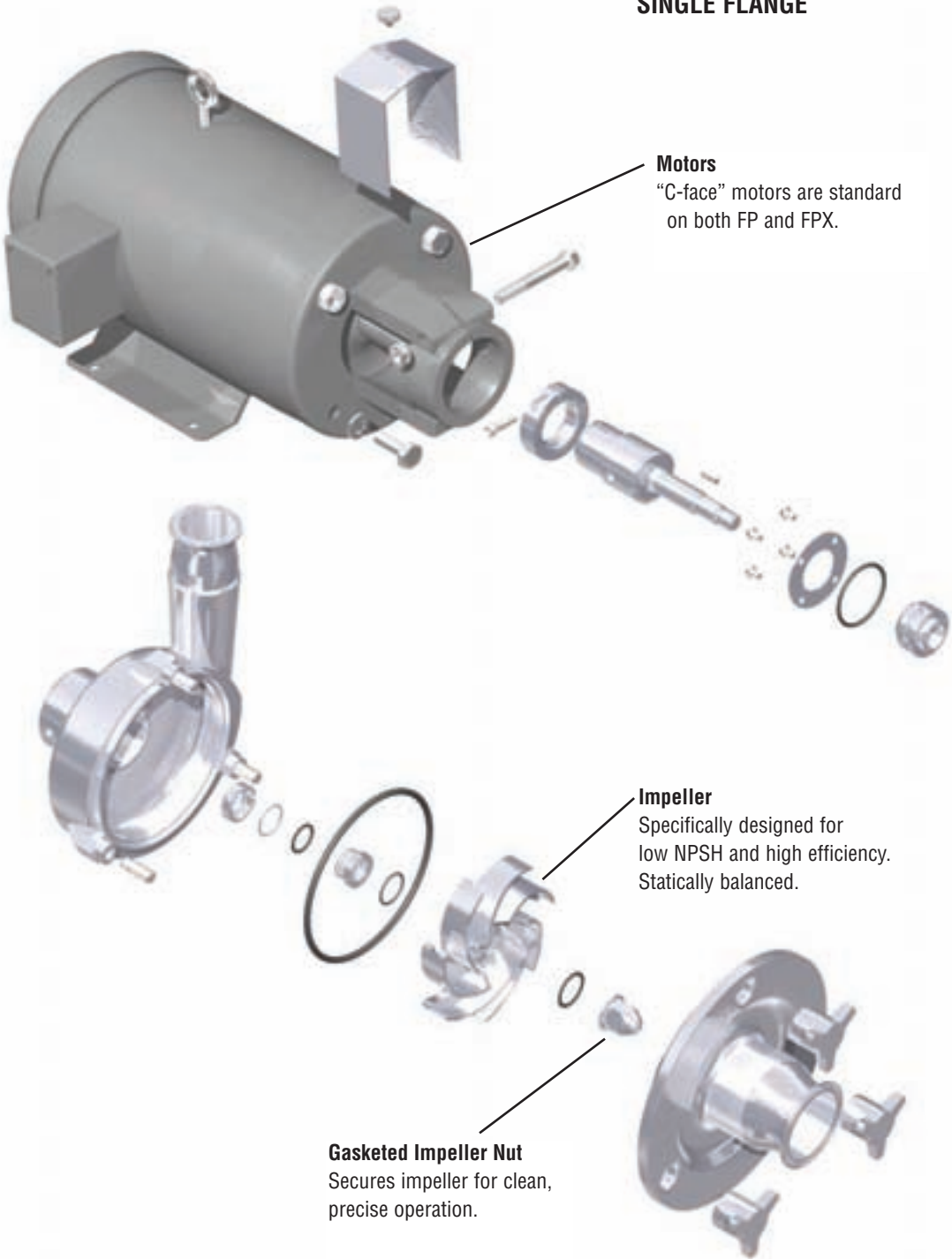

Motors
"C-face" motors are standard on both FP and FPX.

Impeller
Specifically designed for low NPSH and high efficiency. Statically balanced.

Gasketed Impeller Nut
Secures impeller for clean, precise operation.

1750 RPM Composite* Performance Curve

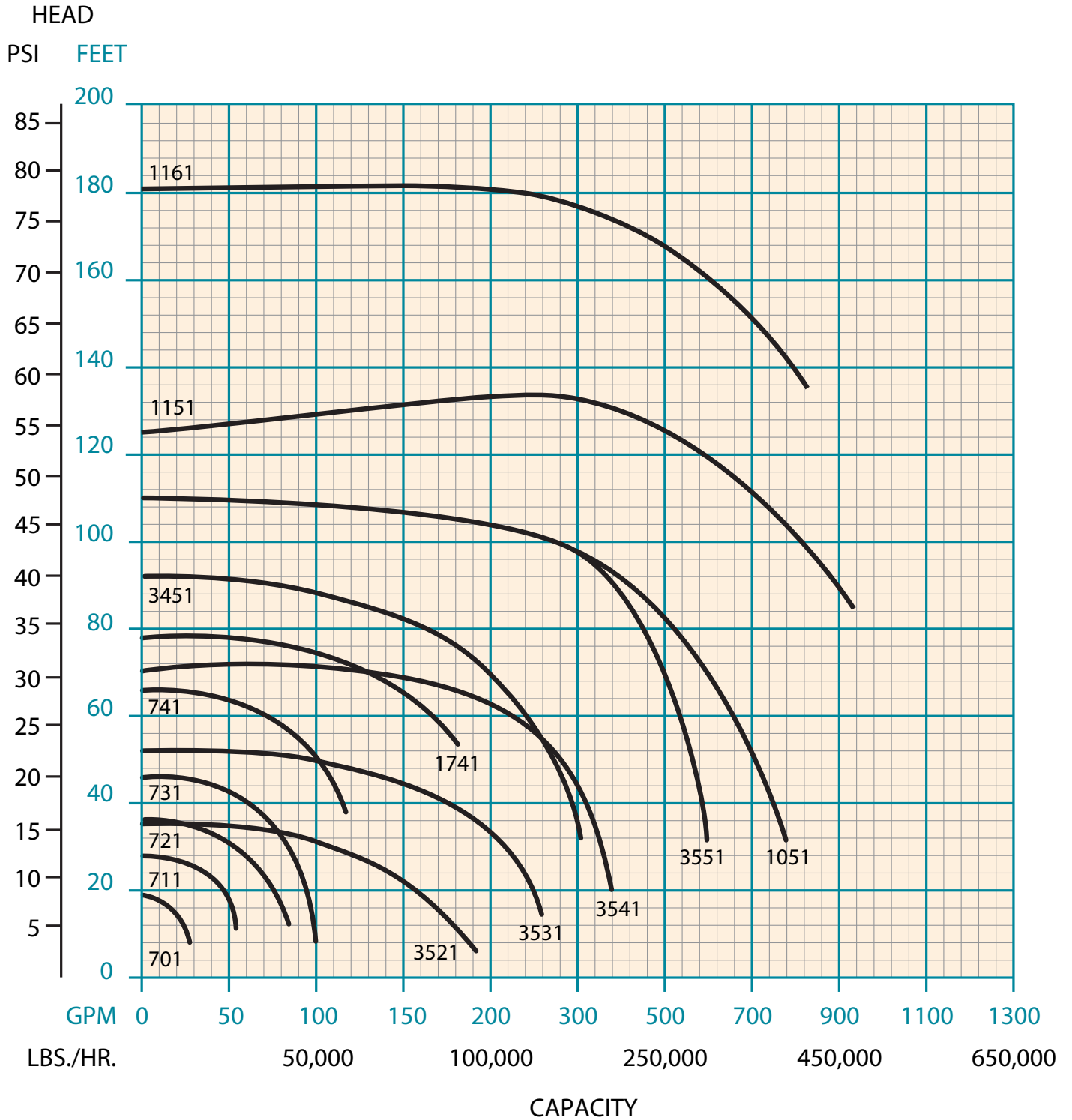

*See the Fristam FP/FPX Curve book or visit www.fristam.com for individual pump performance curves.

3500 RPM Composite* Performance Curve

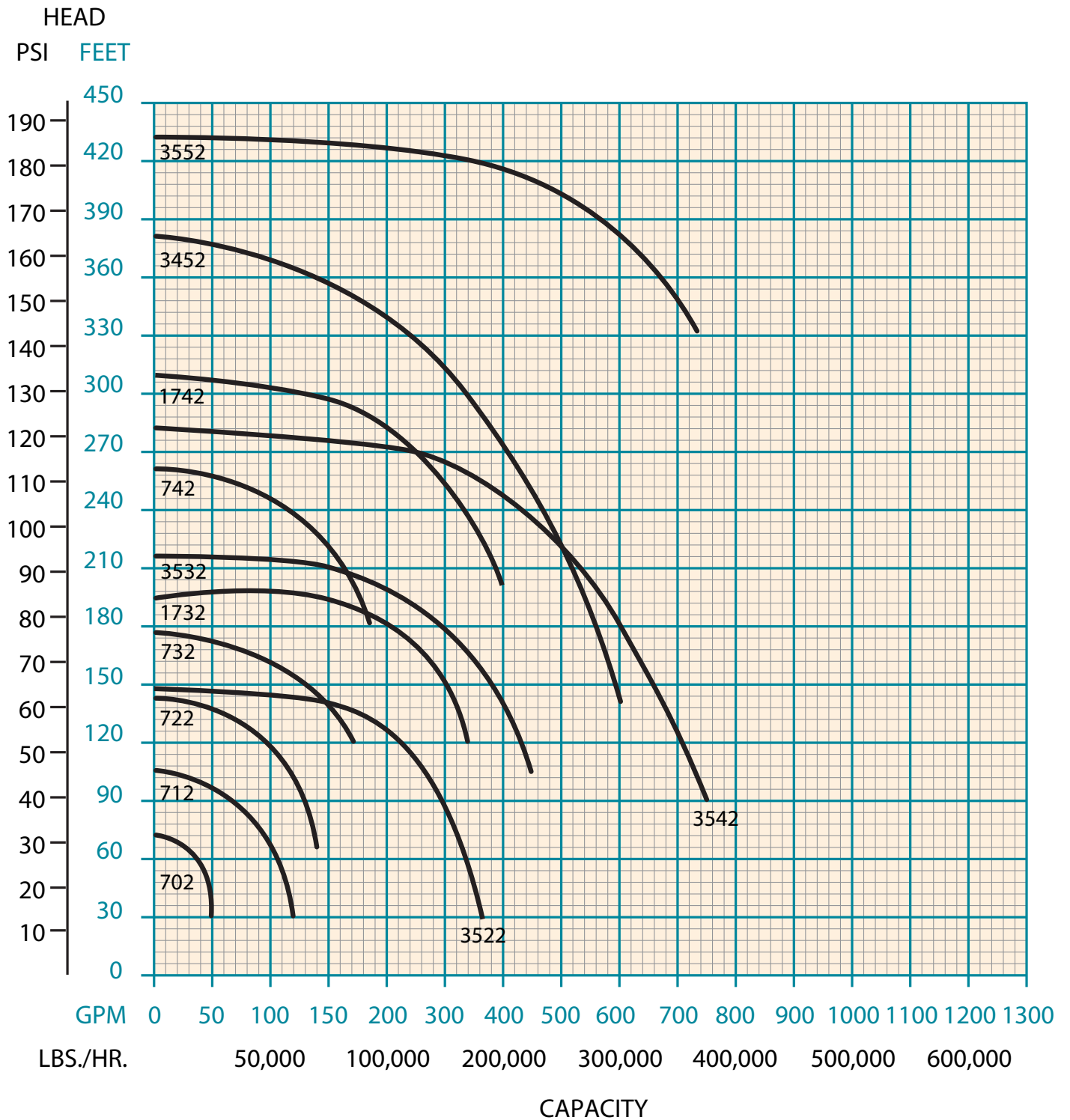

*See the Fristam FP/FPX Curve book or visit www.fristam.com for individual pump performance curves.

Options



Fittings

Fristam pumps can be supplied with most types of sanitary or industrial fittings. Some alternate inlet sizes are also available. Sanitary fittings must be used on pumps that are required to meet 3-A standards.

Motor Options

Standard motors provided are “Inverter Ready”, TEFC with a locked front bearing. The following options are available:

- Washdown
- Premium Efficiency
- Explosion-Proof
- IEC
- Chemical Duty

Surface Finish

Standard surface finish is 32 Ra. Finer finishes up to 15 Ra and electropolished are available.

Tungsten Carbide Coatings

For extremely abrasive products, internal components can be coated with tungsten carbide to prevent erosion.



Bearing Blocks

Fristam pumps are available with a bearing block style mounting which can accommodate motors up to 100 HP. The base plate is stainless steel.



Adjustable Base

Fristam Pumps’ adjustable bases use solid stainless steel components with adjustable legs.

Stainless Steel Motors/Adapters

Pumps can be provided with stainless steel motors and adapters for protection against corrosive environments and a clean appearance.

Portable Cart

Most Fristam pumps can be mounted on a stainless steel cart, depending on motor size.



Specialty Pumps



Water for Injection

The Fristam WFI pump is a precision adaptation of our famous heavy-duty FP Series pump. Fristam pioneered the “Double Safe Seal System” to ensure product sterility. Our low pressure, low flush design protects product sterility and saves valuable product.



Aseptic Centrifugal

Aseptic processing requires equipment which assures both product dependability and sterility. The Fristam FP double-seal pump offers a perfect fit for aseptic processing. With sterile barriers at all seal points, including the cover gasket, your product is protected from contamination.



Jacketed Pump Housing

Fristam’s jacketed pump housing is compatible with most FP and FPX models. The jacketed pump housing is designed for products that require temperature control. This includes applications that require solids to stay in solution, such as chocolate, or for applications that require a cold product, such as brewing.



The Fisa Award

Fristam is proud to be a three-time Fisa award winner. This award is based on the manufacturer’s contributions in the areas of commitment to distributors, quality of support, competitiveness and innovation.

Worldwide Contact Details

North America/ South America

Fristam Pumps USA
P.O. Box 620065
2410 Parview Road
Middleton, WI 53562-2524

TEL: 1-608-831-5001
1-800-841-5001
FAX: 1-608-831-8467

www.fristam.com
fristam@fristampumps.com



Belgium/Luxembourg
Fristam N.V.
Aartselaar

France
Pompes Fristam S.A.
Noisy-le-Sec

Germany
Fristam Pumpen F. StampKG
(GmbH & Co)
Hamburg

Great Britain
Fristam Pumps (UK) Ltd.
Hailsham

India
Fristam Pumps (I) Pvt. Ltd.
Pune

Italy
Fristam Italia S.r.l.
Borgo Ticino (NO)

Japan
Stamp Pumps of Japan Ltd.
Tokyo

Netherlands
Fristam B.V.
De Meern

New Zealand
Fristam Pumps Ltd.
Cambridge

Peoples Republic of China
Fristam Pumps (Shanghai) Co. Ltd.
Shanghai

Poland
Fristam Polska sp.z.o.o.
Warsaw

Russian Federation
Fristam Pumpen R.A.
Moscow

Scandinavia
Fristam Pumper A/S
Saeby

S.E. Asia
Fristam Pumpen A.R.
Singapore

Spain/Portugal
Fristam Iberica S.L.
Barcelona

Fristam's Commitment

Fristam Pumps manufactures the sturdiest products in the industry. Our design reduces repair/replacement cost, downtime and energy consumption, and therefore yields high lifetime value. Fristam is one of the most accessible equipment companies in the world. Fristam's dedication and quality service do not end with your initial purchase. An international network of manufacturing facilities, sales offices and distribution supports Fristam's commitment to customer satisfaction.

3-A, GMP, U.S.D.A., F.D.A., ISO and EHEDG

Fristam complies with and supports regulatory standards. FL II Series pumps meet all applicable industry standards for performance, cleanliness and design. As a registered ISO 9001:2000 company, Fristam is committed to consistent quality products.



Visit www.fristam.com for
a current list of literature

Fristam
PUMPS

Re-order #1050000102 R5
©2007 Fristam Pumps USA